

I B. Tech II Semester Regular Examinations, April/May - 2017
ENGINEERING DRAWING
 (Com. to CE, EEE, BIO)

Time: 3 hours

Max. Marks: 70

- Note: 1. Question Paper consists of two parts (**Part-A** and **Part-B**)
 2. Answering the question in **Part-A** is Compulsory
 3. Answer any **FOUR** Questions from **Part-B**
- ~~~~~

PART -A

1. a) Draw an equilateral triangle of 75mm side and inscribe a circle in it. Draw the projections of the figure, when its plane is vertical and inclined at 30° to the VP and one of the sides of the triangle is inclined at 45° to the HP. (7M)
- b) Draw the Isometric View: (7M)

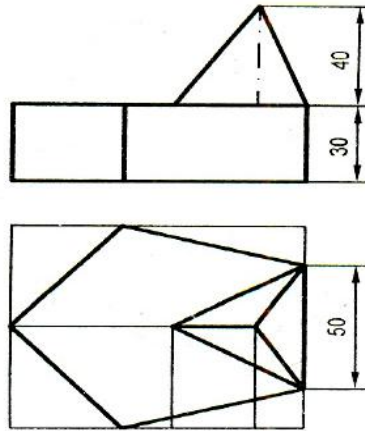

PART -B

2. a) Construct a diagonal scale of RF=1/32 showing yards, feet and inches and to measure up to 4 yards. (7M)
- b) Construct an ellipse when the distance of the focus from the directrix is equal to 80 mm (7M) and eccentricity is $3/5$.



3. a) A point A is situated in the first quadrant. Its shortest distance from the intersection point of HP and VP and auxiliary plane is 60 mm and it is equidistant from the principal planes. Draw the projections of the point and determine its distance from the principal planes. (7M)
- b) Draw the projections of a 75 mm long straight line in the following positions: (7M)
- Parallel to the both HP & VP and 25mm from each
 - Perpendicular to the HP and 20 mm in front of the VP and its one end 15 mm above the HP
 - Inclined at 45° to the VP, in the HP and its one end in the VP.
4. Draw the projections of a line AB, 90 mm long, its midpoint M being 50 mm above the HP and 40 mm in front of the VP. The end A is 20 mm above the HP and 10 mm in front of the VP. Show the traces and inclinations of the line with the HP and VP. (14M)
5. Draw the projections of a circle of 75 mm diameter having the end A of the diameter AB in the horizontal plane, the end B in the vertical plane, and the surface inclined at 30° to HP and at 60° to the VP. (14M)
6. Draw the projections of a cone, base 75 mm diameter and axis 100 mm long, lying on the ground on one of its generators with the axis parallel to the VP. Assuming the cone to be resting on its base on the ground. Draw its projections. (14M)
7. Draw (i) Front View (ii) Top View (iii) Side View (14M)

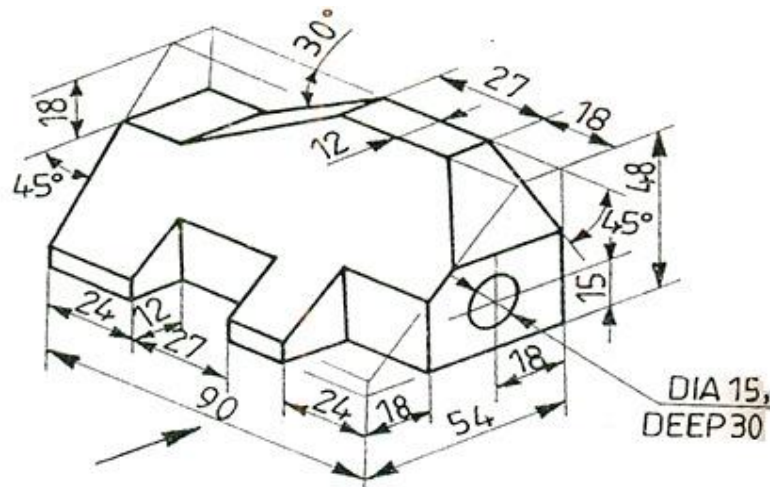

I B. Tech II Semester Regular Examinations, April/May - 2017
ENGINEERING DRAWING
 (Com. to CE, EEE, BIO)

Time: 3 hours

Max. Marks: 70

- Note: 1. Question Paper consists of two parts (**Part-A** and **Part-B**)
 2. Answering the question in **Part-A** is Compulsory
 3. Answer any **FOUR** Questions from **Part-B**

PART -A

1. a) Draw the projections of a regular pentagon of 40 mm side, having its surface inclined at 30° to the HP and a side parallel to the HP and inclined at an angle of 60° to the VP. (7M)
- b) Draw (i) Front View (ii) Top View (iii) Side View (7M)

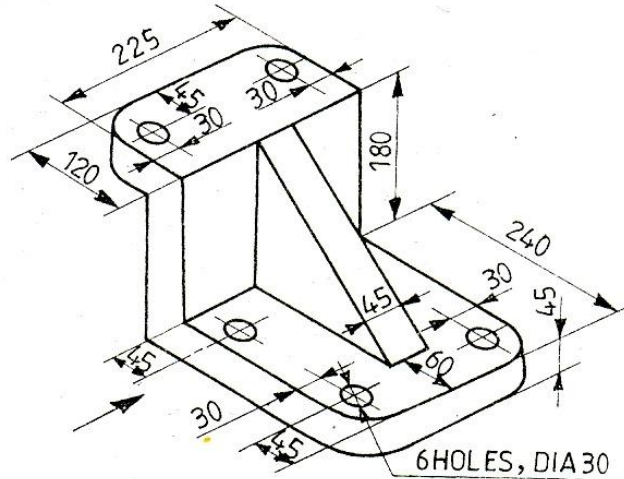

PART -B

2. a) The major axis of an ellipse is 100 mm long and the foci are at a distance of 15 mm from its ends. Find the minor axis. Draw the ellipse by Oblong method. (7M)
- b) Draw a vernier scale of RF=1/25 to read centimetres up to 4 m and on it, show lengths representing 2.39 m and 0.91 m. (7M)
3. a) A point P is 20 mm below HP and lies in the third quadrant. Its shortest distance from xy is 40 mm. Draw its projections. (7M)
- b) The length of the top view of a line parallel to the VP and inclined at 45° to the HP is 5 cm. One end of the line is 1.2 cm above the HP and 2.5 cm in front of the VP. Draw the projections of the line and determine its true length. (7M)



4. The front view of a line makes an angle of 30° with xy . The HT of the line is 45 mm in front of the VP while its VT is 30 mm below the HP. One end of the line is 10 mm above the HP and the other end 100 mm in front of the VP. Draw the projections of the line and determine its true length and its inclinations with the HP and VP. (14M)
5. A thin circular plate of 70 mm diameter is resting on its circumference such that its plane is inclined 60° to the HP and 30° to the VP. Draw the projections of the plate. (14M)
6. Draw the projections of a cylinder 75 mm diameter and 100 mm long, lying on the ground with its axis inclined at 30° to the VP and parallel to the ground. (14M)
7. Draw the Isometric view: (14M)

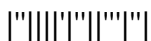
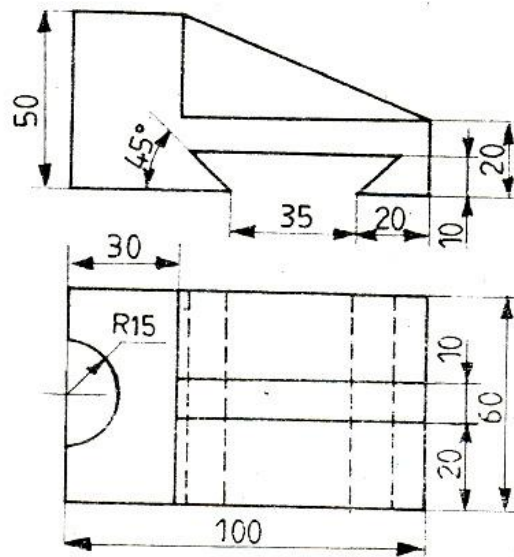

I B. Tech II Semester Regular Examinations, April/May - 2017
ENGINEERING DRAWING
 (Com. to CE, EEE, BIO)

Time: 3 hours

Max. Marks: 70

- Note: 1. Question Paper consists of two parts (**Part-A** and **Part-B**)
 2. Answering the question in **Part-A** is Compulsory
 3. Answer any **FOUR** Questions from **Part-B**
- ~~~~~

PART -A

1. a) A composite plate of negligible thickness is made up of a rectangle 60 mm × 40 mm, and a semi-circle on its longer side. Draw its projections when the longer side is parallel to the HP and inclined at 45° to the VP, the surface of the plate making 30° angle with the HP. (7M)
- b) Draw the Isometric View (7M)

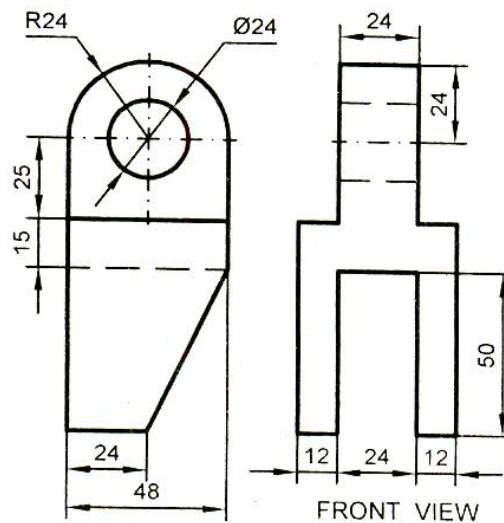

PART -B

2. a) The foci of an ellipse 90 mm apart and the minor axis is 65 mm long. Determine the length of major axis and draw the ellipse by oblong method. Draw a curve parallel to the ellipse and 25 mm away from it. (10M)
- b) Construct a regular hexagon of 40 mm side. (4M)



3. a) A point 30 mm above xy line is the top view of two points P and Q. The front view of P is 45 mm above the HP while that of the point Q is 35 mm below the HP. Draw the projections of the points and state their positions with reference to the principal planes and their quadrants in which they lie. (7M)
- b) A vertical line AB 75 mm long has its end A in the HP and 25 mm in front of the VP. A line AC 100 mm long, it is in the HP and parallel to the VP. Draw the projections of the line joining B and C, and determine its inclinations with the HP. (7M)
4. Two oranges on a tree are respectively 1.8 m and 3 m above the ground, and 1.2 m and 2.1 m from a 0.3 m thick wall, but on the opposite side of it. The distance between the oranges, measure along the ground and parallel to the wall is 2.7 m. Determine the real distance between the oranges. (14M)
5. A 60° set square of 125 mm longest side is so kept that the longest side is in the HP making an angle of 30° with the VP and the set square itself inclined at 45° to the HP. Draw the projections of the set square. (14M)
6. Draw the projections of a pentagonal prism, base 25 mm side and axis 50 mm long, resting on one of its rectangular faces on the ground, with the axis inclined at 45° to the VP. (14M)
7. Draw (i) Front View (ii) Top View (iii) Side View (14M)

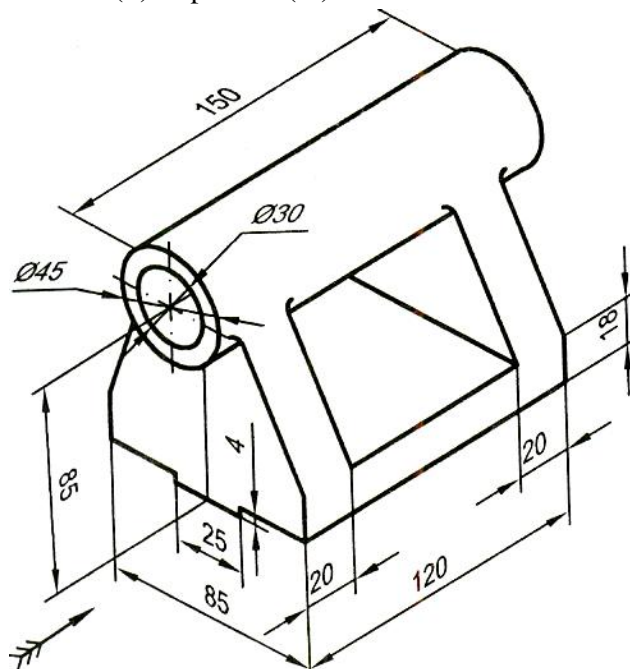

I B. Tech II Semester Regular Examinations, April/May - 2017
ENGINEERING DRAWING
 (Com. to CE, EEE, BIO)

Time: 3 hours

Max. Marks: 70

- Note: 1. Question Paper consists of two parts (**Part-A** and **Part-B**)
 2. Answering the question in **Part-A** is Compulsory
 3. Answer any **FOUR** Questions from **Part-B**

PART -A

1. a) A semi-circular plate of 80 mm diameter has its straight edge in the VP and inclined at 45° to the HP. The surface of the plate makes an angle of 30° with the VP. Draw its projections. (7M)
 b) Draw (i) Front View (ii) Top View (iii) Side View (7M)

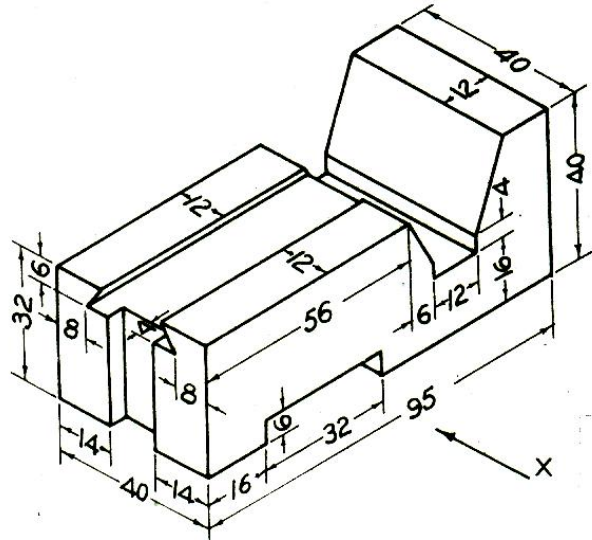

PART -B

2. a) Draw a vernier scale of R.F. = 5 to read $1/5$ cm and $1/25$ cm and to measure upto 5 cm. Mark on a scale distances of 2.12 cm and 4.29 cm. (7M)
 b) The major axis of an ellipse is 150 mm long and the minor axis 100 mm long. Find the foci and draw the ellipse by arcs of circles method. Draw a tangent to the ellipse at a point on it 25 mm above the major axis. (7M)
3. a) A 100 mm long line is parallel to and 40 mm above the HP. Its two ends are 25 mm and 50 mm in front of the VP respectively. Draw its projections and find its inclinations with the VP. (7M)
 b) A point P is 15 mm above the HP and 20 mm in front of the VP. Another point Q is 25 mm behind the VP and 40 mm below the HP. Draw the projections of P and Q keeping the distance between their projectors equal to 90 mm. Draw straight lines joining their top views and their front views. (7M)



4. The projectors drawn from the HT and VT of a straight line AB are 80 mm apart (14M) while those drawn from its ends are 50 mm apart. The HT is 35 mm in front of the VP, the VT is 55 mm above the HP and the end A is 10 mm above the HP. Draw the projections of AB and determine its length and inclinations with the reference planes.
5. Draw a regular hexagon of 40 mm side, with its two sides vertical. Draw a circle of 40 mm diameter in its centre. The figure represents a hexagonal plate with a hole in it and having its surface parallel to the VP. Draw its projections when the surface is vertical and inclined at 30° to the VP. Assume the thickness of the plate to be equal to that of a line. (14M)
6. A hexagonal pyramid, base 25 mm side and axis 50 mm long, has an edge of its base on the ground. Its axis is inclined at 30° to the ground and parallel to the VP. Draw its projections. (14M)
7. Draw the Isometric view: (14M)

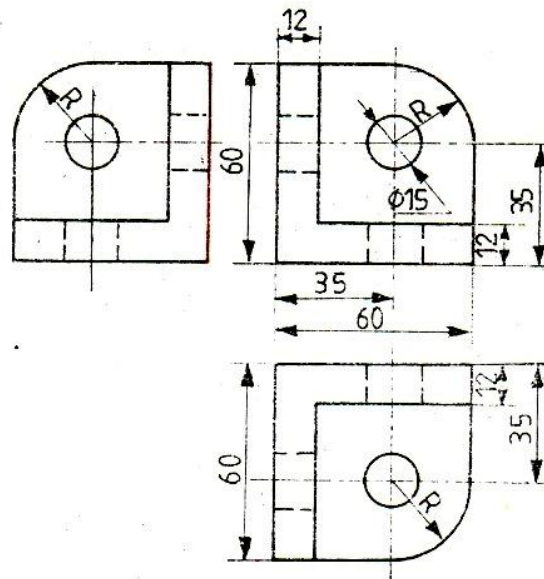

I B. Tech II Semester Regular Examinations, April/May - 2017
ENGINEERING PHYSICS
 (Com. to CE, ME, CHEM, AE, BIO, AME, MM, PE, PCE, MET)

Time: 3 hours

Max. Marks: 70

Note: 1. Question Paper consists of two parts (**Part-A** and **Part-B**)
 2. Answering the question in **Part-A** is Compulsory
 3. Answer any **FOUR** Questions from **Part-B**

~~~~~

**PART -A**

1. a) Why two different light sources can't act as coherent sources? (2M)
- b) Why diffraction of light is not evident in daily life? (2M)
- c) Define O-ray and E-ray. (2M)
- d) How is laser different from an ordinary light? (2M)
- e) What is reverberation time? (2M)
- f) Draw (110) & (211) planes in a cubic crystal. (2M)
- g) Why magnetic susceptibility of dia magnetic materials is negative? (2M)

**PART -B**

2. a) Explain the formation of Newton's rings and derive the expression for diameter of the dark rings in the reflected light. Also show that rings are not equally spaced. (10M)
- b) In a Newton's rings experiment, the diameters of 5<sup>th</sup> and 15<sup>th</sup> dark rings are 0.336cm and 0.59cm respectively. If the radius of curvature of plano-convex lens is 100cm, find the wavelength of monochromatic light. What happens to ring diameters if air film is replaced with liquid of refractive index 1.33. (4M)
3. a) What is plane diffraction grating? Obtain an equation to find the wavelength of light using plane diffraction grating. What are the advantages of increasing number of lines in a grating? (10M)
- b) Write the differences between interference and diffraction. (4M)
4. a) Explain the principle, construction and working of Nicol prism. Describe how it can be used as polarizer. (7M)
- b) Write the differences between spontaneous and stimulated emissions? What is the necessity of population inversion in achieving lasing action? (7M)
5. a) What are ultrasonics? Explain a method with a neat diagram to produce ultrasonics. (10M)
- b) Explain the basic requirements of acoustically a good hall. (4M)
6. a) What are Miller indices? How they are obtained? What is their importance? (7M)
- b) What is Nuclear fission? Explain about the chain reactions. (7M)
7. a) What are ferromagnetic materials? Discuss their properties and applications. (6M)
- b) Calculate the expression for internal field of a dielectric material. (8M)



**I B. Tech II Semester Regular Examinations, April/May - 2017**  
**ENGINEERING PHYSICS**

(Com. to CE, ME, CHEM, AE, BIO, AME, MM, PE, PCE, MET)

Time: 3 hours

Max. Marks: 70

Note: 1. Question Paper consists of two parts (**Part-A** and **Part-B**)  
 2. Answering the question in **Part-A** is Compulsory  
 3. Answer any **FOUR** Questions from **Part-B**

~~~~~

PART -A

1. a) Write any two applications of Newton's rings. (2M)
- b) Write any two differences between interference and diffraction. (2M)
- c) What is the difference between unpolarized and polarized light? (2M)
- d) What is the role of a metastable state in lasers? (2M)
- e) Write any two applications of ultrasonics. (2M)
- f) Silver has FCC structure and iron has BCC structure. Identify which one has primitive unit cell. (2M)
- g) Define dielectric loss and dielectric strength. (2M)

PART -B

2. a) Why circular fringes are observed in Newton's rings? Explain the procedure for determination of wavelength of a monochromatic light using Newton's rings experiment. Which method (Newton's rings or Interferometer) is better to find the wavelength of monochromatic light? Why? (10M)
- b) Describe the method to determine refractive index of a material using Newton's rings. (4M)
3. a) Explain the Fraunhofer diffraction due to single slit. Obtain the conditions for maxima and minima. (10M)
- b) In the diffraction grating, what is effect of total number of lines and width of grating on the spectrum. (4M)
4. a) With a neat diagram, explain the construction and working of He-Ne laser. (10M)
- b) Explain any two methods to produce plane polarized light. (4M)
5. a) Explain in detail the Non destructive testing (NDT) using ultrasonics. (4M)
- b) Derive Sabine's formula for reverberation time. (10M)
6. a) Derive the relation between interplanar distance and Miller indices of the planes of a cubic crystal. (10M)
- b) Silver has FCC structure and its atomic radius is 1.441\AA . Find the spacing of (220) planes. (4M)
7. a) Classify the magnetic materials in atomic point of view. (4M)
- b) What is dielectric breakdown? Explain different kinds of dielectric breakdown mechanisms. (10M)



I B. Tech II Semester Regular Examinations, April/May - 2017
ENGINEERING PHYSICS
 (Com. to CE, ME, CHEM, AE, BIO, AME, MM, PE, PCE, MET)

Time: 3 hours

Max. Marks: 70

Note: 1. Question Paper consists of two parts (**Part-A** and **Part-B**)
 2. Answering the question in **Part-A** is Compulsory
 3. Answer any **FOUR** Questions from **Part-B**

~~~~~

**PART -A**

1. a) Write the principle of Superposition. (2M)
- b) In a Newton's rings experiment, why we choose a plano convex lens of larger radius of curvature? (2M)
- c) Define Mass defect and binding energy. (2M)
- d) What is a quarter wave plate? (2M)
- e) What is meant by non-destructive testing? (2M)
- f) Define the terms primitive and non-primitive unit cells. (2M)
- g) What are ferroelectrics? (2M)

**PART -B**

2. a) Why the Newton's rings are circular and central fringe is dark? Show that fringes are unequally spaced. Explain the determination of wavelength of monochromatic light using Newton's rings experiment. (10M)
- b) In Michelson's interferometer 200 fringes crossed the field of view when the movable mirror is displaced through a distance of 0.0589mm. Find the wavelength of light used. (4M)
3. a) Explain the Fraunhofer's diffraction due to a double slit. Explain the intensity distribution curve. (10M)
- b) Write the differences between Fresnel's and Fraunhofer's diffractions. (4M)
4. a) Explain the construction and working of a polarimeter. (7M)
- b) Describe the construction and working of Ruby laser with a neat energy level diagram. (7M)
5. a) Write notes on absorption coefficient of a material and its measurement. (7M)
- b) Explain the production of ultrasonics by any one method. (7M)
6. a) What are Miller indices? Explain their role in the crystal structures. Draw the crystal planes having Miller indices (100), (111), (211). (10M)
- b) Write about controlled and uncontrolled chain reactions. (4M)
7. a) Explain the hysteresis of ferromagnetic materials. How it can be used to select materials for construction of permanent magnets? (9M)
- b) What are ferroelectric materials? How they are different from dielectric materials? (5M)



**I B. Tech II Semester Regular Examinations, April/May - 2017**  
**ENGINEERING PHYSICS**  
 (Com. to CE, ME, CHEM, AE, BIO, AME, MM, PE, PCE, MET)

Time: 3 hours

Max. Marks: 70

Note: 1. Question Paper consists of two parts (**Part-A** and **Part-B**)  
 2. Answering the question in **Part-A** is Compulsory  
 3. Answer any **FOUR** Questions from **Part-B**

**PART -A**

1. a) Why the central fringe is dark in Newton's rings experiment? (2M)
- b) What is diffraction grating? (2M)
- c) What is difference between Polarimeter and Saccharimeter? (2M)
- d) Write any two industrial applications of ultrasonics. (2M)
- e) Lead is face centered cubic with atomic radius of  $1.746\text{\AA}$ . Calculate the interplanar spacing of (200) plane. (2M)
- f) Explain the Hysteresis of Ferro magnetic materials. (2M)
- g) Define dielectric constant and dielectric loss. (2M)

**PART -B**

2. a) What is thin film? Derive the expressions for maxima and minima for reflected light in case of transparent film of uniform thickness. (10M)
- b) What will happen if the plano convex lens in the Newton's rings experiment is lifted up by  $\lambda/2$ , where  $\lambda$  is wavelength of monochromatic light used? (4M)
3. a) What is resolving power of a grating? Obtain an expression for resolving power of a diffraction grating and prove that it is independent of grating element. (10M)
- b) Calculate the maximum order of diffraction possible with a plane transmission grating having 15000 lines/inch and light of wavelength  $6000\text{\AA}$ . (4M)
4. a) Explain the principle, construction and working of Nicol prism. (6M)
- b) Explain construction and working of He-Ne laser with a neat energy level diagram. (8M)
5. a) State and explain the acoustic requirements of a concert hall. (4M)
- b) Explain the production of ultrasonics by Magnetostriction method. Write its merits and demerits. (10M)
6. a) State and derive Bragg's law. Calculate the longest wavelength that can be analyzed by rock salt crystal of spacing  $2.82\text{\AA}$  in the first order. (10M)
- b) Distinguish between fission and fusion reactions. Explain. (4M)
7. a) Discuss temperature dependence of susceptibility of para and ferro magnetic materials. (4M)
- b) Derive Clasius-Mossoti relation. Calculate the ratio between electronic and ionic polarizability of a dielectric having  $\epsilon = 4.94$  and  $n^2 = 2.69$ . Where ' $\epsilon$ ' is dielectric constant and ' $n$ ' is refractive index. (10M)



Code No: R161201

**R16**

**SET - 1**

**I B. Tech II Semester Regular Examinations, April/May - 2017**  
**ENGLISH-II**  
(Com. to All Branches)

Time: 3 hours

Max. Marks: 70

Note: 1. Question Paper consists of two parts (**Part-A** and **Part-B**)  
2. Answering the question in **Part-A** is Compulsory  
3. Answer any **FOUR** Questions from **Part-B**

~~~~~

PART -A

1. a) What is the layman's view of atomic bomb? How right is he in thinking so? (2M)
- b) Define culture shock with various symptoms of it. (2M)
- c) What is public health surveillance and why is it important? (2M)
- d) What was the program Gates developed along with his friend and how did he market it? (2M)
- e) What were Kalam's contributions to DRDO? (2M)
- f) Name any two European scientists Bhabha was associated with and their contributions to the scientific world. (2M)
- g) What was Branley's experiment and what is its importance? (2M)

PART -B

2. a) How is the knowledge given by science different from what is acquired through education? Give examples from your learning experiences to support your answer. (5M)
- b) Mention any four great qualities of Dr. Kalam that made the world recognize him as a great scientist and leader. (4M)
- c) Write a letter to the Regional Manager of South Central Railways, Vijayawada complaining about the luggage/parcel you have not received which your friend has sent from IIT Mumbai. (5M)
3. a) Who do you think is to be held responsible for the destruction created by technology? Support your opinion with suitable examples. (5M)
- b) Write an email to your principal with a copy to your head of the department, asking him/her to permit your class to go on an industrial & educational tour for a week. (4M)
- c) List out the awards and achievements of Sir C.V. Raman. (5M)



4. a) How should one avoid culture shock before experiencing it when one goes to a new place? What precautions would help in living peacefully in a new place of new culture? (5M)
- b) **Fill in the blanks with suitable forms of the verbs given in the parenthesis.** (4M)
She _____ (look) for a house for the past one month. Finally, she _____ (find) one that suits her requirements. She _____ (want) a house that has a small garden and space to _____ (park) her car. She _____ (say) she _____ (love) to live in a house that _____ (have) cross ventilation. She _____ (move) into it tomorrow.
- c) Name the discoveries and inventions that Bhabha was associated with. How did they help him contribute better to our country? (5M)
5. a) How did lottery in the village change the lives of the people? What could be done to make the villagers' lives better? (5M)
- b) Why and how do you think J.C.Bose remained an ideal scientist in principle and practice? State instances from his life that support your opinion. (4M)
- c) Write an essay on "Importance of Technical Education" in about 300 to 350 words. (5M)
6. a) What kind of health problems are common in India in relation to climate changes? What steps are to be taken by the public and government to prevent health hazards caused due to climate changes? (5M)
- b) Give a note on P.C. Ray's discoveries and their properties. (5M)
- c) **Give one word substitutes for the following and use the word in your own sentence:** (4M)
i) Hard to please
ii) A great lover of books
iii) Having a ready disposition to fight
iv) Someone who is the first to think/make something
7. a) What do you think are the qualities of Bill Gates that made him a successful professional? Give examples from the text to support your answer. (5M)
- b) How did Hardy help Ramanujan personally and professionally? (5M)
- c) **Rewrite the following sentences correcting the errors:** (4M)
i) I started late at my house. Thought I can take a cab to reach my office in time.
ii) He plays football when he was free.
iii) He drunk coffee everyday when he was young.
iv) Had your breakfast in the morning?



I B. Tech II Semester Regular Examinations, April/May – 2017
ENGLISH-II
 (Com. to All Branches)

Time: 3 hours

Max. Marks: 70

Note: 1. Question Paper consists of two parts (**Part-A** and **Part-B**)
 2. Answering the question in **Part-A** is Compulsory
 3. Answer any **FOUR** Questions from **Part-B**

~~~~~

**PART -A**

1. a) What is the foremost task of education according to the text “The Greatest Source- Education”? (2M)
- b) How is the attitude of the local people towards a person who is under culture shock? (2M)
- c) Who is Paul Allen and how did he contribute to Microsoft? (2M)
- d) Explain the process of lottery in the village and state whether it is democratic. (2M)
- e) What is Kalam’s role in SLV-3 project that made it successful? (2M)
- f) Explain Raman Effect. (2M)
- g) What were the unique achievements of Ramanujan? (2M)

**PART -B**

2. a) Does our education system help us find the difference between science and education? Give reasons to support your point of view. (4M)
- b) What qualities of Abdul Kalam made him the world’s admirable scientist? How do you think he has developed them? (5M)
- c) Write a dialogue between you and your friend who has come from a school where he is not very much exposed to English. He feels he is not fit for the course and needs to quit. However, his previous ranks and marks show that he is brilliant. Convince him instilling some courage using your soft skills. (Your dialogue cannot be less than 10 exchanges-A+B) (5M)
3. a) Who is to be held responsible for the destructive use of scientific inventions- science or people? Give reasons/examples to support your opinion. (5M)
- b) What were Raman’s contributions to Indian Institute of Sciences? (5M)
- c) Write an email to the regional manager of Samsung, complaining about the malfunctioning of the refrigerator you bought last month. The service center manager refused to take up the issue as the product is in the guarantee period. Give details of your gadget and request for immediate action. (4M)



4. a) Why and when do variations in cultures lead to a shock to new comers? How do you think one can avoid any kind of culture shock? (5M)
- b) Why did Bhabha initiate Indian Nuclear programme? Do you think it is realistic and necessary for a country like India? Give reasons. (5M)
- c) **Fill in the blanks with suitable forms of the verbs given in the parenthesis.** (4M)  
I \_\_\_\_\_ (wait) for this news for the past one week. Finally, it \_\_\_\_\_ (come) but none \_\_\_\_\_ (be) ready to accept it. Our teacher \_\_\_\_\_ (leave) us to \_\_\_\_\_ (join) her family in Chennai. She \_\_\_\_\_ (tell) me this a week ago but did not officially announce. She \_\_\_\_\_ (vacate) her house tomorrow. So we \_\_\_\_\_ (think) of giving her a farewell today evening.
5. a) Is lottery morally justified? Give reasons with examples from the story “The Lottery”. (5M)
- b) Why did J.C.Bose remain against patenting his inventions? (5M)
- c) Write an essay on “Importance of Digital Literacy in Rural India”. (4M)
6. a) What are the different measures the author talks about to manage health problems caused due to climate changes? (5M)
- b) What were the achievements and awards won by P.C. Ray? How did they contribute to the scientific world? (5M)
- c) **Give one word substitutes for the following and use the word in your own sentence:** (4M)  
i) A remedy for all diseases  
ii) One who can speak two languages  
iii) A word opposite in meaning  
iv) A person who never drinks alcohol
7. a) What do you think is the role of Gates parents in his success? Can similar kind of home environment lead to anyone’s success? Give reasons. (5M)
- b) What were the circumstances that helped Ramanujan go to England and why did he return to India? (5M)
- c) **Rewrite the following sentences correcting the errors:** (4M)  
i) I waved at my friend’s car. Thought he will stop to pick me up.  
ii) They gathered under the tree and discusses the agenda of the meeting.  
iii) She sung a very melodious song yesterday in the competition.  
iv) You saw the doctor yesterday?





**I B. Tech II Semester Regular Examinations, April/May – 2017**  
**ENGLISH-II**  
 (Com. to All Branches)

Time: 3 hours

Max. Marks: 70

Note: 1. Question Paper consists of two parts (**Part-A** and **Part-B**)  
 2. Answering the question in **Part-A** is Compulsory  
 3. Answer any **FOUR** Questions from **Part-B**

~~~~~

PART -A

1. a) What is the scientific dilemma a layman is linked with and why? (2M)
- b) What is the role of language in helping us recover from culture shock? (2M)
- c) How is temperature directly related to the death rate of a place? (2M)
- d) What did Gates feel about the free distribution of his software and what did he write in his open letter? (2M)
- e) How was Kalam involved with Pokhran-II project? (2M)
- f) How was TIFR founded and what were its research areas? (2M)
- g) Name the top most award in the field of science that Bose received. What was it given for? (2M)

PART -B

2. a) Describe how education can be the greatest source for civilization. Give suitable examples to support your answer. (5M)
- b) Why do you think Dr. Kalam was nominated as President of India unanimously? Give reasons highlighting his qualities/characteristics. (4M)
- c) You are the president of the students' union of your college. Write a letter to the officer-in-charge of the hostels of your college explaining the problems faced by the students. Suggest some solutions and request for immediate action. (5M)
3. a) Is it possible to have a scientific invention without any evil effects? Support your answer with suitable examples from our day to day use of scientific inventions. (5M)
- b) Was Raman's career as a scientist a smooth one? Give reasons to support your answer. (5M)
- c) Write an email to your district collector asking him to provide more beds and a proper qualified doctor at all the health centers in the rural places of your district which would improve the living conditions in the villages. (4M)



4. a) How is culture shock caused and what are the various strategies a person can adopt to overcome culture shock? (5M)
- b) How did Bhabha contribute to Atomic Energy Commission in India? (5M)
- c) **Fill in the blanks with suitable forms of the verbs given in the parenthesis.** (4M)
She _____ (look) for a house for the past one month. Finally, she _____ (find) one that suits her requirements. She _____ (want) a house that has a small garden and space to _____ (park) her car. She _____ (say) she _____ (love) to live in a house that _____ (have) cross ventilation. She _____ (move) into it tomorrow.
5. a) Explain the practice of lottery in the village. Do you think it is the right one? Give reasons to support your opinion. (5M)
- b) Mention the famous devices designed by J.C.Bose. Describe their functioning and importance. (5M)
- c) Write an essay on "Importance of Protecting One's Culture". (4M)
6. a) What kind of health problems do Indians face due to climate changes? How can they be prevented? (5M)
- b) Give details of contributions of P.C Ray as a scientist, entrepreneur and socialist to India. (5M)
- c) **Give one word substitutes for the following and use the word in your own sentence:** (4M)
i) Detailed plan of a journey
ii) Person who works in the same department/office
iii) One who travels in space
iv) A small shop that sells fashionable clothes, cosmetics etc.
7. a) Explain the social services rendered by Bill Gates as Philanthropist. (5M)
- b) What were the strengths and weaknesses of Ramanujan as a mathematician according to Hardy? (5M)
- c) **Rewrite the following sentences correcting the errors:** (4M)
i) I keep smiling at the blind man at the bus stop. Although I knew he cannot see my smile.
ii) She looked at the cake and immediately orders for it.
iii) She written the report yesterday.
iv) Had your lunch in the afternoon?



Code No: R161201

R16

SET - 4

I B. Tech II Semester Regular Examinations, April/May – 2017
ENGLISH-II
(Com. to All Branches)

Time: 3 hours

Max. Marks: 70

- Note: 1. Question Paper consists of two parts (**Part-A** and **Part-B**)
2. Answering the question in **Part-A** is Compulsory
3. Answer any **FOUR** Questions from **Part-B**
- ~~~~~

PART -A

1. a) Why does the author say that the 'know-how' produced by science and technology is an 'unfinished sentence'? (2M)
- b) How can one control air pollution and manage it? (2M)
- c) How do people express their culture shock? (2M)
- d) What is public health surveillance and why is it important? (2M)
- e) What was Kalam's role in building indigenous rockets in India? (2M)
- f) Describe the work of Raman that made him to achieve the Noble Prize. (2M)
- g) Name some awards P. C. Ray won. What were they given for? (2M)

PART -B

2. a) What is the prime source for civilizations to come into existence and disappear? Do you agree with the author's argument? Justify. (5M)
- b) Why do you think Dr. Kalam is called "The Missile Man of India"? How did his scientific contributions help our country? (5M)
- c) Write a letter to the Editor of the Hindu newspaper stating the present hot summer days and the bad status of bus shelters that cannot give shade resulting in deaths due to sunstroke at many places. (4M)
3. a) Describe any modern invention that the present generation is obsessed with. Write the positive and negative effects it has on the society. Who should be praised or held responsible for these effects? (5M)
- b) What were the challenges Raman faced in his life and career? How did he overcome them? (5M)
- c) Write an email to the regional manager of Whirlpool, complaining about the malfunctioning of the washing machine you bought last month. The service center manager refused to take up the issue as the product is in the guarantee period. Give details of your gadget and request for immediate action. (4M)



4. a) Elaborate with examples on how language variations contribute to culture shock. (5M)
b) How did Bhabha's education help him contribute better to our country's scientific and academic progress? (5M)
c) **Fill in the blanks with suitable forms of the verbs given in the parenthesis.** (4M)
I _____ (wait) for this news for the past one week. Finally, it _____ (come) but none _____ (be) ready to accept it. Our teacher _____ (leave) us to _____ (join) her family in Chennai. She _____ (tell) me this a week ago but did not officially announce. She _____ (vacate) her house tomorrow. So we _____ (think) of giving her a farewell today evening.
5. a) What is black box in the story "The Lottery"? Who made it? When and why is it significant? (5M)
b) How could J.C. Bose establish the harmony between the living and non-living worlds? (5M)
c) Write an essay on "Making India a Developed Country" (4M)
6. a) Suggest some traditional measures to manage health problems caused due to climate changes? (5M)
b) How and when could P.C. Ray help his village people? (5M)
c) **Give one word substitutes for the following and use the word in your own sentence:** (4M)
i) Incapable of being seen through
ii) One who talks to people to help solve their problems
iii) One who talks in sleep
iv) That which can be easily broken
7. a) When and how did Bill Gates start building his own empire of business? Give the details of each stage. (5M)
b) How do you justify Srinivasa Ramanujan's birthday being celebrated as Mathematics day in India? (5M)
c) **Rewrite the following sentences correcting the errors:** (4M)
i) I gave a good gift to my friend. Which I bought in Dubai.
ii) They ride through the tunnel and stopped at the other end.
iii) The peon rung the bell when the clock showed 12.
iv) You came to see me now?



I B. Tech II Semester Regular Examinations, April/May – 2017
MATHEMATICS-III

(Com. to CE, EEE, ME, ECE, CSE, CHEM, EIE, IT, ECC, AE, AME, MM, PE, PCE, MET, AGE)

Time: 3 hours

Max. Marks: 70

- Note: 1. Question Paper consists of two parts (**Part-A** and **Part-B**)
 2. Answering the question in **Part-A** is Compulsory
 3. Answer any **FOUR** Questions from **Part-B**

PART -A

1. a) Find the rank of a matrix $A = \begin{bmatrix} -1 & 2 & 1 & 8 \\ 2 & 1 & -1 & 0 \\ 3 & 2 & 1 & 7 \end{bmatrix}$ (2M)
- b) Prove that if λ is an eigen value of a matrix A then λ^{-1} is an eigen value of the matrix A^{-1} if it exists. (2M)
- c) Evaluate $\int_0^1 \int_0^1 \int_{\sqrt{x^2+y^2}}^y xyz \, dzdydx$. (2M)
- d) Find the value of $\Gamma\left(\frac{5}{2}\right)$. (2M)
- e) Find the angle between the surface $x^2 + y^2 + z^2 = 9$ and $z = x^2 + y^2 - 3$ at (2, -1, 2). (2M)
- f) If $\vec{F} = (5xy - 6x^2)\vec{i} + (2y - 4x)\vec{j}$ then evaluate $\int \vec{F} \cdot d\vec{R}$ along the curve $y = x^3$ from the point (1, 1) to (2, 8). (2M)
- g) Write the quadratic form corresponding to the symmetric matrix $\begin{bmatrix} 1 & 0 & 4 \\ 0 & -2 & -1 \\ 4 & -1 & 3 \end{bmatrix}$. (2M)

PART -B

2. a) Solve the system of equations $20x + y - 2z = 17, 3x + 20y - z = -18, 2x - 3y + 20z = 25$ by Gauss Jacobi method. (7M)
- b) Find the currents in the following circuit (7M)

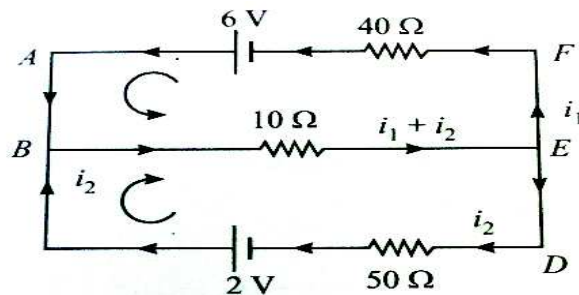

3. a) Verify Cayley-Hamilton theorem and find the inverse of the matrix (7M)
- $$A = \begin{bmatrix} 1 & 0 & 3 \\ 2 & 1 & -1 \\ 1 & -1 & 1 \end{bmatrix}$$
- b) Reduce the quadratic form $2x^2 + 2y^2 + 2z^2 - 2xy - 2yz - 2zx$ to canonical form by orthogonal transformation and hence find rank, index, signature and nature of the quadratic form. (7M)
4. a) Trace the curve $r^2 = a^2 \cos 2\theta$. (7M)
- b) Evaluate $\int_0^a \int_{\frac{x}{a}}^{2a-x} x y^2 dy dx$ by changing the order of integration. (7M)
5. a) Express $\int_0^1 x^m (1-x^n)^p dx$ in terms of Γ functions and hence evaluate $\int_0^1 x^5 (1-x^3)^{10} dx$. (6M)
- b) Evaluate $\int_0^{\frac{\pi}{2}} \sin^5 \theta \cos^7 \theta d\theta$ by using β, Γ functions. (4M)
- c) Express $\int_0^4 \sqrt{x}(4-x)^{3/2} dx$ in terms of β function. (4M)
6. a) Show that the vector field $\vec{F} = (x^2 - yz)\vec{i} + (y^2 - zx)\vec{j} + (z^2 - xy)\vec{k}$ is conservative and find the scalar potential function corresponding to it. (7M)
- b) Show that $\nabla \cdot (\vec{F} \times \vec{G}) = \vec{G} \cdot (\nabla \times \vec{F}) - \vec{F} \cdot (\nabla \times \vec{G})$ (7M)
7. State Stoke's theorem and verify the theorem for $\vec{F} = (x+y)\vec{i} + (y+z)\vec{j} - x\vec{k}$ and S is the surface of the plane $2x + y + z = 2$, which is in the first octant. (14M)



I B. Tech II Semester Regular Examinations, April/May – 2017
MATHEMATICS-III

(Com. to CE, EEE, ME, ECE, CSE, CHEM, EIE, IT, ECC, AE, AME, MM, PE, PCE, MET, AGE)

Time: 3 hours

Max. Marks: 70

- Note: 1. Question Paper consists of two parts (**Part-A** and **Part-B**)
 2. Answering the question in **Part-A** is Compulsory
 3. Answer any **FOUR** Questions from **Part-B**

PART -A

1. a) Determine the rank of a matrix $A = \begin{bmatrix} 2 & -1 & 3 & 4 \\ 0 & 3 & 4 & 1 \\ 2 & 3 & 7 & 5 \\ 2 & 5 & 11 & 6 \end{bmatrix}$. (2M)
- b) Use Cayley-Hamilton theorem to find A^8 if $A = \begin{bmatrix} 1 & 2 \\ 2 & -1 \end{bmatrix}$. (2M)
- c) Evaluate $\int_0^1 \int_0^1 \int_0^y xyz \, dx dy dz$. (2M)
- d) Find the value of $\Gamma\left(-\frac{5}{2}\right)$. (2M)
- e) Find unit normal vector to the surface $x^2y + 2xz^2 = 8$ at the point $(1, 0, 2)$. (2M)
- f) If $\vec{F} = (3x^2 + 6y)\vec{i} - 14yz\vec{j} + 20xz\vec{k}$ then evaluate $\int \vec{F} \cdot d\vec{R}$ from $(0, 0, 0)$ to $(1, 1, 1)$ along the path $x = t, y = t^2, z = t^3$. (2M)
- g) Write the quadratic form corresponding to the symmetric matrix $\begin{bmatrix} 0 & 5/2 & 3 \\ 5/2 & 7 & 1 \\ 3 & 1 & 2 \end{bmatrix}$ (2M)

PART -B

2. a) Show that the system of equations is consistent (7M)
 $2x - y - z = 2, x + 2y + z = 2, 4x - 7y - 5z = 2$ and solve.
- b) Find the currents in the following circuit (7M)

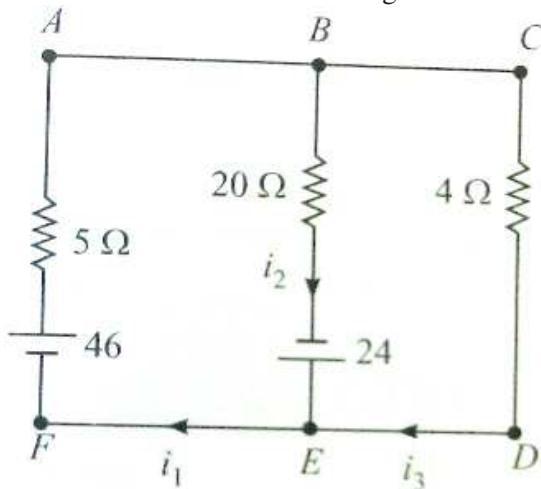

3. a) Reduce the quadratic form $6x_1^2 + 3x_2^2 + 3x_3^2 - 4x_1x_2 - 2x_2x_3 + 4x_1x_3$ to canonical form and hence state nature, rank, index and signature of the quadratic form. (7M)
- b) Determine the natural frequencies and normal modes of a vibrating system for which mass $m = \begin{bmatrix} 1 & 0 \\ 0 & 2 \end{bmatrix}$ and stiffness $k = \begin{bmatrix} 2 & 1 \\ 1 & 3 \end{bmatrix}$. (7M)
4. a) Trace the curve $y^2(2a - x) = x^3$. (7M)
- b) Evaluate $\int_0^\infty \int_0^\infty e^{-(x^2+y^2)} dx dy$ by changing in to polar coordinates and hence deduce $\int_0^\infty e^{-x^2} dx = \frac{\sqrt{\pi}}{2}$. (7M)
5. a) Show that $\beta(m, n) = \frac{\Gamma(m)\Gamma(n)}{\Gamma(m+n)}$. (6M)
- b) Evaluate $\int_0^\pi \sin^4\theta \cos^2\theta d\theta$ by using β, Γ functions. (4M)
- c) Express $\int_0^1 \frac{1}{(1-x^3)^{1/3}} dx$ in terms of β function. (4M)
6. a) Show that the vector field $\vec{F} = (x^2 + xy^2)\vec{i} + (y^2 + x^2y)\vec{j}$ is conservative and find the scalar potential function. (7M)
- b) Show that $\nabla(\nabla \cdot \vec{F}) = \nabla \times (\nabla \times \vec{F}) + \nabla^2 \vec{F}$. (7M)
7. State Greens theorem in plane and verify the theorem for $\oint_C [(y - \sin x)dx + \cos x dy]$, where C is the plane triangle formed by the lines $y = 0, x = \frac{\pi}{2}, y = \frac{2}{\pi}x$. (14M)



I B. Tech II Semester Regular Examinations, April/May – 2017
MATHEMATICS-III

(Com. to CE, EEE, ME, ECE, CSE, CHEM, EIE, IT, ECC, AE, AME, MM, PE, PCE, MET, AGE)

Time: 3 hours

Max. Marks: 70

- Note: 1. Question Paper consists of two parts (**Part-A** and **Part-B**)
2. Answering the question in **Part-A** is Compulsory
3. Answer any **FOUR** Questions from **Part-B**

PART -A

1. a) Determine the rank of a matrix $A = \begin{bmatrix} 1 & 2 & 3 & 0 \\ 2 & 4 & 3 & 2 \\ 3 & 2 & 1 & 3 \\ 6 & 8 & 7 & 5 \end{bmatrix}$. (2M)
- b) Use Cayley-Hamilton theorem and find A^{-1} if $A = \begin{bmatrix} 1 & 4 \\ 2 & 3 \end{bmatrix}$. (2M)
- c) Evaluate $\int_0^{\frac{\pi}{2}} \int_0^{\frac{a^2-r^2}{a}} \int_0^{\frac{a^2-r^2}{a}} r \, dz \, dr \, d\theta$. (2M)
- d) Show that $\beta\left(\frac{1}{2}, \frac{1}{2}\right) = \pi$. (2M)
- e) Find directional derivative of $\phi = xy^2 + yz^2$ at the point (2,-1,1) in the direction of the vector $\bar{i} + 2\bar{j} + 2\bar{k}$. (2M)
- f) If $\bar{F} = (x^2 - y)\bar{i} + (2xz - y)\bar{j} + z^2\bar{k}$ then evaluate $\int_C \bar{F} \cdot d\bar{R}$ where C is the straight line joining the points (0, 0, 0) to (1, 2, 4). (2M)
- g) Write the quadratic form corresponding to the symmetric matrix $\begin{bmatrix} 3 & 5 & 0 \\ 5 & 5 & 4 \\ 0 & 4 & 7 \end{bmatrix}$. (2M)

PART -B

2. a) Solve the system of equations $10x + y + z = 12$, $2x + 10y + z = 13$, $2x + 2y + 10z = 14$ by Gauss Seidel method. (7M)
- b) Find the currents in the following circuit (7M)

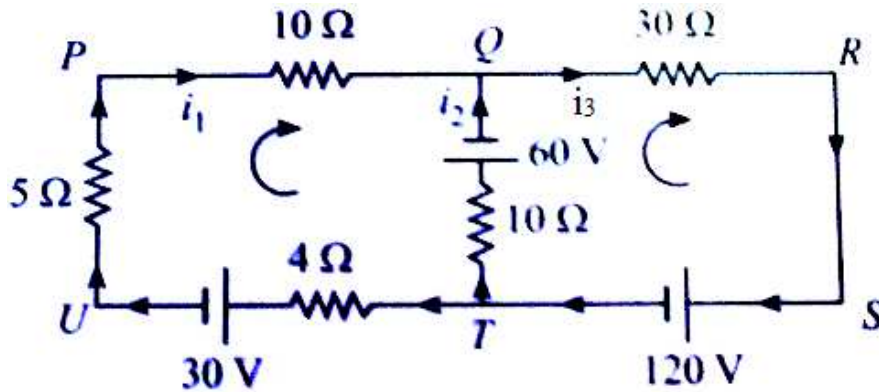

3. a) Reduce the quadratic form $3x^2 + 5y^2 + 3z^2 - 2xy - 2yz + 2zx$ to canonical form by orthogonal transformation and hence find the rank, index signature and nature of the quadratic form. (7M)
- b) Find the natural frequencies and normal modes of a vibrating system (7M)
 $mx'' + kx = 0$ for mass $m = \begin{bmatrix} 2 & 0 \\ 0 & 1 \end{bmatrix}$ and stiffness $k = \begin{bmatrix} 9 & -3 \\ -3 & 3 \end{bmatrix}$.
4. a) Trace the curve $a^2y^2 = x^2(a^2 - x^2)$. (7M)
- b) Evaluate $\int_0^1 \int_{\sqrt{y}}^{2-y} xy \, dx \, dy$ by changing the order of integration. (7M)
5. a) Show that $\Gamma\left(\frac{1}{2}\right) = \sqrt{\pi}$. (6M)
- b) Evaluate $\int_0^{\frac{\pi}{2}} \sin^5 \theta \, d\theta$ by using β, Γ functions. (4M)
- c) Express $\int_0^1 \frac{x \, dx}{\sqrt{1+x^4}}$ in terms of β function. (4M)
6. a) Find the constants a, b such that the surfaces $5x^2 - 2yz - 9x = 0$ and $ax^2y + bz^3 = 4$ cut orthogonally at (1,-1,2). (7M)
- b) Show that $\nabla \times (\nabla \times \vec{F}) = \nabla(\nabla \cdot \vec{F}) - \nabla^2 \vec{F}$. (7M)
7. State Gauss divergence theorem in plane and verify the theorem for $\vec{F} = 4xz\vec{i} - y^2\vec{j} + zy\vec{k}$ over the cube $x = 0, x = 1, y = 0, y = 1, z = 0, z = 1$. (14M)



I B. Tech II Semester Regular Examinations, April/May – 2017
MATHEMATICS-III

(Com. to CE, EEE, ME, ECE, CSE, CHEM, EIE, IT, ECC, AE, AME, MM, PE, PCE, MET, AGE)

Time: 3 hours

Max. Marks: 70

- Note: 1. Question Paper consists of two parts (**Part-A** and **Part-B**)
 2. Answering the question in **Part-A** is Compulsory
 3. Answer any **FOUR** Questions from **Part-B**

PART -A

1. a) Find inverse of the matrix $A = \begin{bmatrix} 1 & 1 & 3 \\ 1 & 3 & -3 \\ -2 & -4 & -4 \end{bmatrix}$ by elementary operations. (2M)
- b) Prove that if λ is an eigen value of a matrix A then $\frac{|A|}{\lambda}$ is an eigen value of $\text{adj}A$. (2M)
- c) Evaluate $\int_0^1 \int_{y^2}^1 \int_0^{1-x} x \, dz \, dx \, dy$. (2M)
- d) Determine the value of $\beta(2, 3)$. (2M)
- e) Show that $\nabla f g = f \nabla g + g \nabla f$. (2M)
- f) If $\vec{F} = x^2 y^2 \vec{i} + y \vec{j}$ then evaluate $\int_C \vec{F} \cdot d\vec{R}$ where C is the curve $y^2 = 4x$ in the XY plane from (0, 0) to (4, 4). (2M)
- g) Write the quadratic form corresponding to the symmetric matrix (2M)

$$\begin{bmatrix} 2 & -3 & 5 \\ -3 & 2 & -2 \\ 5 & -2 & 2 \end{bmatrix}$$

PART -B

2. a) Solve the system of equations (7M)

$$x + 10y + z = 6, \quad 10x + y + z = 6, \quad x + y + 10z = 6$$
 by Gauss Seidel method.
- b) Find the currents in the following circuit (7M)

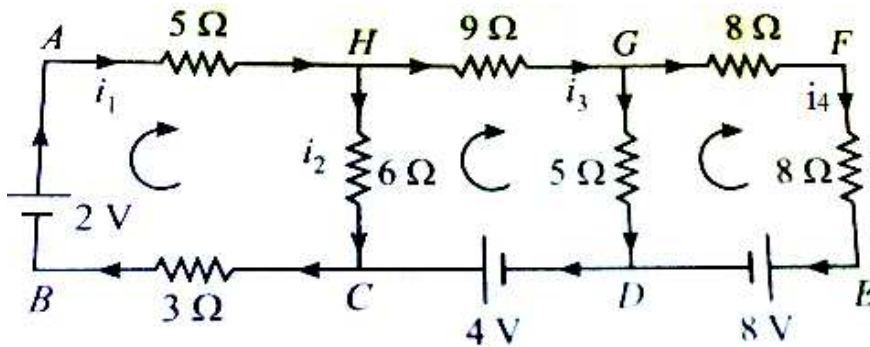

3. a) Verify Cayley-Hamilton theorem for the matrix $A = \begin{bmatrix} 1 & 2 & -1 \\ 2 & 1 & -2 \\ 2 & -2 & 1 \end{bmatrix}$ and hence (7M)
find A^4 .
- b) Reduce the quadratic form $3x_1^2 + 5x_2^2 + 3x_3^2 - 2x_1x_2 - 2x_1x_3 + 2x_2x_3$ to (7M)
canonical form and hence state nature, rank, index and signature of the quadratic
form.
4. a) Trace the curve $r = a \sin 3\theta$. (7M)
- b) Evaluate $\int_0^a \int_0^{\sqrt{a^2-x^2}} y \sqrt{x^2+y^2} dy dx$ by transforming to polar coordinates. (7M)
5. a) Establish a relation between β and Γ functions. (6M)
- b) Evaluate $\int_0^{\frac{\pi}{2}} \cos^7 \theta d\theta$ by using β, Γ functions. (4M)
- c) Express $\int_0^1 \frac{x dx}{\sqrt{1-x^5}}$ in terms of β function. (4M)
6. a) Find the angle between the surfaces $ax^2 + y^2 + z^2 - xy = 1$ and conservative (7M)
 $bx^2y + y^2z + z = 1$ at $(1, 1, 0)$.
- b) Show that $\vec{F} = (y^2 - z^2 + 3yz - 2x)\vec{i} + (3xz + 2xy)\vec{j} + (3xy - 2xz + 2z)\vec{k}$ (7M)
is both solenoidal and irrotational.
7. a) State Greens theorem in plane and apply the theorem to evaluate $\oint_C x^2y dx + (7M)$
 y^3dy , where C is the closed path formed by $y = x$, $y = x^3$ from $(0, 0)$ to $(1, 1)$.
- b) Evaluate $\int_S \vec{F} \cdot \vec{dS}$ using Gauss divergence theorem, where $\vec{F} = 2xy\vec{i} + yz^2\vec{j}$ (7M)
 $+ z\vec{k}$ and S is the surface of the region bounded by $x = 0$, $y = 0$, $z = 0$,
 $x + 2z = 6$.



I B. Tech II Semester Regular Examinations, April/May - 2017
MATHEMATICS-II (MM)
 (Com. to CE, EEE, ME, CHEM, AE, BIO, AME, MM, PE, PCE, MET)

Time: 3 hours

Max. Marks: 70

- Note: 1. Question Paper consists of two parts (**Part-A** and **Part-B**)
 2. Answer **ALL** the question in **Part-A**
 3. Answer any **FOUR** Questions from **Part-B**

PART -A

1. a) Explain the Bisection method. (2M)
- b) Prove that $\Delta = E - 1$. (2M)
- c) Write Newton's forward interpolation formula. (2M)
- d) Write Trapezoidal rule and Simpson's $3/8^{\text{th}}$ rule. (2M)
- e) Write the Fourier series for $f(x)$ in the interval $(0, 2\pi)$. (2M)
- f) Write One dimensional wave equation with boundary and initial conditions. (2M)
- g) If $F(s)$ is the complex Fourier transform of $f(x)$, then prove that (2M)

$$F\{f(ax)\} = \frac{1}{a} F\left(\frac{s}{a}\right).$$

PART -B

2. a) Using bisection method, obtain an approximate root of the equation $x^3 - x - 1 = 0$. (7M)
- b) Develop an Iterative formula to find the square root of a positive number N using Newton-Raphson method. (7M)
3. a) Evaluate $\Delta^2 (\tan^{-1} x)$. (6M)
- b) Using Newton's forward formula, find the value of $f(1.6)$, if (8M)

x	1	1.4	1.8	2.2
$f(x)$	3.49	4.82	5.96	6.5



4. a) Compute the value of $\int_{0.2}^{1.4} (\sin x - \log x + e^x) dx$ using Simpson's $\frac{3}{8}$ th rule. (7M)
- b) Using the fourth order Runge – Kutta formula, find $y(0.2)$ and $y(0.4)$ given that (7M)

$$\frac{dy}{dx} = \frac{y^2 - x^2}{y^2 + x^2}, y(0) = 1.$$

5. a) Find a Fourier series to represent $f(x) = x - x^2$ in $-\pi \leq x \leq \pi$. Hence show that (7M)

$$\frac{1}{1^2} - \frac{1}{2^2} + \frac{1}{3^2} - \frac{1}{4^2} + \dots = \frac{\pi^2}{12}.$$

- b) Obtain the half range sine series for $f(x) = e^x$ in $0 < x < 1$. (7M)

6. a) Solve by the method of separation of variables (7M)

$$4u_x + u_y = 3u \text{ and } u(0, y) = e^{-5y}.$$

- b) A tightly stretched string with fixed end points $x = 0$ and $x = L$ is initially in a (7M)

position given by $y = y_0 \sin^3\left(\frac{\pi x}{L}\right)$ if it is released from rest from this position,

find the displacement $y(x, t)$.

7. a) Express the function $f(x) = \begin{cases} 1 & \text{for } |x| \leq 1 \\ 0 & \text{for } |x| \geq 1 \end{cases}$ as a Fourier integral. Hence (7M)

$$\text{evaluate } \int_0^{\infty} \frac{\sin \lambda \cos \lambda x}{\lambda} d\lambda.$$

- b) Find the Fourier transform of $f(x) = \begin{cases} 1 - x^2 & \text{for } |x| \leq 1 \\ 0 & \text{for } |x| > 1 \end{cases}$ hence evaluate (7M)

$$\int_0^{\infty} \left(\frac{x \cos x - \sin x}{x^3} \right) \cos \frac{x}{2} dx.$$



I B. Tech II Semester Regular Examinations, April/May - 2017
MATHEMATICS-II (MM)
 (Com. to CE, EEE, ME, CHEM, AE, BIO, AME, MM, PE, PCE, MET)

Time: 3 hours

Max. Marks: 70

- Note: 1. Question Paper consists of two parts (**Part-A** and **Part-B**)
 2. Answer **ALL** the question in **Part-A**
 3. Answer any **FOUR** Questions from **Part-B**

PART -A

1. a) Explain the Method of false position. (2M)
- b) Prove that $\nabla = 1 - E^{-1}$. (2M)
- c) Write Newton's backward interpolation formula. (2M)
- d) Write Simpson's $1/3^{\text{rd}}$ and $3/8^{\text{th}}$ rule. (2M)
- e) Write the Fourier series for $f(x)$ in the interval $(0, 2L)$. (2M)
- f) Write the suitable solution of one dimensional wave equation. (2M)
- g) If $F(s)$ is the complex Fourier transform of $f(x)$, then prove that (2M)

$$F\{f(x-a)\} = e^{i a s} F(s).$$

PART -B

2. a) Using bisection method, compute the real root of the equation $x^3 - 4x + 1 = 0$. (7M)
- b) Develop an Iterative formula to find the cube root of a positive number N using Newton-Raphson method. (7M)
3. a) Evaluate $\Delta (e^x \log 2x)$. (6M)
- b) Using Newton's forward formula compute $f(142)$ from the following table: (8M)

x	140	150	160	170	180
$f(x)$	3.685	4.854	6.302	8.076	10.225

4. a) Evaluate, $\int_0^2 e^{-x^2} dx$ by using Trapezoidal rule and Simpson's $\frac{1}{3}^{\text{rd}}$ rule taking (7M)
 $h = 0.25$.
- b) Find the value of y at $x = 0.1$ by Picard's method, given that (7M)

$$\frac{dy}{dx} = \frac{y-x}{y+x}, \quad y(0) = 1.$$



5. a) Given that $f(x) = \begin{cases} -\pi, & -\pi < x < 0 \\ x, & 0 < x < \pi \end{cases}$. Find the Fourier series for $f(x)$. (7M)

Also deduce that $\frac{1}{1^2} + \frac{1}{3^2} + \frac{1}{5^2} + \frac{1}{7^2} + \dots = \frac{\pi^2}{8}$.

- b) Express $f(x) = x$ as a half-range cosine series in $0 < x < 2$. (7M)
6. a) Solve by the method of separation of variables (7M)
- $$\frac{\partial u}{\partial x} = 2 \frac{\partial u}{\partial t} + u, \text{ given } u(x, 0) = 6e^{-3x}.$$
- b) A string of length L is initially at rest in equilibrium position and each of its points (7M)
- is given the velocity $\left(\frac{\partial y}{\partial t}\right)_{t=0} = b \sin^3\left(\frac{\pi x}{L}\right)$. Find displacement $y(x, t)$.

7. a) Express $f(x) = \begin{cases} 1 & \text{for } 0 \leq x \leq \pi \\ 0 & \text{for } x > \pi \end{cases}$ as a Fourier sine integral and hence evaluate (7M)

$$\int_0^{\infty} \frac{1 - \cos(\pi\lambda)}{\lambda} \sin(x\lambda) d\lambda.$$

- b) Find the Fourier sine and cosine transform of (7M)
- $$f(x) = e^{-ax}, a > 0, x > 0.$$



I B. Tech II Semester Regular Examinations, April/May - 2017
MATHEMATICS-II (MM)
 (Com. to CE, EEE, ME, CHEM, AE, BIO, AME, MM, PE, PCE, MET)

Time: 3 hours

Max. Marks: 70

Note: 1. Question Paper consists of two parts (**Part-A** and **Part-B**)
 2. Answer **ALL** the question in **Part-A**
 3. Answer any **FOUR** Questions from **Part-B**

PART -A

1. a) Explain the Newton-Raphson method. (2M)
 - b) Prove that $\delta = E^{1/2} - E^{-1/2}$. (2M)
 - c) Write Lagrange's interpolation formula for unequal intervals. (2M)
 - d) Explain Taylor's series method for solving IVP $\frac{dy}{dx} = f(x, y)$ with $y(x_0) = y_0$. (2M)
 - e) Write the Fourier series for $f(x)$ in the interval $(-\pi, \pi)$. (2M)
 - f) Write the suitable solution of one dimensional heat equation. (2M)
 - g) If $F(s)$ is the complex Fourier transform of $f(x)$, then prove that (2M)
- $$F\{f(x)\cos ax\} = \frac{1}{2}[F(s+a) + F(s-a)].$$

PART -B

2. a) Using Regula-Falsi method, compute the real root of the equation $x^3 - 4x - 9 = 0$. (7M)
- b) Develop an Iterative formula to find $\frac{1}{N}$. Using Newton-Raphson method. (7M)
3. a) Evaluate $\Delta \left(\frac{x^2}{\cos 2x} \right)$. (6M)
- b) Compute $f(27)$ Using Lagrange's formula from the following table: (8M)

x	14	17	31	35
$f(x)$	68.7	64.0	44.0	39.1



4. a) Evaluate $\int_0^{0.6} e^{-x^2} dx$ by using Simpson's $\frac{1}{3}$ rule taking seven ordinates. (7M)
- b) Given that $\frac{dy}{dx} = 2 + \sqrt{xy}$, $y(1) = 1$. (7M)
Find $y(2)$ in steps of **0.2** using the Euler's method.
5. a) Find the Fourier series for the function $f(x) = \begin{cases} x & , 0 \leq x \leq \pi \\ 2\pi - x & , \pi \leq x \leq 2\pi \end{cases}$. (7M)
Also deduce that $\frac{1}{1^2} + \frac{1}{3^2} + \frac{1}{5^2} + \frac{1}{7^2} + \dots = \frac{\pi^2}{8}$.
- b) Obtain the Fourier expansion of $f(x) = x \sin x$ as a cosine series in $(0, \pi)$. (7M)
6. Solve the Laplace's equation $\frac{\partial^2 u}{\partial x^2} + \frac{\partial^2 u}{\partial y^2} = 0$ in a rectangle in the xy -plane, (14M)
 $0 \leq x \leq a$ and $0 \leq y \leq b$ satisfying the following boundary condition
 $u(0, y) = 0, u(a, y) = 0, u(x, b) = 0$ and $u(x, 0) = f(x)$.
7. a) Find the Fourier sine transform of the function (7M)
 $f(x) = \begin{cases} x & , 0 < x < 1 \\ 2 - x & , 1 < x < 2 \\ 0 & , x > 2 \end{cases}$.
- b) Find the Fourier cosine integral and Fourier sine integral of (7M)
 $f(x) = e^{-kx}, k > 0$.



I B. Tech II Semester Regular Examinations, April/May - 2017
MATHEMATICS-II (MM)
 (Com. to CE, EEE, ME, CHEM, AE, BIO, AME, MM, PE, PCE, MET)

Time: 3 hours

Max. Marks: 70

- Note: 1. Question Paper consists of two parts (**Part-A** and **Part-B**)
 2. Answer **ALL** the question in **Part-A**
 3. Answer any **FOUR** Questions from **Part-B**

PART -A

1. a) Explain Iteration method. (2M)
- b) Prove that $\mu = \frac{1}{2}(E^{1/2} + E^{-1/2})$. (2M)
- c) Prove that $\Delta^3 y_2 = \nabla^3 y_5$. (2M)
- d) Explain Runge-Kutta method of fourth order for solving IVP (2M)
 $\frac{dy}{dx} = f(x, y)$ with $y(x_0) = y_0$.
- e) Write the Fourier series for $f(x)$ in the interval $(-L, L)$. (2M)
- f) Write the various possible solutions of two-dimensional Laplace equation. (2M)
- g) If $F(s)$ and $G(s)$ are the complex Fourier transform of $f(x)$ and $g(x)$, then (2M)
 prove that $F\{a f(x) + b g(x)\} = a F(s) + b G(s)$.

PART -B

2. a) Find a positive real root of the equation $x^4 - x - 10 = 0$ using Newton-Raphson's method. (7M)
- b) Explain the bisection method. (7M)
3. a) Evaluate $\Delta^2 (\cos 2x)$. (6M)
- b) Using Newton's backward formula compute $f(84)$ from the following table: (8M)

x	40	50	60	70	80	90
$f(x)$	184	204	226	250	276	304



4. a) Evaluate $\int_0^1 e^{-x^2} dx$ by using Trapezoidal rule with $n = 10$. (7M)
- b) Obtain Picard's second approximate solution of the initial value problem (7M)
- $$\frac{dy}{dx} = \frac{x^2}{y^2 + 1}, y(0) = 0.$$
5. a) Obtain the Fourier series $f(x) = \left(\frac{\pi - x}{2}\right)^2$ in the interval $0 < x < 2\pi$. Deduce that (8M)
- $$\frac{1}{1^2} + \frac{1}{2^2} + \frac{1}{3^2} + \frac{1}{4^2} + \dots = \frac{\pi^2}{6}.$$
- b) Express $f(x) = x$ as a half-range cosine series in $0 < x < 2$. (6M)
6. a) Solve by the method of separation of variables (7M)
- $$\frac{\partial u}{\partial x} = 4 \frac{\partial u}{\partial y} \quad \text{and} \quad u(0, y) = 8e^{-3y}.$$
- b) Solve the Laplace's equation $\frac{\partial^2 u}{\partial x^2} + \frac{\partial^2 u}{\partial y^2} = 0$ in a rectangle in the xy -plane, (7M)
- $0 \leq x \leq a$ and $0 \leq y \leq b$ satisfying the following boundary condition
- $$u(x, 0) = 0, u(x, b) = 0, u(0, y) = 0 \text{ and } u(a, y) = f(y).$$
7. a) Find the Fourier cosine integral and Fourier sine integral of (7M)
- $$f(x) = e^{-ax} - e^{-bx}, \quad a > 0, b > 0.$$
- b) Find the Fourier transform of $e^{-a^2 x^2}$, $a > 0$. Hence deduce that $e^{-\frac{x^2}{2}}$ is self (7M)
- reciprocal in respect of Fourier transform.

