

Created by PDF Combine Unregistered Version

If you want to remove the watermark, Please register

Created by PDF Combine Unregistered Version

If you want to remove the watermark, Please register

Subject Code: R13109/R13

I B. Tech I Semester Regular Examinations Feb./Mar. - 2014

Set No - 1

ENGINEERING DRAWING

(Common to ECE, EIE, Bio-Tech, EComE, Agri.E)

Time: 3 hours

Max. Marks: 70

Question Paper Consists of **Part-A** and **Part-B**
Answering the question in **Part-A** is Compulsory,
Three Questions should be answered from **Part-B**

PART-A

1.(a) Draw the isometric view of Fig.1.

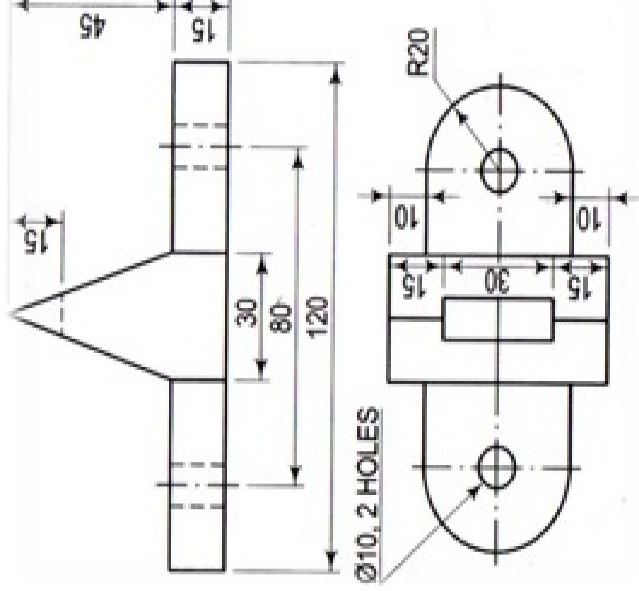

Note: All dimensions are in mm.

Fig.1

(b) Draw the projections of the straight line AB of 100 mm length when one of its ends is touching V.P and the other end is touching HP. The angles of inclination with H.P and V.P are 40° and 50° respectively.

[12+10]

PART-B

2.(a) The area of a field is 50000 sq m. The length and the breadth of the field, on the map is 10 cm and 8 cm respectively. Construct a diagonal scale which can read up to one metre. Mark the length of 235 metre on the scale. What is R.F of the scale?
(b) The foci of an ellipse are 90 mm apart and the minor axis is 72 mm long. Determine the length of the major axis. Construct the ellipse.

[8+8]

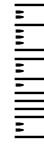

- 3.(a) Two points A and B are in H.P. The point A is 30 mm in front of the V.P while B is behind the V.P. The distance between their projectors is 75 mm and the line joining their top views makes an angle of 45° with xy. Find the distance of the point B from the V.P. [8+8]
- (b) A line PQ 40 mm long is parallel to V.P and inclined at an angle of 30° to H.P. The lower end P is 15 mm above H.P and 20 mm in front of V.P. Draw the projections of the line. [8+8]
4. The front view of a line AB measures 65 mm and makes an angle of 45° with xy. A is in the H.P and the VT of the line is 15 mm below the H.P. The line is inclined at 30° to the V.P. Draw the projections of AB and find its true length and inclination with the H.P. Also locate its H.T. [16]
5. Draw the projections of the circle of 50 mm diameter resting in the H.P on a point A on the circumference, its plane inclined at 45° to the H.P and [16]
- (a) The top view of the diameter AB making 30° angle with the V.P
- (b) The diameter AB making 30° angle with the V.P. [16]
6. Draw the projections of a cylinder 75mm diameter and 100 mm long, lying on the ground with its axis inclined at 30° to the V.P and parallel to the ground. [16]
7. Draw (i) Front view (ii) Side view from the right (iii) Top view of Fig: 2 [16]

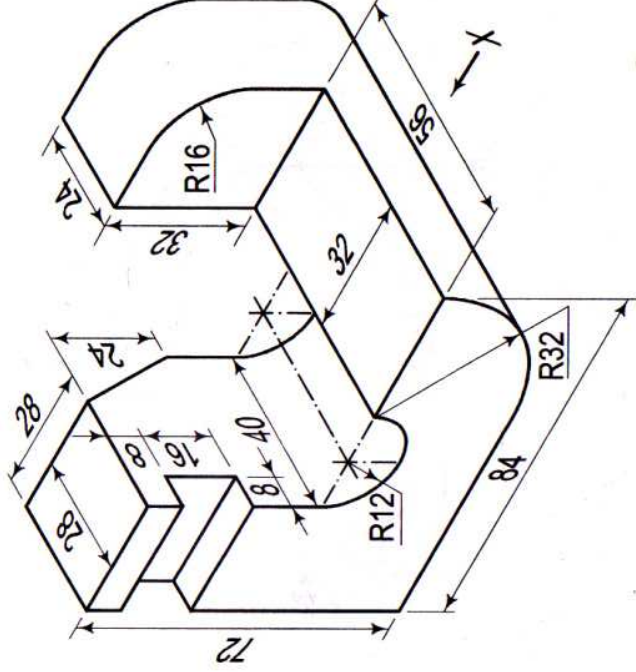

Note: All dimensions are in mm.

Fig: 2

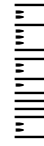

- 3.(a) The top view of a 75 mm long line measures 55 mm. The line is in the V.P, its one end being 25 mm above the H.P. Draw its projections. [8+8]
- (b) A point P is 15 mm above H.P and 20 mm in front of the V.P. Another point Q is 25 mm behind the V.P and 40 mm below the H.P. Draw projections of P and Q keeping the distance between their projectors equal to 90 mm. Draw straight lines joining (i) their top views and (ii) their front views.
4. A line PQ, 100 mm long, is inclined at 45° to the H.P and at 30° to the V.P. Its end P is in the second quadrant and Q is in the fourth quadrant. A point R on PQ, 40 mm from P is in both the planes. Draw the projections of PQ. [16]
5. Draw the projections of a regular hexagon of 25 mm side, having one of its sides in the H.P and inclined at 60° to the V.P and its surface making an angle of 45° with the H.P. [16]
6. Draw the projections of a cone, base 75 mm diameter and axis 100 mm long, lying on the H.P on one of its generators with the axis parallel to the V.P. [16]
7. Draw the isometric view of Fig.2: [16]

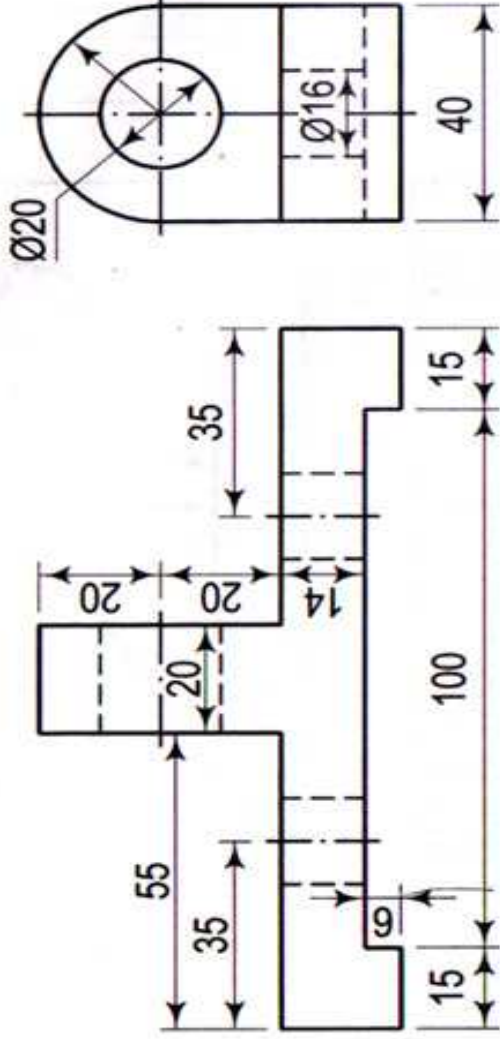

Note: All dimensions are in mm.

Fig.2

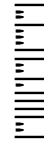

Subject Code: R13101/R13

Set No - 1

I B. Tech I Semester Regular Examinations Feb./Mar. - 2014

ENGLISH-I

(Common to All Branches)

Time: 3 hours

Max. Marks: 70

Question Paper Consists of **Part-A** and **Part-B**
Answering the question in **Part-A** is Compulsory,
Three Questions should be answered from **Part-B**

PART-A

- 1.(i) What does societal transformation result in?
 - (ii) What is L.A Hill's advice regarding the need to improve step by step thought?
 - (iii) What is a temperature belt?
 - (iv) What made Gandhi to think that he had to economize?
 - (v) How did the clergyman help Scoresby at school?
 - (vi) Bring out the difference between an average man and a scientist.
 - (vii) Explain the problem that Russell says is stark, dreadful and inescapable?
- [3+3+3+3+3+3+4]

PART-B

- 2.(a) "A writer ought to be a good reader in order to be a good writer". Elaborate Hill's views.
(b) Give an account of achievements of Gopinath. [8+8]
- 3.(a) Write about the universe as described by James Jeans.
(b) What are the circumstances under which super computer, generations & C-DAC started in India. [8+8]
- 4.(a) Describe the clergyman's character.
(b) Why was Naidu called the 'Edison of India'? [8+8]
- 5.(a) Write a summary of the essay 'The Scientific Point of View'.
(b) "We should make way for the youngsters instead of expecting them to come around to our ways". Do you agree with Sudha Murthy's statement? Give reasons. [8+8]
- 6.(a) What are the different phases of transformation in Gandhiji is life of London?
(b) Write an essay on 'Gender Discrimination'. [8+8]



- 7.(a) Write the Synonyms for the following words.
- (i) emulate
 - (ii) infatuation
 - (iii) disbursed
 - (iv) consent
- (b) Write the Antonyms for the following words.
- (i) abstract
 - (ii) impartial
 - (iii) natural
 - (iv) elaborate
- (c) Fill in the blanks with suitable Prepositions.
- (i) Kiran lives ----- 35 James street
 - (ii) He goes to his office ----- bus.
 - (iii) They are angry ----- you
 - (iv) I saw him ----- Sunday
- (d) Correct and rewrite the following sentences.
- (i) Every boy and every girl have to participate in the competition.
 - (ii) The property was shared among the two brothers.
 - (iii) I am reading a interesting story.
 - (iv) The boy was playing while it is raining.

[4+4+4+4]



Subject Code: R13101/R13

Set No - 2

I B. Tech I Semester Regular Examinations Feb./Mar. - 2014

ENGLISH-I

(Common to All Branches)

Time: 3 hours

Max. Marks: 70

Question Paper Consists of **Part-A** and **Part-B**
Answering the question in **Part-A** is Compulsory,
Three Questions should be answered from **Part-B**

PART-A

- 1.(i) What does Russell want the public to realize the facts about hydrogen bombs?
- (ii) What are the biological effects of American civil war on the negro population? What are the causes for it according to Haldane?
- (iii) How should a writer improve vocabulary?
- (iv) How did the world change during the last century according to Dr.Kalam?
- (v) Why did the clergyman join Scoresby in the war?
- (vi) What is the message of the fable that Gandhi referred?
- (vii) How does the author describe the future of humanity in the lesson 'The Dying Sun'?

[3+3+3+3+3+3+4]

PART-B

- 2.(a) Comment on L.A.Hills views on "The Principles of Good Writing".
- (b) How did Gopinath influence the airline industry? [8+8]
- 3.(a) What are the two accidents described by James Jeans? Describe them.
- (b) Mention Sudha Murthy's achievements. [8+8]
- 4.(a) Describe the participation of Scoresby in the war.
- (b) What was Naidu's relationship with agriculture? [8+8]
- 5.(a) How does science affect the opinions of an average man? Explain the views of Haldane.
- (b) What does India need to do to stay ahead in the global supercomputer race according to Dr.Bhatkar? [8+8]
- 6.(a) "But hence forward I became a student" What does Gandhi mean by saying so?
- (b) Write an essay on 'Misuse of Technology'. [8+8]

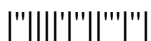

- 7.(a) Write the Synonyms for the following words.
- (i) genuine
 - (ii) endangered
 - (iii) frequent
 - (iv) prolonged
- (b) Write the Antonyms for the following words.
- (i) wild
 - (ii) mortal
 - (iii) truce
 - (iv) unsurpassed
- (c) Fill in the blanks with suitable Prepositions.
- (i) He always argues ----- the teacher.
 - (ii) The college is open -----9 A.m. to 5 P.M.
 - (iii) She is thirsty ----- knowledge.
 - (iv) They visited us -----June.
- (d) Correct and rewrite the following sentences.
- (i) I was at time for the presentation.
 - (ii) He returned back from Germany last year.
 - (iii) I am hearing the music.
 - (iv) He is a honorable man.

[4+4+4+4]



Subject Code: R13101/R13

Set No - 3

I B. Tech I Semester Regular Examinations Feb./Mar. - 2014

ENGLISH-I

(Common to All Branches)

Time: 3 hours

Max. Marks: 70

Question Paper Consists of **Part-A** and **Part-B**
Answering the question in **Part-A** is Compulsory,
Three Questions should be answered from **Part-B**

PART-A

- 1.(i) What are the areas that can help India change into a knowledge society?
- (ii) How is that a scientist is a curious mixture of pride and humility according to Haldane.
- (iii) How does James Jeans describe the vastness of the universe?
- (iv) Describe what Russell wants the Neutrals to do?
- (v) How did the clergyman feel when Scoresby was elected as the captain of marching regiment ?
- (vi) What efforts did Gandhi make to adapt himself to London lifestyle?
- (vii) Where can an author get the topics to write according to L.A.Hill?

[3+3+3+3+3+3+4]

PART-B

- 2.(a) What does a common man think about science? How does it differ from Haldane's opinion?
- (b) What was the defining moment of Naidu's life? [8+8]
- 3.(a) Why does James Jeans say that the sun is dying? How can physical science help us in such a situation?
- (b) How did Dr.Bhatkar help develop IT field in India? [8+8]
- 4.(a) "A writer should be a good reader and a keen observer"-Do you agree with L.A.Hills views? Give reasons.
- (b) What were the different fields Gopinath entered into? [8+8]
- 5.(a) Describe any of the blunders that you or any one you know has made, which actually helped the situation instead of spoiling it.
- (b) How was Infosys started? How did it change Sudha Murthy's life? [8+8]
- 6.(a) What problems are involved in making Abdul Kalam's dream come to reality?
- (b) Write an essay on 'The Role of Media in Education'. [8+8]



- 7.(a) Write the Synonyms for the following words.
- (i) eliminate
 - (ii) astonishment
 - (iii) peasant
 - (iv) swear
- (b) Write the Antonyms for the following words.
- (i) rare
 - (ii) depart
 - (iii) natural
 - (iv) vivid
- (c) Fill in the blanks with suitable Prepositions.
- (i) He is not responsible ----- this.
 - (ii) I have been living here ----- 1986.
 - (iii) The boy travels ----- bus
 - (iv) The principal congratulated the team ----- their success.
- (d) Correct and rewrite the following sentences.
- (i) He is a honest man.
 - (ii) We discussed about the matter.
 - (iii) Each of the boys get a prize.
 - (iv) They enjoyed the picnic very much.

[4+4+4+4]



Subject Code: R13101/R13

Set No - 4

I B. Tech I Semester Regular Examinations Feb./Mar. - 2014

ENGLISH-I

(Common to All Branches)

Time: 3 hours

Max. Marks: 70

Question Paper Consists of **Part-A** and **Part-B**
Answering the question in **Part-A** is Compulsory,
Three Questions should be answered from **Part-B**

PART-A

- 1.(i) How did the Earth come into existence according to James Jeans?
 - (ii) How much importance does the L.A.Hill give for inspiration to become a writer?
 - (iii) Why do you think Gandhi wants every youth to learn from him about saving money.
 - (iv) What does Haldane wants to tell us by giving the example of American Negroes.
 - (v) What is the problem that the Russell says is stark, dreadful and inescapable?
 - (vi) What and how are the blunders of Scoresby interpreted by others in the war?
 - (vii) What are the areas which can help India change into a knowledge super power?
- [3+3+3+3+3+3+4]

PART-B

- 2.(a) What according to Abdul Kalam should be done to generate wealth in India?
 - (b) Give an account of the work done by Sudha Murthy as a philanthropist.
- [8+8]
- 3.(a) Summarize the suggestions offered by Russell to nations as well as the general public for the maintenance of world peace?
 - (b) What did Naidu do with the motor cycle after the British surveyor gifted it to him? What were his other achievements?
- [8+8]
- 4.(a) Write about Scoresby's character.
 - (b) Give an account of the letter written by the headmaster to the ministry of defense in Delhi. How did that letter change the life of Gopinath?
- [8+8]
- 5.(a) What are the views expressed by Haldane about Science and its effects?
 - (b) What were the path breaking initiatives that Dr.Bhatkar led?
- [8+8]
- 6.(a) Comment on Hill's views about good writing and write about his suggestions for aspiring writers.
 - (b) Write an essay on 'Socialism'.
- [8+8]

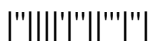

- 7.(a) Write the Synonyms for the following words.
- (i) humility
 - (ii) frequent
 - (iii) lynching
 - (iv) pursuit
- (b) Write the Antonyms for the following words.
- (i) orthodox
 - (ii) hastily
 - (iii) arbitrary
 - (iv) vivid
- (c) Fill in the blanks with suitable Prepositions.
- (i) The house is made -----wood.
 - (ii) He apologized ----- his behavior in the party.
 - (iii) This solution is not clear-----me
 - (iv) He is curious -----many things.
- (d) Correct and rewrite the following sentences.
- (i) The price of mangoes are high.
 - (ii) He went to school just now.
 - (iii) One must love his country.
 - (iv) John is an university student.

[4+4+4+4]



Subject Code : R10101/R10 (2012-13 Batch)

Set No - 1

I B.Tech I Semester Supplementary Examinations Feb./Mar. - 2014

ENGLISH – I

(Common to All Branches)

Time: 3 hours

Max. Marks : 75

**Answer any FIVE Questions
All Questions carry equal marks**

* * * * *

- 1.(a) What were the efforts made by 'Gandhi' to lead a simple Indian life in London?
(b) Give the synonyms for the following words:
(i) destiny (ii) nursery (iii) ruinous (iv) tedious (v) eradication [10+5]
- 2.(a) "There is more satisfaction in rational saving than an irrational spending." Substantiate this view of P.T.Barnum.
(b) Give the antonyms for the following words:
(i) suppress (ii) rivals (iii) cheerful (iv) benefit (v) aseptic [10+5]
- 3.(a) Sketch the character of Edward Middleton.
(b) Write about any one of the educational tours you went on during your school or college days. [10+5]
- 4.(a) Justify the title 'Three Days to See' by Helen Keller.
(b) Develop a dialogue between an employee and the Manager. The employee wants to go on leave for one week and the Manager refuses to grant the leave. The employee should try and convince the manager. [10+5]
- 5.(a) Write about the importance of Gender Equality.
(b) Fill in the blanks with suitable verb forms.
(i) She _____ mangoes (sell).
(ii) The teacher _____ a report last week (receive).
(iii) John _____ a car recently (purchase).
(iv) This building _____ to my brother (belong) .
(v) I _____ go to school tomorrow (be). [10+5]
- 6.(a) 'Coordination between the members of the team is essential for the smooth running of work'. Explain.
(b) Correct and rewrite the following sentences/questions.
(i) Are you having some money?
(ii) She work hard.
(iii) I need an information.
(iv) He and I am writing the exam.
(v) He returned back from London last year. [10+5]



- 7.(a) Expand the line below into a paragraph.
‘Wisdom is better than knowledge’
- (b) Rewrite the following sentences as directed.
- (i) He enjoyed very much (add a reflexive pronoun)
 - (ii) He lately realized that he is almost wrong (pick the adverbs)
 - (iii) He has bought a car last year (correct the tense)
 - (iv) Strength (write the verb form)
 - (v) He is a very clever boy (pick the adjective)

[10+5]

- 8.(a) Give one word substitute for the following
- (i) Short narrative conveying a moral _____
 - (ii) Make up for _____
 - (iii) Being unable to divide _____
 - (iv) The stage of development _____
 - (v) Determination to keep trying _____
- (b) Tick the right answer
- (i) He writes _____
(a) legibly (b) legably (c) lengthy (d) timely
 - (ii) Related to money, economy: _____
(a) Poverty (b) pecuniary (c) savings (d) spending
 - (iii) To behave in a superior manner to impress others is _____
(a) patronize (b) haughtily (c) beat the beech (d) pompous
 - (iv) university : college :: continent : _____
(a) state (b) country (c) nation (d) globe
 - (v) Recluse : Hermit :: friend : _____
(a) hostile (b) Rival (c) seclude (d) gregarious
- (c) What is a gerund? Explain with examples.

[5+5+5]



Subject Code : R10101/R10 (2012-13 Batch)

Set No - 2

I B.Tech I Semester Supplementary Examinations Feb./Mar. - 2014

ENGLISH – I

(Common to All Branches)

Time: 3 hours

Max. Marks : 75

Answer any FIVE Questions
All Questions carry equal marks

* * * * *

- 1.(a) Why did Gandhi want to take the task of becoming an English gentle man and why did he withdraw from pursuing that idea?
(b) Give the synonyms for the following
(i) dreary (ii) tryst (iii) earnest (iv) pecuniary (v) mend [10+5]
- 2.(a) What kind of people according to Barnum can attain pecuniary independence?
(b) Write the antonyms for the following words.
(i) irrational (ii) vanity (iii) unforeseen (iv) sluggish (v) cheerful [10+5]
- 3.(a) Narrate in your own words lawyer Gibb's offer to Middleton.
(b) Write about any of your travel experiences. [10+5]
- 4.(a) List Keller's visits to various places on her second seeing day.
(b) Write a dialogue between a teacher and a parent. The parent wants to know about his son's marks and attendance but the teacher is busy at that moment. [10+5]
- 5.(a) Write about journalism as a career for woman.
(b) Fill in the blanks with suitable verb forms.
(i) The president _____ at 9 a.m tomorrow. (arrive)
(ii) We ___ to move to the new house next week. (go)
(iii) She _ if you say sorry. (work)
(iv) She ___ to market yesterday. (go)
(v) I _____ here since morning. (wait) [10+5]
- 6.(a) Write about importance of 'Adaptability at work place'
(b) Correct and rewrite the following sentences.
(i) Where you are?
(ii) I have broke the glass.
(iii) She described about her project.
(iv) I am suffering with fever.
(v) I and Ram are friends. [10+5]

- 7.(a) Expand the saying into a paragraph. “An idle man’s brain is a devil’s workshop”.
- (b) Rewrite as directed.
- (i) Flexible (change to a noun)
 - (ii) He enjoyed very much (add a reflexive pronoun)
 - (iii) Miserable (use the word in your own sentence)
 - (iv) Adaptability (make an adjective)
 - (v) It rained heavily, severely and damaged the huts. (correct the order of adjectives)
- [10+5]
- 8.(a) Give one word substitutes for the following
- (i) Persons competing with each other.
 - (ii) A long narrative poem.
 - (iii) The crime of creating a false document.
 - (iv) One who hates mankind.
 - (v) Process for cooking a dish.
- (b) Tick the right answer.
- (i) coward : fear : : soldier: _____
(a) war (b) battle (c) courage (d)vanity
 - (ii) melancholy : sadness : : merriment : _____
(a) strength (b) joy (c) moody (d) cranky
 - (iii) Humility : arrogance : : impartial : _____
(a) biased (b) mean (c) jovial (d) ignorance
 - (iv) None of us found the movie _____
(a) black (b) reality (c) interesting (d) blind
 - (v) He is not only kind but also _____
(a) stand (b) illiterate (c)greedy (d) generous
- (c) Write about ‘to infinitive’ and give examples.
- [5+5+5]



Subject Code : R10101/R10 (2012-13 Batch)

Set No - 3

I B.Tech I Semester Supplementary Examinations Feb./Mar. - 2014

ENGLISH – I

(Common to All Branches)

Time: 3 hours

Max. Marks : 75

**Answer any FIVE Questions
All Questions carry equal marks**

*** * * * ***

- 1.(a) How did Gandhi realize that it was not necessary to imitate others? What changes did he make in his lifestyle as he realized this?
(b) Write the synonyms for the following words
(i) aseptic (ii) redeem (iii) recluse (iv) dormant (v) mend
[10+5]
- 2.(a) 'True economy consists in always making the income exceed the out- go' – Elaborate this view of P.T Barnum.
(b) Give the antonyms for the following words
(i) inevitable (ii) unforeseen (iii) modest (iv) voluntary (v) courage
[10+5]
- 3.(a) Who do you think is the man, of moral values, lawyer Gibbs or Edward Middleton? Give reasons.
(b) How does travelling to different places help us?
[10+5]
- 4.(a) Enumerate Keller's plans for her third and last day of vision.
(b) Write a dialogue between your area post-man and you when you inform him about your change of address.
[10+5]
- 5.(a) 'Discrimination against women is a social evil' - Discuss.
(b) Fill in the blanks with suitable verb forms
(i) John ___ violin. (play)
(ii) He _____ (come), if you _____ him. (invite)
(iii) It _____ to rain. (go)
(iv) I ___ him for a long time. (know)
[10+5]
- 6.(a) What are life skills? How are they different from communication skills?
(b) Correct the following sentences.
(i) My brother have two houses.
(ii) I and my friend attended the seminar.
(iii) Every one feel responsible.
(iv) They doesn't want to go with him.
(v) We discussed about the matter.
[10+5]



- 7.(a) 'It is the mind that makes heaven out of hell and hell out of heaven' - Explain the line in a paragraph.
- (b) Rewrite the following as directed.
- (i) Flexibility (change to Adjective)
 - (ii) Merry (form an adverb)
 - (iii) Conduct (make negative adding a prefix)
 - (iv) Loaf (write the plural form)
 - (v) I hurt..... (add a reflexive pronoun and make a sentence)

[10+5]

- 8.(a) Give one word substitutes for the following.
- (i) A feeling of well being_____
 - (ii) Area of knowledge _____
 - (iii) Long bench with back and sides _____
 - (iv) A mental view or vision _____
 - (v) One who eats too much _____
- (b) Tick the right answer
- (i) He writes _____
(a) legibly (b) legably (c) lengthy (d) timely
 - (ii) Related to freedom, and not depend ____
(a) dependence (b) independence (c) reliability (d) open
 - (iii) A stitch in time_____
(a) is good (b) saves nine (c) correct (d) wrong
 - (iv) university : college : : continent : _____
(a) State (b) country (c) nation (d) globe
 - (v) Recluse : Hermit : : friend : _____
(a) Hostile (b) Rival (c) seclude (d) gregarious
- (c) Write about the 'progressive form of the verb with examples.

[5+5+5]



Subject Code : R10101/R10 (2012-13 Batch)

Set No - 4

I B.Tech I Semester Supplementary Examinations Feb./Mar. - 2014

ENGLISH – I

(Common to All Branches)

Time: 3 hours

Max. Marks : 75

Answer any FIVE Questions
All Questions carry equal marks

* * * * *

- 1.(a) What are Gandhi's experiences as a student in London?
(b) Give the synonyms for the following words:
(i) utterance (ii) caution (iii) jaunt (iv) gusty (v) emulate [10+5]
- 2.(a) What are Barnum's suggestions for practicing economy?
(b) Write the Antonyms of the following words:
(i) independence (ii) courage (iii) mitigate (iv) minor (v) neglect [10+5]
- 3.(a) Who is the hero in the drama "The Drunkard" Lawyer Gibbs or Edward Middleton?
Give reasons.
(b) Write about any two important places you want to visit in India. [10+5]
- 4.(a) Summarise Hellen Keller's views about the importance of senses, particularly eyes.
(b) Write the conversation between a traffic police and you, while you are driving without proper license. The police charges you heavy fine but you do not have money. [10+5]
- 5.(a) Explain the problems with 'Dowry system'.
(b) Fill in the blanks with suitable verb forms.
(i) Birds _____ in the sky. (fly)
(ii) He _____ much better now. (feel)
(iii) If you _____ hard, you _____ pass the exam. (work,pass)
(iv) You _____ the exam by this time tomorrow. (complete) [10+5]
- 6.(a) How does non-verbal communication and attitude help a team leader? Explain.
(b) Correct and rewrite the following sentences.
(i) The pen or pencil are in the bag.
(ii) I and Hari worked on this project.
(iii) He worked hardly, so he passed the exam.
(iv) Each of the sisters are good at singing.
(v) She has seen the movie last week. [10+5]



- 7.(a) Expand the saying into a paragraph 'Too many cooks spoil the broth.'
(b) Rewrite as directed.
(i) Respect (add a prefix to make the opposite)
(ii) Usjbtec (correct the jumbled word)
(iii) Virtual (make an adverb)
(iv) The serene cold weather damaged the cotton fields. (pick the adjectives)
(v) He did it (add a reflexive pronoun)

[10+5]

- 8.(a) Give one word substitutes for the following:

- (i) A mental view or vision ____
(ii) A feeling of sadness ____
(iii) One who helps others ____
(iv) Being only one of its kind ____
(v) A study of races ____

- (b) Tick the right answer.

- (i) coward : fear : : soldier _____
(a) war (b) battle (c) courage (d)vanity
(ii) melancholy : sadness : : merriment : _____
(a) Strength (b) joy (c) moody (d) cranky
(iii) Humility : arrogance : : impartial : _____
(a) Biased (b) mean (c) jovial (d) ignorance
(iv) None of us found the claims _____ to believe.
(a) genuine (b) false (c) vague (d) wrong
(v) He is not only kind but also _____
(a) stand (b) illiterate (c)greedy (d) generous

- (c) Write about simple present tense with examples.

[5+5+5]



ENGLISH – I

(Common to All Branches)

Time: 3 hours

Max. Marks : 75

Answer any FIVE Questions
All Questions carry equal marks

* * * * *

- 1.(a) What is the importance of the quality “Reliability” for a team member? Explain with examples.
(b) Write the Synonyms for the following words:
(i) academic (ii) quest (iii) destiny (iv) heritage (v) vicious [10+5]
- 2.(a) ‘ Problem Solving’ and Decision Making are important qualities of a team leader. Elaborate.
(b) Write the antonyms for the following words.
(i) exclusive (ii) misery (iii) rivals (iv) minor (v) inalienable [10+5]
- 3.(a) What are the important places that you would like to visit in India?
(b) What steps do you suggest to go on a long trip to a distant place? [10+5]
- 4.(a) ‘Write a dialogue between you and your neighbor about the colony committee meeting and the issues to be discussed there.
(b) Invite your friend to attend your convocation ceremony. Write a telephone conversation. [10+5]
- 5.(a) Write an essay on ‘Gender Bias’
(b) Fill the blanks with suitable verb forms.
(i) He ----- a football player. (be)
(ii) Sita ----- the movie last week. (see)
(iii) I ----- TV when the postman ----- the parcel. (watch,bring)
(iv) It ----- since morning. (rain) [10+5]
- 6.(a) Suggest some measures to improve your “learning skills.
(b) Correct and rewrite the following sentences:
(i) Ten miles are a long distance.
(ii) She prefers coffee than tea.
(iii) Either Rose or Lily get the chance to participate in the concert.
(iv) They enjoyed the picnic very much.
(v) He ran fastly. [10+5]
- 7.(a) Expand the saying into a paragraph- ‘As you sow, so shall you reap.’
(b) Rewrite as directed
(i) Manage (Change the verb into adjective)
(ii) Slowly and steadily she rose to a high position (pick the adverbs)
(iii) Emeder(Correct the spelling)
(iv) Leaf(write the plural form)
(v) What your name is?(Correct the word order) [10+5]



- 8.(a) Write one word substitute for the following:
- (i) To meet with _____
 - (ii) Only one of its kind _____
 - (iii) One who is stingy about money _____
 - (iv) A meeting for exchange of information _____
 - (v) To occupy something forcibly _____
- (b) Tick the right answer
- (i) blemish : fault :: flaw :
(a) error (b) recur (c) blame (d) fancy
 - (ii) ignite : extinguish : harvest : _____
(a) plant (b) rest (c) trust (d) remove
 - (iii) Cluster: group :: bunch :
(a) fruits (b) huddle (c) grapes (d) houses
 - (iv) release : arrest :: convict :
(a) set (b) exile (c) acquit (d) hang
 - (v) hasty : patience :: unqualified : _____
(a) skilled (b) logic (c) credentials (d) gullible
- (c) Write about 'to infinitive'. Give three examples.

[5+5+5]



ENGLISH – I

(Common to All Branches)

Time: 3 hours

Max. Marks : 75

Answer any FIVE Questions
All Questions carry equal marks

* * * * *

- 1.(a) Explain the importance of English language communication skills for professionals.
(b) Write the Synonyms for the following words.
(i) release (ii) palpable (iii) remnant (iv) academic (v) exploitative [10+5]
- 2.(a) What are the characteristics of a good team work?
(b) Write the antonyms for the following words.
(i) mend (ii) voluntary (iii) infest (iv) inevitable (v) reject [10+5]
- 3.(a) Describe your trip to a museum or a dam.
(b) Write about the advantages of tourism. [10+5]
- 4.(a) Write a dialogue between two employees about the new products released by their company, their benefits to the consumers, competitors and likely profits to the company.
(b) Develop a dialogue between you and a shop keeper. Ask for the details of the goods available in his shop comparing the prices of various companies. [10+5]
- 5.(a) Write an essay on the 'Evils of Dowry System'.
(b) Fill in the blanks with suitable verb forms.
(i) I ----- a letter next week to my teacher. (write)
(ii) He ----- green tea every morning.(drink)
(iii) The boy----- while it ----- raining.(play, rain)
(iv) She ----- for the bus since morning.(wait) [10+5]
- 6.(a) Explain the importance of creativity and problem solving skills for an Engineer.
(b) Correct and rewrite the following sentences.
(i) Ram went to temple every Monday.
(ii) Each of the boys have to pay the fees by next Tuesday.
(iii) I gave him the key just now.
(iv) Where you are?
(v) He lost his purse. Isn't it? [10+5]
- 7.(a) Expand this saying into a paragraph- 'Old is gold'.
(b) Rewrite as directed.
(i) Courage (Change the noun into adjective)
(ii) Regular (Write the adverb form)
(iii) Nuohor (Correct the spelling)
(iv) Medium (write the plural form)
(v) The cool and dry climate is pleasant.(pick the adjectives) [10+5]



- 8.(a) Give one word substitutes for the following.
- (i) A long narrative poem _____
 - (ii) To move around in a circular motion _____
 - (iii) A place where birds are kept _____
 - (iv) An area where wild life is preserved _____
 - (v) A person who can speak many languages _____
- (b) Tick the right answer.
- (i) greed : generous :: miser: _____
(a) clumsy (b) fury (c) mean (d) spendthrift
 - (ii) epic : fable :: classic ::
(a) theme (b) tale (c) book (d) play
 - (iii) locker: storage :: telephone : _____
(a) communication (b) cash (c) bill (d) mobile
 - (iv) elderly : youth :: healthy : _____
(a) famous (b) rational (c) smug (d) illness
 - (v) hidden : visible :: flimsy :
(a) delicious (b) sturdy (c) classy (d) edible
- (c) What is a gerund? Give three examples.

[5+5+5]



ENGLISH – I

(Common to All Branches)

Time: 3 hours

Max. Marks : 75

Answer any FIVE Questions
All Questions carry equal marks

* * * * *

- 1.(a) 'Positive attitude results in Problem Solving and happy living' Analyze.
(b) Give the Synonyms for the following words:
(i) pledge (ii) misery (iii) vicious (iv) puberty (v) commitment [10+5]
- 2.(a) What do you think are the good qualities you need to develop to become a good member of the team?
(b) Write the antonyms for the following words:
(i) rival (ii) rational (iii) manufacture (iv) inevitable (v) serene [10+5]
- 3.(a) Give the details of your recent pleasure trip with your friends or family members.
(b) Suggest the safety measures when someone visits new places. [10+5]
- 4.(a) You have an argument with your neighbor when the latter parked his vehicles in front of your house. He tries to convince you but you are stubborn.
(b) Your manager refused to grant you leave for a pleasure trip with your family. Convince him with the reasons. Write in the form of a dialogue. [10+5]
- 5.(a) 'Angels tread where women is respected' Elaborate.
(b) Fill in the blanks with suitable verb forms.
(i) I ----- the doctor tonight. (meet)
(ii) He ----- better after the treatment. (feel)
(iii) The govt -----him the Best teacher award last year. (give)
(iv) The train ----- , before my friend ----- the station. (leave, reach) [10+5]
- 6.(a) 'Adaptability is an essential quality to achieve team goals.' Explain.
(b) Correct and rewrite the following sentences/questions.
(i) He enjoyed the picnic.
(ii) Did he gone there?
(iii) He is working hardly for his exams.
(iv) It is raining, wasn't it?
(v) Ram and myself are attending the meeting. [10+5]
- 7.(a) Expand the saying into a paragraph- 'Empty vessels make more noise'
(b) Rewrite as directed
(i) Valuable(Change the noun into adjective)
(ii) Secret (Write the adverb form)
(iii) Lnolye(Correct the spelling)
(iv) Alumnus (write the plural form)
(v) You must others respect(Correct the word order) [10+5]



- 8.(a) Give one word substitutes.
- (i) The stage of development _____
 - (ii) A person who starts any movement or change in the system _____
 - (iii) The conventions of a particular social group _____
 - (iv) One who loves man kind _____
 - (v) One who is fond of food _____
- (b) Tick the right answer
- (i) Anger : frustration:: serenity :-----
(a) despair (b) wrath (c) satisfaction (d) misery
 - (ii) elderly : youth :: healthy : _____
(a) famous (b) rational (c) smug (d) illness
 - (iii) suburb : outskirts :: city :
(a) rural (b) urban (c) village (d) dense
 - (iv) Seismograph : Earthquake :: thermometer :-----
(a) health (b) abacus (c) stethoscope (d) temperature
 - (v) Shard : Glass :: scrap :-----
(a) morsel (b) quilt (c) wood (d) rope
- (c) Write about progressive verb form and give 3 examples.

[5+5+5]



ENGLISH – I

(Common to All Branches)

Time: 3 hours

Max. Marks : 75

Answer any FIVE Questions
All Questions carry equal marks

* * * * *

- 1.(a) Write about the importance of transparency and good communication for team work.
(b) Write the Synonyms for the following words:
(i) redeem (ii) paranoia (iii) solemn (iv) transmit (v) trust [10+5]
- 2.(a) 'Reliability and commitment make one a successful person' Elucidate.
(b) Write the antonyms for the following words.
(i) vulnerable (ii) summit (iii) rivals (iv) aseptic (v) voluntary [10+5]
- 3.(a) What are the important tourist/religious places that you would like to visit in your life?
Explain their importance.
(b) Suggest some steps to ensure safety of tourists in India. [10+5]
- 4.(a) You have to make arrangements for your sister's wedding. Write a dialogue on the discussion with your father.
(b) Explain to your mother the reason for your coming late in the night. Write a telephonic conversation when your mother is upset with your late coming. [10+5]
- 5.(a) Explain your views on "Women Empowerment".
(b) Fill in the blanks with suitable verb forms.
(i) She----- tea. (like)
(ii) Either of the sisters ----- good at singing. (be)
(iii) I ----- the conference (attend), if they ----- me.(invite)
(iv) She is----- noise. (hear) [10+5]
- 6.(a) Write an essay on Adaptability and problem solving skills.
(b) Correct and rewrite the following sentences.
(i) Birds flies in the air.
(ii) He has gone to market last Sunday.
(iii) Every boy and girl have a bag.
(iv) The price of vegetables are high these days.
(v) I enjoyed the dinner. [10+5]
- 7.(a) Expand the saying into a paragraph- 'To err is human; To forgive is divine'
(b) Rewrite as directed
(i) Loyalty(Change the noun into adjective)
(ii) Wild (Write the adverb form)
(iii) Jetcer (Correct the spelling)
(iv) Child(write the plural form)
(v) It rained last heavily night (Correct the word order) [10+5]

- 8.(a) Give one word substitutes.
- (i) One who collects stamps _____
 - (ii) Study of birds _____
 - (iii) An area where wild life is preserved _____
 - (iv) A binding promise or agreement _____
 - (v) Love for mankind _____
- (b) Tick the right answer.
- (i) Novel : Book :: epic : -----
(a) poem (b) fable (c) tale (d) play
 - (ii) Beauty : admire :: food :
(a) depressed (b) fury (c) relish (d) foolish.
 - (iii) Realistic : Quixotic :: tormentor : -----
(a) lethargic (b) scholar (c) sympathetic (d) pedantic
 - (iv) hidden : visible :: flimsy :
(a) delicious (b) sturdy (c) classy (d) edible
 - (v) Hard : easy :: rigid :
(a) flexible (b) rough (c) solid (d) rocky
- (c) Write about simple present tense with examples.

[5+5+5]



MATHEMATICS-I

(Common to All Branches)

Time: 3 hours**Max. Marks: 70**

Question Paper Consists of **Part-A** and **Part-B**
 Answering the question in **Part-A** is Compulsory,
 Three Questions should be answered from **Part-B**

PART-A

- 1.(i) Find the orthogonal trajectories of the curve $r = a(1 + \cos \theta)$.
- (ii) If $x = r \sin \theta \cos \phi$, $y = r \sin \theta \sin \phi$, $z = r \cos \theta$, find $\frac{\partial(r, \theta, \phi)}{\partial(x, y, z)}$, given that $\frac{\partial(x, y, z)}{\partial(r, \theta, \phi)} = r^2 \sin \theta$.
- (iii) Find the Laplace transform of $f(t) = \begin{cases} t, & 0 < t < 1 \\ 0, & t > 1 \end{cases}$ using Heaviside function.
- (iv) Let the heat conduction in a thin metallic bar of length L is governed by the equation $\frac{\partial u}{\partial t} = a^2 \frac{\partial^2 u}{\partial x^2}$, $t > 0$. If both ends of the bar are held at constant temperature zero and the bar is initially has temperature $f(x)$, find the temperature $u(x, t)$.
- (v) Solve $p^2 + pq = z^2$.
- (vi) Find $\frac{1}{D^2 - 4D + 4} x^2 \sin x$. [4+4+4+4+3+3]

PART- B

- 2.(a) Solve $y(2x^2 - xy + 1)dx + (x - y)dy = 0$
- (b) Find the complete solution of $y'' + 2y = x^2 e^{3x} + e^x \cos 2x$ [8+8]
- 3.(a) Solve $\frac{dy}{dx} + x \sin 2y = x^3 \cos^2 y$
- (b) Find the solution of $\frac{d^2 y}{dx^2} + 4y = \sin 3x + \cos 2x$. [8+8]
- 4.(a) Find the Laplace transform of $f(t) = \frac{\cos at - \cos bt}{t}$.
- (b) If $x = \sqrt{vw}$, $y = \sqrt{uw}$, $z = \sqrt{uv}$ and $u = r \sin \theta \cos \phi$, $v = r \sin \theta \sin \phi$ and $w = r \cos \theta$, find $\frac{\partial(x, y, z)}{\partial(r, \theta, \phi)}$. [8+8]
- 5.(a) Expand $f(x, y) = e^y \ln(1 + x)$ in powers of x and y using MacLaurin's Series
- (b) Solve $y'' - 8y' + 15y = 9te^{2t}$, $y(0) = 5$ and $y'(0) = 10$ using Laplace transforms [8+8]
- 6.(a) Solve $(y + xz)p - (x + yz)q = x^2 - y^2$.
- (b) Solve the partial differential equation $px + qy = 1$. [8+8]
- 7.(a) Find the partial differential equation of all spheres whose centers lie on z- axis.
- (b) Find the solution of the wave equation $\frac{\partial^2 u}{\partial t^2} = a^2 \frac{\partial^2 u}{\partial x^2}$, if the initial deflection is $f(x) = \begin{cases} \frac{2k}{l}x & \text{if } 0 < x < l/2 \\ \frac{2k}{l}(l - x) & \text{if } \frac{l}{2} < x < l \end{cases}$ and initial velocity equal to 0. [8+8]



MATHEMATICS-I

(Common to All Branches)

Time: 3 hours**Max. Marks: 70**

Question Paper Consists of **Part-A** and **Part-B**
 Answering the question in **Part-A** is Compulsory,
 Three Questions should be answered from **Part-B**

PART-A

- 1.(i) Find the complete solution of $(D^4 + 16)y = 0$.
- (ii) If $x = r\cos\theta, y = r\sin\theta, z = z$, find $\frac{\partial(r,\theta,z)}{\partial(x,y,z)}$, given that $\frac{\partial(x,y,z)}{\partial(r,\theta,z)} = r$.
- (iii) Solve $x^2p^2 + y^2q^2 = z^2$.
- (iv) Find the solution, by Laplace transform method, of the integro-differential equation

$$y' + 3y + 2 \int_0^t y(t)dt = t$$
- (v) Find the differential equation of the orthogonal trajectories for the family of parabola through the origin and foci on y-axis.
- (vi) Find the solution of wave equation in one dimension using the method of separation of variables.

[3+3+4+4+4+4]

PART-B

- 2.(a) Solve $y(y^2 - 2x^2)dx + x(2y^2 - x^2)dy = 0$
- (b) Find the complete solution of $y'' + 5y' - 6y = \sin 4x \sin x$. [8+8]
- 3.(a) Solve $\cos x dy = y(\sin x - y)dx$.
- (b) Find the solution of $\frac{d^2y}{dx^2} - 4\frac{dy}{dx} + 3y = 2xe^{3x} + 3e^x \cos 2x$. [8+8]
- 4.(a) Find the Laplace transform of $f(t) = \int_0^t e^{-u} \cos u du$.
- (b) Find the shortest distance from origin to the surface $xyz^2 = 2$. [8+8]
- 5.(a) Find $\frac{\partial(u,v)}{\partial(r,\theta)}$ if $u = 2axy$ and $v = a(x^2 - y^2)$, where $x = r\cos\theta$ and $y = r\sin\theta$.
- (b) Solve $y'' - 8y' + 15y = 9te^{2t}$, $y(0) = 5$ and $y'(0) = 10$ using Laplace transforms [8+8]
- 6.(a) Form the partial differential equation by eliminating the arbitrary function from $xyz = f(x + y + z)$.
- (b) Find the solution of $(D^2 - DD' - 2D'^2)z = (y - 1)e^x$, where $D = \frac{\partial}{\partial x}$ and $D' = \frac{\partial}{\partial y}$. [8+8]
- 7.(a) Solve the partial differential equation $xzp + yzq = xy$.
- (b) Find the temperature in a bar of length l which is perfectly insulated laterally and whose ends O and A are kept at 0°C , given that the initial temperature at any point P of the rod is given by f(x). [8+8]



MATHEMATICS-I

(Common to All Branches)

Time: 3 hours**Max. Marks: 70**

Question Paper Consists of **Part-A** and **Part-B**
 Answering the question in **Part-A** is Compulsory,
 Three Questions should be answered from **Part-B**

PART-A

- 1.(i) Find the dimensions of rectangular box of maximum capacity whose surface area is S.
- (ii) Find the orthogonal trajectories of the family of curves $x^{2/3} + y^{2/3} = a^{2/3}$.
- (iii) A generator having emf 100 volts is connected in series with a 10 ohm resistor and an inductor of 2 henries. If the switch is closed at a time $t=0$, find the current at time $t>0$.
- (iv) Find the Laplace transform of $f(t) = \begin{cases} t, & 0 < t < 1 \\ 0, & t > 1 \end{cases}$ using Heaviside function.
- (v) Solve $pq+qx = y$.
- (vi) Find the solution of $2x \frac{\partial z}{\partial x} - 3y \frac{\partial z}{\partial y} = 0$ by the method of separation of variables.

[4+4+4+4+3+3]

PART- B

- 2.(a) Solve $y(1 + xy)dx + x(1 - xy)dy = 0$
- (b) Find the complete solution of $y'' + 4y = e^x \sin^2 x$. [8+8]
- 3.(a) Solve $2x y' + y = \frac{2x^2}{y^3}, y(1) = 2$.
- (b) Find the solution of $\frac{d^2 y}{dx^2} - 4 \frac{dy}{dx} - 5y = e^{2x} + 3 \cos(4x + 3)$. [8+8]
- 4.(a) Find the Laplace transform of $f(t) = te^{-2t} \cos t$.
- (b) Find the maxima and minima of $x^3 + 3xy^2 - 15x^2 - 15y^2 + 72x$. [8+8]
- 5.(a) Expand $f(x, y) = e^{xy}$ in powers of $(x-1)$ and $(y-1)$.
- (b) Solve $y'' + 7y' + 10y = 4e^{-3t}, y(0) = 0$ and $y'(0) = -1$ using Laplace transforms. [8+8]
- 6.(a) Form the partial differential equation by eliminating the arbitrary constants 'a' and 'b' from $2z = \frac{x^2}{a^2} + \frac{y^2}{b^2}$.
- (b) Find the solution of $(4D^2 + 12DD' + 9D'^2)z = e^{3x-2y}$, where $D = \frac{\partial}{\partial x}$ and $D' = \frac{\partial}{\partial y}$. [8+8]
- 7.(a) Solve the partial differential equation $p \tan x + q \tan y = \tan z$.
- (b) A tightly stretched string with fixed end points $x=0$ and $x=l$ is initially in a position given by $y = y_0 \sin^3 \frac{\pi x}{l}$. If it is released from rest from this position, find the displacement $y(x, t)$. [8+8]



MATHEMATICS-I

(Common to All Branches)

Time: 3 hours**Max. Marks: 70**

Question Paper Consists of **Part-A** and **Part-B**
 Answering the question in **Part-A** is Compulsory,
 Three Questions should be answered from **Part-B**

PART-A

- 1.(i) Find the distance from the centre at which the velocity in simple harmonic motion will be 1/3rd of the maximum.
- (ii) Find a point within a triangle such that the sum of the squares of its distances from the three vertices is minimum.
- (iii) Find the solution, by Laplace transform method, of the integro-differential equation $y' + 4y = \int_0^t y(t)dt$, $y(0) = 0$.
- (iv) Uranium disintegrates at a rate proportional to the amount present at that time. If M and N grams of Uranium are present at times T_1 and T_2 respectively, find the half life of Uranium.
- (v) Find the complete solution of $(D^3 - 3D^2 D' + 3 DD'^2 - D'^3)z = 0$.
- (vi) Solve $z^2 = 1 + p^2 + q^2$.

[4+4+4+4+3+3]

PART-B

- 2.(a) Solve $(3y^2 + 4xy - x)dx + x(x + 2y)dy = 0$
- (b) Find the solution of $\frac{d^2y}{dx^2} + 5\frac{dy}{dx} - 6y = \sin 4x \cos x$. [8+8]
- 3.(a) Find the complete solution of $y'' + 2y = x^2 e^{3x} + e^x \cos 2x$.
- (b) Solve $xz' + z \log z = z(\log z)^2$. [8+8]
- 4.(a) Find the Laplace transform of $f(t) = te^{2t} \cos 2t$.
- (b) If $u = \sin^{-1}\left(\frac{x^3+y^3}{\sqrt{x}+\sqrt{y}}\right)$, prove that $xu_x + yu_y = \frac{5}{2} \tan u$. [8+8]
- 5.(a) If $w = (y - z)(z - x)(x - y)$, find the value of $\frac{\partial w}{\partial x} + \frac{\partial w}{\partial y} + \frac{\partial w}{\partial z}$.
- (b) Solve $y'' + 2y' + 5y = e^{-t} \sin t$, $y(0) = 0$ and $y'(0) = 1$ using Laplace transforms. [8+8]
- 6.(a) Form the partial differential equation by eliminating the arbitrary constants 'a' and 'b' from $z = ax + by + a^2 + b^2$.
- (b) Using method of separation of variables, solve $u_{xt} = e^{-t} \cos x$ with $u(x, 0) = u(0, t) = 0$. [8+8]
- 7.(a) Find the temperature in a thin metal rod of length L, with both ends insulated and with initial temperature in the rod is $\sin\left(\frac{\pi x}{L}\right)$.
- (b) Solve the partial differential equation $px^2 + qy^2 = z^2$. [8+8]



**I B.Tech I Semester Supplementary Examinations, Feb/Mar 2014
MATHEMATICS-I**(Common to Civil Engineering, Electrical & Electronics Engineering,
Mechanical Engineering, Electronics & Communication Engineering,
Computer Science & Engineering, Chemical Engineering, Electronics &
Instrumentation Engineering, Bio-Medical Engineering, Information
Technology, Electronics & Computer Engineering, Aeronautical
Engineering, Bio-Technology, Automobile Engineering, Mining and
Petroleum Technology)

Time: 3 hours

Max Marks: 75

Answer any FIVE Questions
All Questions carry equal marks

1. (a) Solve $(x^2 + y^2 - a^2)x dx + (x^2 - y^2 - b^2)y dy = 0$. [7+8]
(b) If air is maintained at $20^{\circ}C$ and the temperature of the body cools from $80^{\circ}C$ to $60^{\circ}C$ in 10 minutes, find the temperature of the body after 30 minutes.
2. (a) Solve $(D^2 + a^2)y = Sec ax$
(b) Solve $(D^2 + 4)y = e^x + Sin 2x$ [8+7]
3. (a) If $V = \log(x^2 + y^2) + x - 2y$ find $\frac{\partial V}{\partial x}, \frac{\partial V}{\partial y}, \frac{\partial^2 V}{\partial x^2}, \frac{\partial^2 V}{\partial y^2}$.
(b) If $U = xe^{xy}$ where $x^2 + y^2 + 2xy = 1$, find $\frac{\partial^2 U}{\partial x^2}$. [8+7]
4. (a) Trace the curve $r = 2 + 3 \sin \theta$.
(b) Trace the curve $y^2(2a - x) = x^3$. [8+7]
5. (a) Find the surface of the solid generated by revolution of the lemniscate $r^2 = a^2 \cos^2 \theta$ about the initial line.
(b) Show that the whole length of the curve $x^2(a^2 - x^2) = 8a^2y^2$ is $\pi a\sqrt{2}$. [8+7]
6. (a) Show that $\int_0^{4a} \int_{\frac{y^2}{4a}}^y \frac{x^2 - y^2}{x^2 + y^2} dx dy = 8a^2 \left(\frac{\pi}{2} - \frac{5}{3} \right)$.
(b) Evaluate $\iint_R y dx dy$ where R is the domain bounded by y-axis, the curve $y = x^2$ and the line $x + y = 2$ in the first quadrants. [8+7]
7. (a) If $V = e^{xyz}(i+j+k)$, find curl V.
(b) Find the constants a and b so that the surface $ax^2 - byz = (a+2)x$ will be orthogonal to the surface $4x^2y + z^3 = 4$ at the point (1,-1,2) [8+7]
8. (a) Show that the area of the ellipse $x^2/a^2 + y^2/b^2 = 1$ is πab
(b) If $f = (2x^2 - 3z)i - 2xyj - 4xzk$, evaluate
(i) $\int_v \nabla \cdot f dV$ and
(ii) $\int_v \nabla \times f dV$ where V is the closed region bounded by $x = 0, y = 0, z = 0, 2x + 2y + z = 4$. [8+7]



**I B.Tech I Semester Supplementary Examinations, Feb/Mar 2014
MATHEMATICS-I**

(Common to Civil Engineering, Electrical & Electronics Engineering,
Mechanical Engineering, Electronics & Communication Engineering,
Computer Science & Engineering, Chemical Engineering, Electronics &
Instrumentation Engineering, Bio-Medical Engineering, Information
Technology, Electronics & Computer Engineering, Aeronautical
Engineering, Bio-Technology, Automobile Engineering, Mining and
Petroleum Technology)

Time: 3 hours

Max Marks: 75

Answer any FIVE Questions
All Questions carry equal marks

1. (a) Solve $e^y \left(1 + \frac{dy}{dx}\right) = e^x$
 (b) Show that the family of curves $\frac{x^2}{a^2+\lambda} + \frac{y^2}{a^2-\lambda} = 1$, where ' λ ' is a parameter is self orthogonal. [8+7]
2. (a) Solve $(D^2 + 9)y = 2 \cos^2 x$. (b) Solve $\frac{d^2y}{dx^2} + 4y = 2e^x \sin^2 x$. [8+7]
3. (a) Calculate the approximate value of $\sqrt{10}$ to four decimal places using Taylor's theorem.
 (b) Find 3 positive numbers whose sum is 600 and whose product is maximum. [8+7]
4. (a) Trace the curve $y = x^2(x^2 - 4)$. (b) Trace the curve $r = \cos \theta$. [8+7]
5. (a) The figure bounded by a parabola and the tangents at the extremities of its latusrectum revolves about the axis of the parabola, Find the volume of the solid thus generated. [8+7]
 (b) The segment of the parabola $y^2 = 4ax$ which is cutoff by the latus rectum revolves about the directrix. Find the volume of rotation of the annular region.
6. (a) Evaluate $\int \int (x+y)^2 dx dy$ over the area bounded by the ellipse $\frac{x^2}{a^2} + \frac{y^2}{b^2} = 1$.
 (b) Transform the following to Cartesian form and hence evaluate $\int_0^\pi \int_0^a r^3 \sin \theta dr d\theta$. [8+7]
7. (a) Prove that $\nabla r = \bar{r}/r$
 (b) Find the angle between the surfaces $x^2 + y^2 + z^2 = 9$ and $z = x^2 + y^2 - 3$ at the point (2,-1,2). [8+7]
8. (a) Evaluate $\iint_S (yzi + zxj + xyk) \cdot dS$ where S is the surface of the sphere $x^2 + y^2 + z^2 = a^2$ in the first octant.
 (b) Evaluate $\oint_C (x^2 - 2xy)dx + (x^2y + 3)dy$ around the boundary of the region defined by $y^2 = 8x$ and $x = 2$. [8+7]

**I B.Tech I Semester Supplementary Examinations, Feb/Mar 2014
MATHEMATICS-I**

(Common to Civil Engineering, Electrical & Electronics Engineering,
Mechanical Engineering, Electronics & Communication Engineering,
Computer Science & Engineering, Chemical Engineering, Electronics &
Instrumentation Engineering, Bio-Medical Engineering, Information
Technology, Electronics & Computer Engineering, Aeronautical
Engineering, Bio-Technology, Automobile Engineering, Mining and
Petroleum Technology)

Time: 3 hours

Max Marks: 75

Answer any FIVE Questions
All Questions carry equal marks

1. (a) Solve $y(\sin x - y) dx = \cos x dy$
(b) If the temperature of air is maintained at $20^{\circ}C$ and the temperature of the body cools from $100^{\circ}C$ to $80^{\circ}C$ in 10 minutes, find the temperature of the body after 20 minutes. [8+7]
2. (a) Solve $(D^2 - 4D + 13)y = e^{2x}$
(b) Solve $(D^2 - 3D + 2)y = \cos hx$ [8+7]
3. (a) If $r + s + t = x$, $s + t = xy$, $t = xyz$, find $\frac{\partial(r,s,t)}{\partial(x,y,z)}$.
(b) Find the extreme points of $f(x, y) = xy + \frac{8}{x} + \frac{8}{y}$. [8+7]
4. (a) Trace the curve $y = 5 \cosh\left(\frac{x}{5}\right)$.
(b) Trace the curve $y^2 = (4 - x)(3 - x^2)$.. [8+7]
5. (a) Find the length of the arc of the curve $y = \log(\sec x)$ from $x = 0$ to $\frac{\pi}{3}$.
(b) Find the perimeter of the loop of the curve $3ay^2 = x(x-a)^2$. [8+7]
6. (a) Evaluate $\int \int r dr d\theta$ over the region bounded by the cardioid $r = a(1 + \cos\theta)$ and outside the circle $r = a$.
(b) Change the order of Integration & evaluate $\int_0^{4a} \int_{\frac{x^2}{4a}}^{2\sqrt{ax}} dy dx$ [8+7]
7. (a) Prove that $(\mathbf{F} \times \nabla) \times \mathbf{r} = -2\mathbf{F}$
(b) Determine the constant a so that the vector $\mathbf{V} = (x+3y)\mathbf{i} + (y-z)\mathbf{j} + (x+az)\mathbf{k}$ is solenoidal. [8+7]
8. Apply Stokes theorem, to evaluate $\oint_C y dx + z dy + x dz$ where C is the curve of intersection of the sphere $x^2 + y^2 + z^2 = a^2$ and $x + z = a$. [15]

**I B.Tech I Semester Supplementary Examinations, Feb/Mar 2014
MATHEMATICS-I**

(Common to Civil Engineering, Electrical & Electronics Engineering,
Mechanical Engineering, Electronics & Communication Engineering,
Computer Science & Engineering, Chemical Engineering, Electronics &
Instrumentation Engineering, Bio-Medical Engineering, Information
Technology, Electronics & Computer Engineering, Aeronautical
Engineering, Bio-Technology, Automobile Engineering, Mining and
Petroleum Technology)

Time: 3 hours

Max Marks: 75

Answer any FIVE Questions
All Questions carry equal marks

1. (a) Solve $(x + 1) \frac{dy}{dx} - y = e^{3x} (x + 1)^2$
 (b) Find the orthogonal trajectory of the family of curves $x^{2/3} + y^{2/3} = a^{2/3}$, where 'a' is a parameter [8+7]
2. (a) Solve $(D^3 - 6D^2 + 11D - 6)y = e^{-2x} + e^{-3x}$
 (b) Solve $\frac{d^2y}{dx^2} - 8 \frac{dy}{dx} + 15y = 0$ [8+7]
3. (a) If $a = \frac{yz}{x}$, $b = \frac{xz}{y}$, $c = \frac{xy}{z}$, find $\frac{\partial(x,y,z)}{\partial(a,b,c)}$.
 (b) Find the minimum value of $x^2 + y^2 + z^2$, give that $xyz = a^3$ [8+7]
4. (a) Trace the curve $r = \cos 4\theta$.
 (b) Trace the curve $y^2(1 - x) = x^2(1 + x)$. [8+7]
5. Prove that the volume of the solid generated by the revolution about the x -axis of the loop of the curve $x = t^2$, $y = t - \frac{1}{3}t^3$ is $\frac{3\pi}{4}$. [8+7]
6. (a) By changing the order of integration evaluate $\int_0^1 \int_0^{\sqrt{2-x^2}} \frac{x}{x^2 + y^2} dy dx$.
 (b) Evaluate $\int_0^a \int_{a-x}^{\sqrt{a^2-x^2}} y \, dx \, dy$ by using change of order of integration. [8+7]
7. (a) If $V = e^{xyz}(i+j+k)$, find curl V .
 (b) Find the constants a and b so that the surface $ax^2 - byz = (a+2)x$ will be orthogonal to the surface $4x^2y + z^3 = 4$ at the point $(1, -1, 2)$ [8+7]
8. (a) Use divergence theorem to evaluate $\iint_S (x^3i + y^3j + z^3k) \cdot N ds$, and S is the surface of the sphere $x^2 + y^2 + z^2 = r^2$.
 (b) Using Green's theorem, Find the area bounded by the hypocycloid $x^{2/3} + y^{2/3} = a^{2/3}$, $a > 0$. Given that the parametric equations are $x = a \cos^3\theta$, $y = a \sin^3\theta$. [8+7]

Subject Code: R13103/R13

Set No - 1

I B. Tech I Semester Regular Examinations Feb./Mar. - 2014

ENGINEERING PHYSICS

(Common to ECE, EEE, EIE, Bio-Tech, EComE, Agri.E)

Time: 3 hours

Max. Marks: 70

Question Paper Consists of **Part-A** and **Part-B**
Answering the question in **Part-A** is Compulsory,
Three Questions should be answered from **Part-B**

PART-A

- 1.(i) What are the necessary conditions for obtaining interference fringes?
- (ii) Explain the characteristic of laser.
- (iii) What are polar and non-polar dielectrics?
- (iv) Explain the terms 'Reverberation' and 'Reverberation time'.
- (v) Explain the salient features of Classical free electron theory?
- (vi) Explain the electronic transport mechanism for Photo Conductors.

[3+4+4+3+4+4]

PART-B

- 2.(a) What is meant by Diffraction of light? Explain it on the basis of Huygen's wave theory.
 - (b) Derive expressions for Acceptance angle and Numerical Aperture of an Optical fiber.
 - (c) Distinguish between soft and hard magnetic materials.
- [4+8+4]
- 3.(a) Explain in detail the principle of Optical fiber.
 - (b) Explain with necessary theory, the Fraunhofer diffraction due to 'n' slits.
 - (c) Find the relaxation time of conduction electrons in a metal of resistivity $1.54 \times 10^{-8} \Omega\text{-m}$, if the metal has 5.8×10^{28} conduction electrons per m^3 .
- [4+8+4]
- 4.(a) Derive the relation between the Einstein coefficients.
 - (b) Derive an expression for the electrical conductivity of a material in terms of mobility of the electron using classical free electron theory.
- [8+8]
- 5.(a) Explain the origin of magnetism in materials.
 - (b) Derive Sabine's formula for 'Reverberation time'.
- [4+12]
- 6.(a) Derive time dependent Schrodinger wave equation.
 - (b) Draw and explain B-H curve for a ferromagnetic material placed in a magnetic field.
- [8+8]
- 7.(a) State and explain Hall effect.
 - (b) Identify whether unit cells of SC, BCC and FCC lattices are primitive or not. Explain with reason.
 - (c) Write the difference between Spontaneous and Stimulated Emissions.

[6+6+4]



ENGINEERING PHYSICS

(Common to ECE, EEE, EIE, Bio-Tech, EComE, Agri.E)

Time: 3 hours

Max. Marks: 70

Question Paper Consists of **Part-A** and **Part-B**
Answering the question in **Part-A** is Compulsory,
Three Questions should be answered from **Part-B**

PART-A

- 1.(i) What are the necessary conditions for obtaining interference fringes?
 - (ii) What is meant by Intermodal dispersion in optical fibers? How to overcome this problem? Explain.
 - (iii) What are polar and non-polar dielectrics?
 - (iv) What are the fundamental laws of electromagnetism?
 - (v) Explain the salient features of Classical free electron theory?
 - (vi) Write notes on Direct and Indirect band gap semiconductors.
- [3+4+4+3+4+4]

PART-B

- 2.(a) What is meant by Diffraction of light? Explain it on the basis of Huygen's wave theory.
 - (b) Explain the working of Ruby laser with the help of neat energy level diagram.
 - (c) Draw the crystal planes having Miller indices (110) and (211).
- [5+8+3]
- 3.(a) Explain the origin of energy bands in solids.
 - (b) Derive expression for interplanar spacing between two adjacent planes of Miller indices (h, k, l) and lattice constant 'a'.
 - (c) Calculate the maximum number of orders possible for a plane diffraction grating
- [6+6+4]
- 4.(a) Discuss in detail the electronic, ionic and orientational polarizations and their dependence on temperature.
 - (b) Explain Meissner effect. Describe soft and hard superconductors.
- [8+8]
- 5.(a) Distinguish between conductors, semiconductors and insulators.
 - (b) Derive Sabine's formula for 'Reverberation time'.
- [4+12]
- 6.(a) Derive expression for Hall coefficient.
 - (b) Derive an expression for the effective mass of an electron moving in energy bands of a solid. Show how it varies with the wave vector.
 - (c) Define the terms 'Reverberation' and 'Reverberation time'.
- [6+6+4]
- 7.(a) Write notes on Direct and Indirect band gap semiconductors.
 - (b) Deduce an expression for Lorentz field relating to a dielectric material.
 - (c) The R_H of a specimen is $3.66 \times 10^{-4} \text{ m}^3 \text{ c}^{-1}$. Its resistivity is $8.93 \times 10^{-3} \Omega \text{m}$. Find mobility and charge carrier concentration.
- [4+8+4]



ENGINEERING PHYSICS

(Common to ECE, EEE, EIE, Bio-Tech, EComE, Agri.E)

Time: 3 hours

Max. Marks: 70

Question Paper Consists of **Part-A** and **Part-B**
Answering the question in **Part-A** is Compulsory,
Three Questions should be answered from **Part-B**

PART-A

- 1.(i) Distinguish between Interference and Diffraction.
- (ii) Explain the characteristic properties of laser.
- (iii) The penetration depths for Lead at 3K and 7.1K are 39.6nm and 173nm respectively. Calculate the critical temperature for Lead.
- (iv) Explain the terms 'Reverberation' and 'Reverberation time'.
- (v) Explain the concept of hole.
- (vi) Explain the electronic transport mechanism for Photo Conductors.

[3+4+4+3+4+4]

PART-B

- 2.(a) Derive expressions for Acceptance angle and Numerical Aperture of an Optical fiber.
 - (b) State Brewster's law. How can this law be used to produce plane polarized light?
 - (c) Explain in detail the flux quantization in a Superconducting ring.
- [8+4+4]
- 3.(a) Explain the principle of Optical fiber.
 - (b) Explain the principle, construction and working of a Nicol prism with neat diagram.
 - (c) What is meant by Intermodal dispersion in optical fibers? How to overcome this problem? Explain.
- [4+8+4]
- 4.(a) Discuss in detail the electronic, ionic and orientational polarizations and their dependence on temperature.
 - (b) Derive the expression for condition of maxima and minima for reflected light in case of thin transparent film of uniform thickness.
- [8+8]
- 5.(a) State and explain Stoke's theorem in its calculus form.
 - (b) Calculate the thickness of half wave plate of quartz for a wavelength 500nm. [Given that $\mu_e = 1.553$ and $\mu_o = 1.544$]
 - (c) Write a short notes on Rayleigh's Criterion.
- [6+4+6]
- 6.(a) Explain the salient features of Classical free electron theory.
 - (b) Explain with necessary theory, the Fraunhofer diffraction due to 'n' slits.
 - (c) Find the relaxation time of conduction electrons in a metal of resistivity $1.54 \times 10^{-8} \Omega\text{-m}$, if the metal has 5.8×10^{28} conduction electrons per m^3 .
- [4+8+4]
- 7.(a) What do you understand by drift and diffusion currents in the case of a semiconductor? Deduce Einstein's relation relating to these currents.
 - (b) Derive Eigen values and Eigen functions for a particle in a one dimensional potential box.
- [8+8]



ENGINEERING PHYSICS

(Common to ECE, EEE, EIE, Bio-Tech, EComE, Agri.E)

Time: 3 hours

Max. Marks: 70

Question Paper Consists of **Part-A** and **Part-B**
Answering the question in **Part-A** is Compulsory,
Three Questions should be answered from **Part-B**

PART-A

- 1.(i) Calculate the maximum number of orders possible for a plane diffraction grating.
- (ii) What is meant by Intermodal dispersion in optical fibers? How to overcome this problem? Explain.
- (iii) The penetration depths for Lead at 3K and 7.1K are 39.6nm and 173nm respectively. Calculate the critical temperature for Lead.
- (iv) What are the fundamental laws of electromagnetism?
- (v) Explain the concept of hole.
- (vi) Write notes on Direct and Indirect band gap semiconductors.

[3+4+4+3+4+4]

PART-B

- 2.(a) Derive expression for interplanar spacing between two adjacent planes of Miller indices (h, k, l) and lattice constant 'a'.
 - (b) State Brewster's law. How can this law be used to produce plane polarized light?
 - (c) Explain in detail the flux quantization in a Superconducting ring.
- [8+4+4]
- 3.(a) Identify whether unit cells of SC, BCC and FCC lattices are primitive or not. Explain with reason.
 - (b) Derive an expression for wavelength of light in Newton's rings experiment.
 - (c) Distinguish between soft and hard magnetic materials.
- [4+8+4]
- 4.(a) Explain the origin of magnetism in materials.
 - (b) Explain the principle, construction and working of a Nicol prism with neat diagram.
 - (c) Draw the crystal planes having Miller indices (110) and (211).
- [4+8+4]
- 5.(a) State and explain Stoke's theorem in its calculus form.
 - (b) The R_H of a specimen is $3.66 \times 10^{-4} \text{ m}^3 \text{ c}^{-1}$. Its resistivity is $8.93 \times 10^{-3} \Omega \text{m}$. Find mobility and charge carrier concentration.
 - (c) Derive an expression for the effective mass of an electron moving in energy bands of a solid. Show how it varies with the wave vector.
- [6+4+6]
- 6.(a) Explain the origin of energy bands in solids.
 - (b) Write notes on Rayleigh's Criterion.
 - (c) Derive expression for Hall coefficient.
- [6+6+4]
- 7.(a) State and explain Hall effect.
 - (b) Draw and explain B-H curve for a ferromagnetic material placed in a magnetic field.
 - (c) Calculate the thickness of half wave plate of quartz for a wavelength 500nm. [Given that $\mu_e = 1.553$ and $\mu_o = 1.544$]

[6+6+4]



ENGINEERING MECHANICS

(Common to CE, ME, CSE, PCE, IT, Chem E, Aero E, AME, Min E, PE, Metal E)

Time: 3 hours

Max. Marks: 70

Question Paper Consists of **Part-A** and **Part-B**
 Answering the question in **Part-A** is Compulsory,
 Three Questions should be answered from **Part-B**

PART-A

- 1.(i) State the laws of friction
- (ii) State and prove Lami's theorem
- (iii) A semi-circular area is removed from a trapezium as shown in Fig.1 (dimensions in mm).

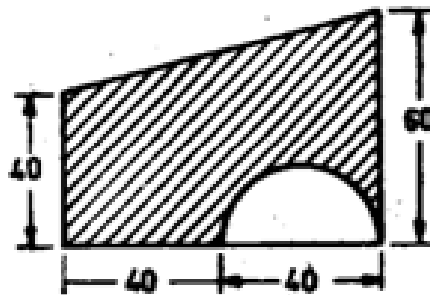

Fig:1

Determine the centroid of the remaining area (shown hatched).

- (iv) State and Prove the parallel axis theorem, to determine the moment of inertia of areas with the help of a neat sketch.
- (v) Establish the Relationship between Angular motion & linear motion
- (vi) Explain the concept of work? What are the units of work?

[3+4+5+6+2+2]

PART -B

- 2.(a) Three bars, hinged at A and D and pinned at B and C as shown in Fig:2 form a four-linked mechanism. Determine the value of P that will prevent movement of bars.

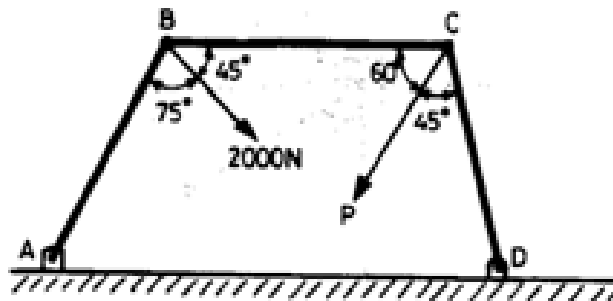

Fig:2

- (b) The position of a particle moving along a straight line is defined by the relation $x = t^3 - 9t^2 + 15t + 18$ where x is expressed in metre m and t in seconds. Determine the time, position, and acceleration of the particle when its velocity becomes zero?

[8+8]



- 3.(a) Determine the centroid of a triangle of base 'b' and height 'h'?
- (b) Three cylinders weighing 100 N each and of 80 mm diameter are placed in a channel of 180 mm width as shown in Fig:3

Determine the pressure exerted by (i) the cylinder A on B at the point of contact; (ii) the cylinder B on the base and on the wall.

[8+8]

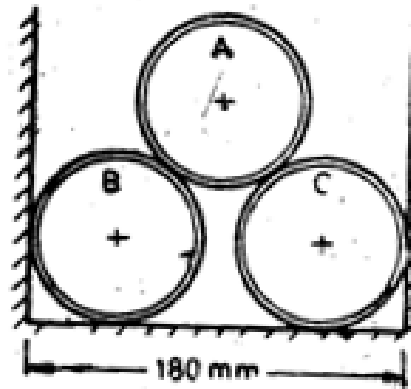

Fig.3

- 4.(a) Find the mass Moment of Inertia of circular plate of radius R and thickness t about its centroidal axis
- (b) A force of 250 N pulls a body of weight 500 N up an inclined plane, the force being applied parallel to the plane. If the inclination of the plane to the horizontal is 15° , find the coefficient of friction?

[8+8]

- 5.(a) Differentiate kinematics and kinetics?
- (b) Locate the co-ordinates of the centroid of the shaded area of a lamina shown in Fig:4?

[4+12]

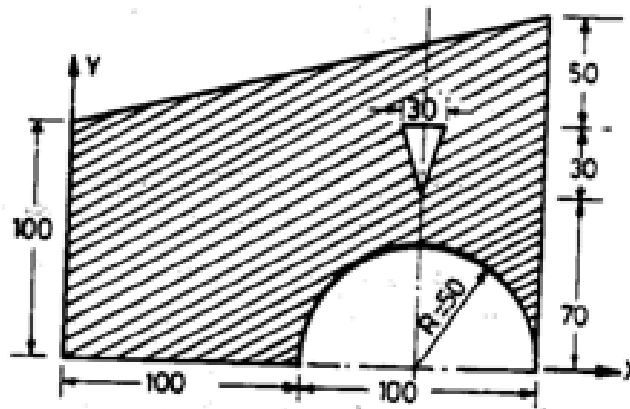

Fig:4



- 6.(a) Derive work energy equation for translation?
 (b) Two men carry a weight of 2 KN by means of two ropes fixed to the weight. One rope is inclined at 45° and the other at 30° with their vertices. Find the tension in each rope? [8+8]
- 7.(a) Locate the centre of gravity of the right circular cone of base radius r and height h shown in Fig:5

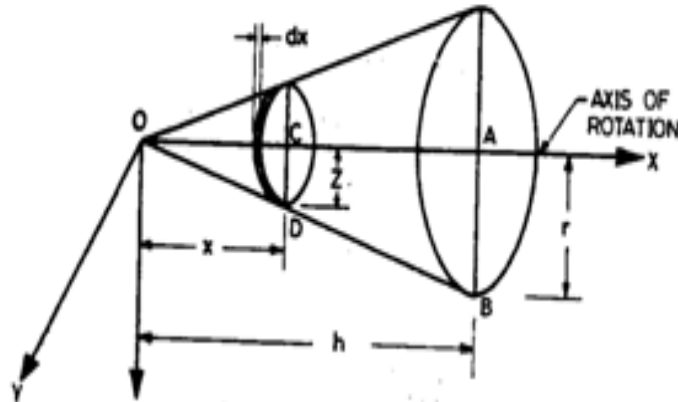

Fig:5

- (b) A bullet of weight 0.3 N is fired horizontally into a body of weight 100 N which is suspended by a string 0.8 m long. Due to this impact the body swings through an angle of 30° . Find the velocity of the bullet and the loss in the energy of the system? (as shown in Fig:6)

[8+8]

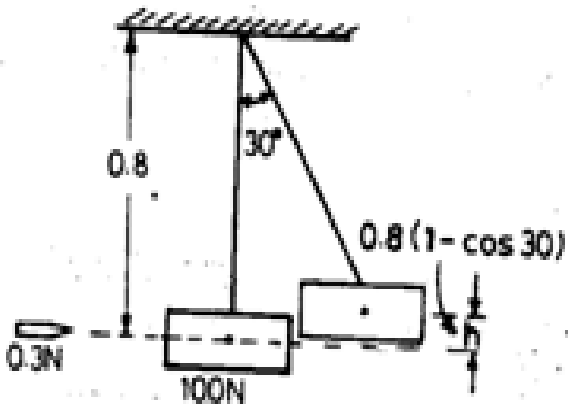

Fig:6



ENGINEERING MECHANICS

(Common to CE, ME, CSE, PCE, IT, Chem E, Aero E, AME, Min E, PE, Metal E)

Time: 3 hours**Max. Marks: 70**

Question Paper Consists of **Part-A** and **Part-B**
 Answering the question in **Part-A** is Compulsory,
 Three Questions should be answered from **Part-B**

PART-A

- 1.(i) Prove that angle of repose is same as the value of limiting angle friction?
- (ii) A uniform sphere of weight W rests between a smooth vertical plane and a smooth plane inclined at an angle with the vertical plane. Find the reaction at the contact surfaces.
- (iii) Determine the mass moment of inertia of a rectangular plate of size $a \times b$ and thickness about its centroidal axes.
- (iv) What is the difference between centroid and centre of gravity?
- (v) A stone is dropped into a well while splash is heard after 4.5 s. Another stone is dropped with an initial velocity v and the splash is heard after 4 s. If the velocity of a sound is 336 m/s, determine the initial velocity of second stone?
- (vi) Derive the equation for motion of connected bodies?

[3+4+4+4+4+3]

PART-B

- 2.(a) The block A shown in Fig.1 weighs 2000 N. The cord attached to A passes over a frictionless pulley and supports a weight equal to 800N. The value of coefficient of friction between A and the horizontal plane is 0.35. Solve for horizontal force P : (1) If motion is impending towards the left, and (2) If the motion is impending towards the right?

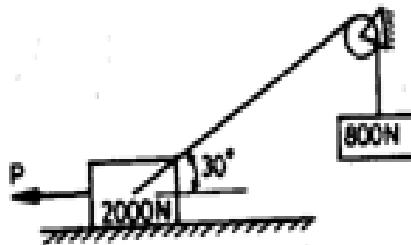

Fig.1

- (b) Derive work energy equation for translation?

[8+8]



- 3.(a) What is free body diagram and what are the rules for drawing FBD?
 (b) Determine the maximum height h of the cylindrical portion of the body with hemispherical base shown in Fig.2 so that it is in stable equilibrium on its base.

[4+12]

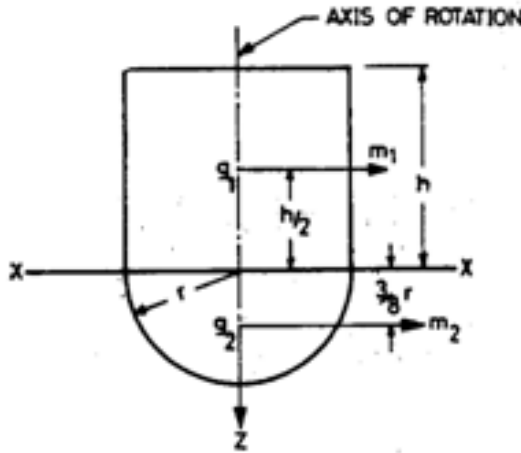

Fig.2

- 4.(a) Derive the centroid of a parabolic spandrel?
 (b) State the equations of equilibrium of a rigid body experiencing a planar motion? [8+8]
- 5.(a) Derive the Moment of Inertia of a quarter circle of radius 'r' about the base and the centroidal axes?
 (b) A tripod is acted upon by forces at 'P' as shown in the Fig.3 Determine the forces in the legs of tripod if the legs rest on ground at A, B and C whose coordinates with respect to O are as shown in the Fig.3 The height of 'P' above the origin is 10 m.

[8+8]

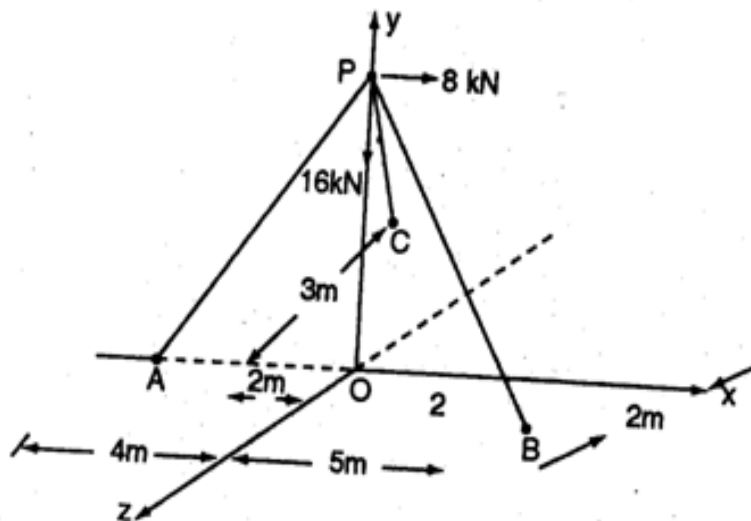
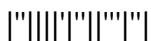

Fig.3



- 6.(a) A flywheel of 550 mm diameter is brought uniformly from rest up to a speed of 350 rpm in 20 s. Find the velocity and the acceleration of a point on its rim 3 s after starting from rest?
 - (b) The resultant of two forces acting at a point is 65 kN. It is observed that one force is double than that of the other and if the direction of one of them is reversed the resultant becomes 45 kN. Find the magnitudes of forces and the angle between them.
- [8+8]
- 7.(a) Determine the tension in the string and the velocity of 1500 N block shown in Fig.4 5 seconds after starting from
- (i) Rest
 - (ii) Starting with a downward velocity of 3 m/sec.
- Assume pulleys as weightless and frictionless.

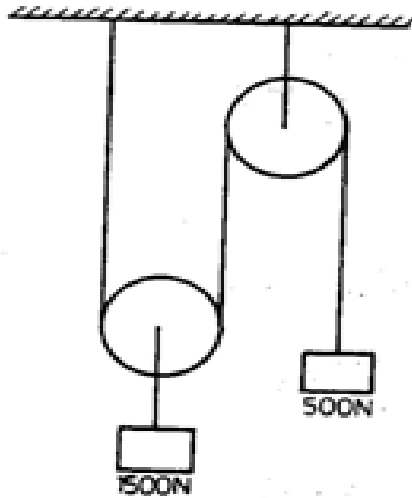
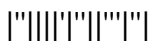

Fig.4

- (b) State and prove the Pappus theorems?

[10+6]



ENGINEERING MECHANICS

(Common to CE, ME, CSE, PCE, IT, Chem E, Aero E, AME, Min E, PE, Metal E)

Time: 3 hours**Max. Marks: 70**

Question Paper Consists of **Part-A** and **Part-B**
 Answering the question in **Part-A** is Compulsory,
 Three Questions should be answered from **Part-B**

PART-A

- 1.(i) State and prove Varignon's theorem?
 (ii) Three forces of magnitudes P, 100 N and 200 N are acting at a point O as shown in Fig.1 Determine the magnitude and direction of the force P

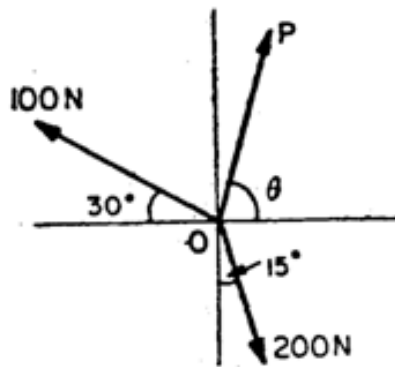

Fig.1

- (iii) Determine the CG of a flat plate of thickness 't', unit weight of the material ' γ '.
 (iv) Determine the mass moment of inertia of a uniform rod of length L about its: (a) centroidal axis normal to rod, and (b) axis at the end of the rod and normal to it.
 (v) A pendulum consists of a bob of 4 kg mass, supported by a thin rod pivoted at 1 m from the centre of the bob. The bob is moved, so that the rod makes an angle of 20° with the vertical and then released. What is the linear and angular velocity of the bob, when it swings back to the vertical position? The weight of the rod and the frictional resistance may be neglected?
 (vi) A bus is travelling on a curved portion of a highway of radius 600m at a speed of 108 km/h. The brakes are suddenly applied, which causes the speed to reduce at a constant rate of 1.5 m/s^2 . Calculate the magnitude of the total acceleration of the bus (i) immediately after the brakes have been applied. [4+4+3+4+4+3]

PART -B

- 2.(a) Two blocks A and B each weighing 1500 N are connected by a uniform horizontal bar which weighs 1000 N. If the angle of limiting friction under each block is 15° , find the force P directed parallel to the 60° inclined plane that will cause motion impending to the right. (as shown in Fig.2)



Fig.2



- (b) Determine the radius of gyration of the body shown in Fig.3 about centroidal x axis. The grooves are semicircular with radius 40 mm. All dimensions shown are in mm.

[8+8]

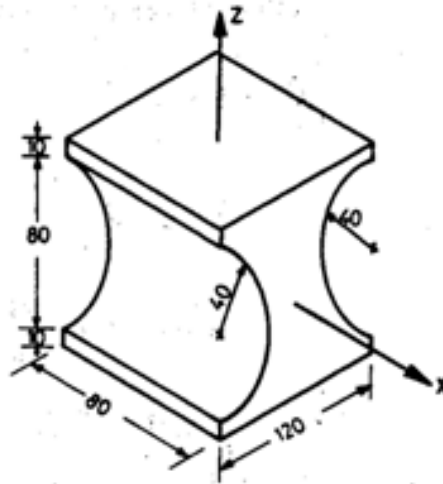

Fig.3

- 3.(a) Two cylinders, A of weight 4000 N and B of weight 2000 N rest on smooth inclines as shown in Fig.4. They are connected by a bar of negligible weight hinged to each cylinder at its geometric centre by smooth pins. Find the force P to be applied as show in the figure such that it will hold the system in the given position

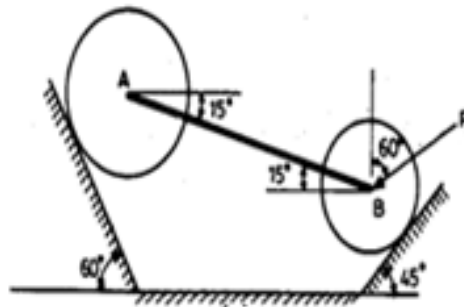
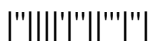

Fig.4

- (b) A wheel, rotating about a fixed axis at 30 r.p.m is uniformly accelerated for 50 seconds, during which time it makes 40 revolution. Find: (i) angular velocity at the end of this interval, and (ii) time required for the speed to reach 80 revolution per minute.

[8+8]



- 4.(a) Determine the coordinates x_c and y_c of the centre of a 100 mm diameter circular hole cut in a thin plate so that this point will be the centroid of the remaining shaded area shown in Fig.5 (All dimensions are in mm).

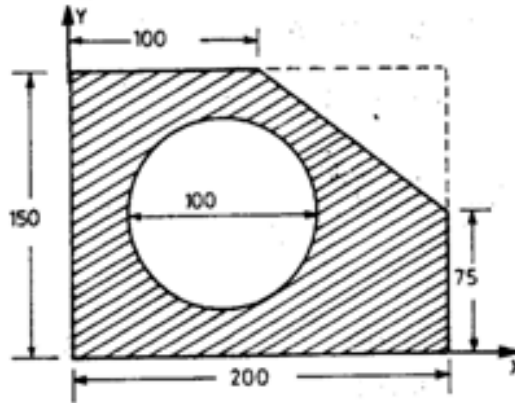

Fig.5

- (b) A gun of mass 2500 kg fires horizontally a shell of mass 40 kg with a velocity of 350 m/s. What is the velocity with which the gun will recoil? Also determine the force required to stop the gun in 0.8m. In how much time will it stop? [8+8]
- 5.(a) Determine the mass moment of inertia of a solid sphere of radius R about its diametral axis?
- (b) Two smooth spheres each of radius 100 mm and weight 100 N, rest in a horizontal channel having vertical walls, the distance between which is 360 mm. Find the reactions at the points of contacts A,B,C and D shown in Fig.6 (All dimensions are in mm)

[6+10]

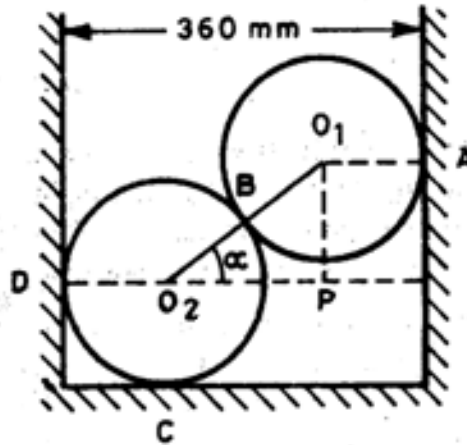
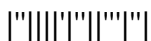

Fig.6



- 6.(a) An elevator of gross weight 4500 N starts to move upwards with a constant acceleration and acquires a velocity of 1.2 m/s after travelling a distance of 2.4 m. Find the pull in the cable during acceleration motion. If the elevator, when stopping, moves with a constant deceleration from a constant velocity of 1.8 m/s and comes to rest in 2 s, calculate the force transmitted by a man weighing 600 N to the floor during stopping.
- (b) What should be the value of μ in Fig.7 which will make the motion of 900 N block down the plane to impend? The coefficient of friction for all contact surfaces is $\frac{1}{3}$.

[8+8]

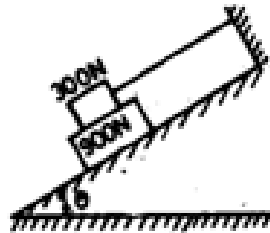

Fig.7

- 7.(a) Determine the constant force P that will give the system of bodies shown in Fig.8 a velocity of 3m/sec after moving 4.5 m from rest. Coefficient of friction between the blocks and the plane is 0.3. Pulleys are smooth.

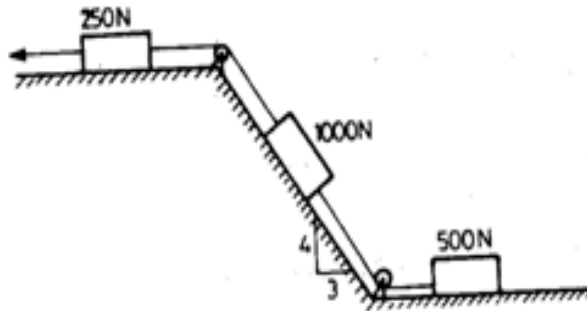

Fig.8

- (b) Locate the centroid of the I-section shown in Fig.9 (All dimensions are in mm)

[8+8]

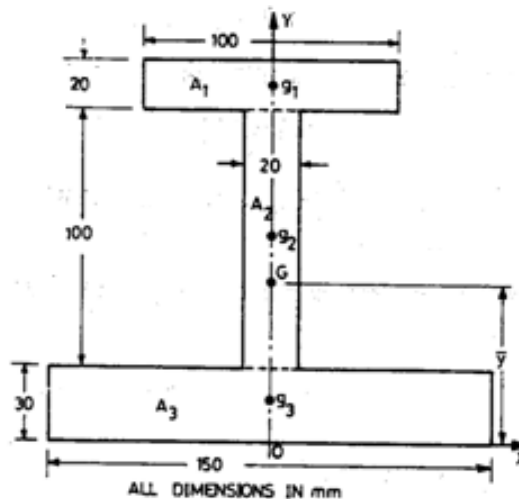

Fig.9



ENGINEERING MECHANICS

(Common to CE, ME, CSE, PCE, IT, Chem E, Aero E, AME, Min E, PE, Metal E)

Time: 3 hours

Max. Marks: 70

Question Paper Consists of **Part-A** and **Part-B**
 Answering the question in **Part-A** is Compulsory,
 Three Questions should be answered from **Part-B**

PART-A

- 1.(i) A force $F=10i+13j-12k$ acts a point O, which is the origin. Find the magnitude and the direction of the force.
- (ii) Write about different types of equilibrium?
- (iii) State and prove Pappus theorems?
- (iv) A semi-circle of 90 mm radius is cut out from a trapezium section as shown in Fig.1 (All dimensions are in mm)

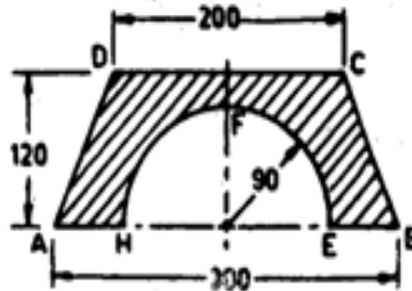

Fig.1

- (v) A bullet is fired at a angle of 45° with the horizontal with a velocity of 275 m/sec. How high the bullet will rise and what will be its horizontal range? Take $g=9.8 \text{ m/sec}^2$.
- (vi) A body weighing 300 N is pushed up a 30° plane by a 400 N force acting parallel to the plane. If the initial velocity of the body is 1.5 m/sec and coefficient of kinetic friction is $\mu=0.2$, what velocity will the body have after moving 6m?

[3+3+4+4+4+4]

PART-B

- 2.(a) Two smooth spheres each of radius 100 mm and weight 100 N, rest in a horizontal channel having vertical walls, the distance between which is 360 mm. Find the reactions at the points of contacts A,B,C and D shown in Fig.2 (All dimensions are in mm)

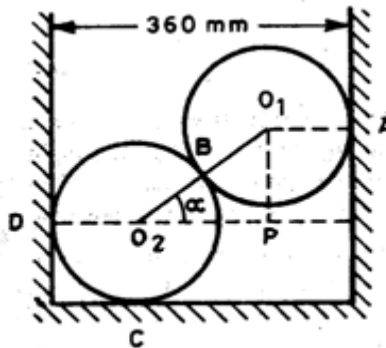

Fig.2



- (b) Determine the time required for the weights shown in Fig.3 to attain a velocity of 9.81 m/sec. What is tension in the chord? Take $\mu=0.2$ for both planes. Assume the pulleys as frictionless

[8+8]

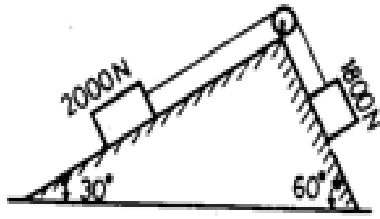

Fig.3

- 3.(a) A ladder 5 metres long rests on a horizontal ground and leans against a smooth vertical wall at an angle 70° with the horizontal. The weight of the ladder is 900 newtons and acts at its middle. The ladder is at the point of sliding, when a man weighing 750 newtons stands on a rung 1.5 metre from the bottom of the ladder.
- (b) Determine the constant force P that will give the system of bodies shown in Fig.4 a velocity of 3m/sec after moving 4.5 m from rest. Coefficient of friction between the blocks and the plane is 0.3. Pulleys are smooth.

[8+8]

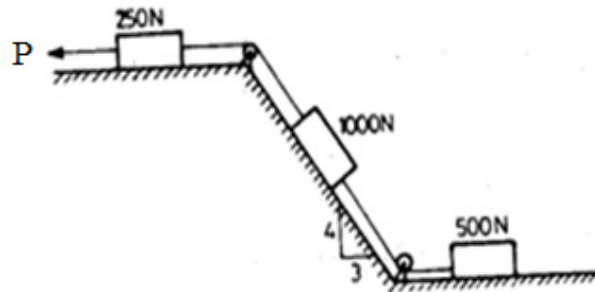

Fig.4

- 4.(a) Two blocks A and B each weighing 1500 N are connected by a uniform horizontal bar which weighs 1000 N. If the angle of limiting friction under each block is 15° , find the force P directed parallel to the 60° inclined plane that will cause motion impending to the right.(as shown in Fig.5)



Fig.5



- (b) Identify the co-ordinates of the centroid of plane area shown in Fig.6? (All dimensions are in mm)

[8+8]

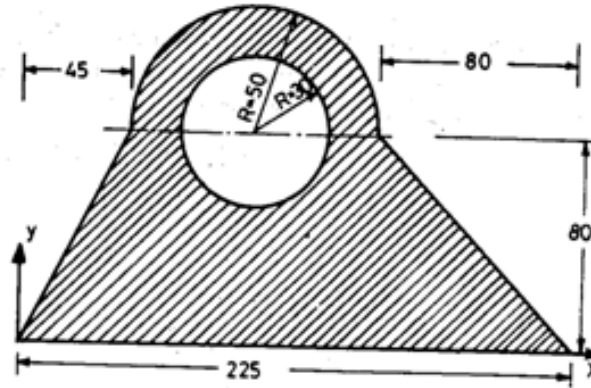

Fig.6

- 5.(a) Determine the coordinates x_c and y_c of the centre of a 100 mm diameter circular hole cut in a thin plate so that this point will be the centroid of the remaining shaded area shown in Fig.7 (All dimensions are in mm).

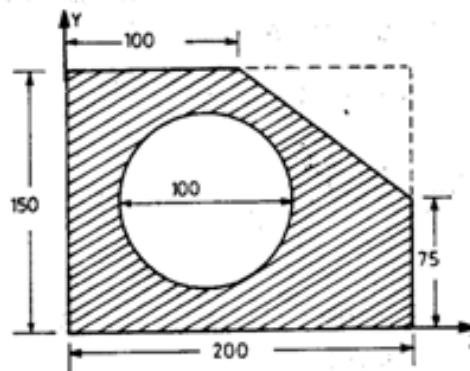

Fig.7

- (b) What is the value of P in the system shown in Fig.8 to cause the motion to impend? Assume the pulley is smooth and coefficient of friction between the other contact surfaces is 0.02.

[8+8]

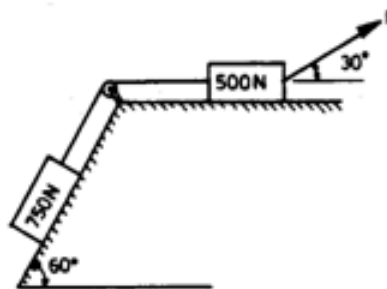

Fig.8



- 6.(a) Define (i) Angular displacement (ii) Angular velocity (iii) Angular acceleration.
 (b) Determine the coordinates of the centroid of the plane area shown in Fig.9 with reference to the axes shown. Take $x=40$ mm.

[8+8]

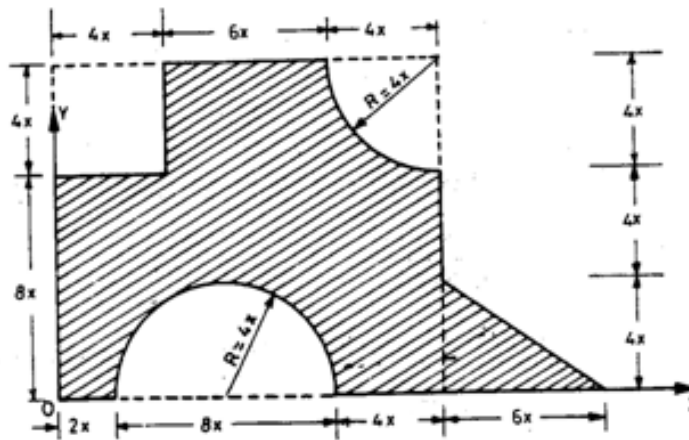
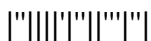

Fig.9

- 7.(a) Derive the parallel axis theorem in mass moment of inertia?
 (b) A stone is dropped into a well without initial velocity. Its splash is heard after 3.5 seconds. Another stone is dropped with some initial velocity and its splash is heard after 3 seconds. Determine the initial velocity of the second stone if velocity of sound is 335 m/sec.

[8+8]



**I B.Tech I Semester Supplementary Examinations, Feb/Mar 2014
ENGINEERING CHEMISTRY-I**

**(Common to Civil Engineering, Electrical & Electronics Engineering,
Mechanical Engineering, Electronics & Communication Engineering,
Computer Science & Engineering, Chemical Engineering, Electronics &
Instrumentation Engineering, Bio-Medical Engineering, Information
Technology, Electronics & Computer Engineering, Aeronautical
Engineering, Automobile Engineering, Mining and Petroleum Technology)**

Time: 3 hours

Max Marks: 75

**Answer any FIVE Questions
All Questions carry equal marks**

1. (a) Apply the concept of solubility product for different types of salts and derive expressions for the same.
(b) Calculate the solubility of BaSO_4 provided, its solubility product is 1.6×10^{-10} .
[8+7]
2. (a) The time of flow for certain volume of water through a viscometer is 120.5 sec. whereas the time of flow for the same volume of acetone is 49.5 sec. The densities of water and acetone at 293K are $9.982 \times 10^2 \text{Kg.m}^{-3}$ and 7.92Kg.m^{-3} respectively. If the viscosity of water at 293K is 10.05 Pascal, calculate the viscosity of acetone.
(b) Explain the uses of dialysis and ultra filtration in the purification of colloidal solutions.
[8+7]
3. Write short notes on the following
 - (a) Biosensors
 - (b) Ion-selective electrodes
 - (c) Basic Principle involved in $^1\text{H-NMR}$ Spectroscopy [5+5+5]
4. (a) Explain the principle of photocopying process by using selenium photoconductor
(b) What are the important features of
 - (i) Stoichiometric semiconducting materials and
 - (ii) Controlled valency semiconducting materials? [7+8]
5. (a) Explain the determination & importance of Percentage of carbon and Hydrogen in ultimate Analysis
(b) Discuss the working of bomb calorimeter ? [7+8]
6. (a) Write the different types of fuel cells?
(b) Write down the characteristics of fuel cells? [8+7]
7. (a) What are Mass defect and Binding energy?

Code No: R10104/R10

Set No. 1

- (b) Explain nuclear stability using Binding energy concept? [8+7]
8. (a) What gases cause enhanced green house effect?
- (b) What are its disadvantages? How can it be prevented? [7+8]



**I B.Tech I Semester Supplementary Examinations, Feb/Mar 2014
ENGINEERING CHEMISTRY-I**

**(Common to Civil Engineering, Electrical & Electronics Engineering,
Mechanical Engineering, Electronics & Communication Engineering,
Computer Science & Engineering, Chemical Engineering, Electronics &
Instrumentation Engineering, Bio-Medical Engineering, Information
Technology, Electronics & Computer Engineering, Aeronautical
Engineering, Automobile Engineering, Mining and Petroleum Technology)**

Time: 3 hours

Max Marks: 75

**Answer any FIVE Questions
All Questions carry equal marks**

1. (a) Explain the terms solubility product and common ion effect.
(b) What are the applications of solubility product ? [8+7]
2. (a) Discuss on industrial applications of colloids.
(b) Discuss in detail the manufacture of ethyl alcohol from starch? [8+7]
3. (a) How can you estimate fluoride, chloride and nitrate ions quantitatively using ion-selective electrodes
(b) Explain Coupling constant in brief. [12+3]
4. (a) Write note on various types of semiconductors
(b) What is doping? Discuss different doping techniques to prepare semiconductors
(c) Explain phenomenon of superconductivity [5+7+3]
5. (a) Explain carbonization of coal?
(b) Differentiate low - temperature and High temperature carbonization. [7+8]
6. (a) What is concentration cell? Explain with suitable example Derive the expression for emf of concentration cell?
(b) Write notes on calomel electrode [10+5]
7. (a) Where are the atomic power stations in India? Mention them.
(b) Describe the principle and working process of a nuclear power plant. [3+12]
8. (a) Define solar constant. Give its value on the upper atmosphere and on the lower atmosphere.
(b) How are solar energy devices are classified? Explain.
(c) What is the use of plane mirror of a box type of solar cooker? [5+5+5]

**I B.Tech I Semester Supplementary Examinations, Feb/Mar 2014
ENGINEERING CHEMISTRY-I**

(Common to Civil Engineering, Electrical & Electronics Engineering,
Mechanical Engineering, Electronics & Communication Engineering,
Computer Science & Engineering, Chemical Engineering, Electronics &
Instrumentation Engineering, Bio-Medical Engineering, Information
Technology, Electronics & Computer Engineering, Aeronautical
Engineering, Automobile Engineering, Mining and Petroleum Technology)

Time: 3 hours

Max Marks: 75

**Answer any FIVE Questions
All Questions carry equal marks**

1. (a) What is a semi-permeable membrane? Mention different types with examples.
(b) What are the advantages, disadvantages and limitations of reverse osmosis?
[8+7]
2. (a) What are the different classes of colloidal systems? Explain with examples
(b) Write about the important characteristics of enzymes. [8+7]
3. (a) Discuss ion-selective electrodes in detail and outline the interferences during their working.
(b) What is the significance of Joblonski diagram in photochemistry? [9+6]
4. (a) What are smectic liquid crystals? How are they classified? Mention their salient features
(b) Outline the various applications of superconductors [10+5]
5. (a) Define Calorific value, Higher (or) Gross calorific value, lower (or) Net calorific value?
(b) Calculate the gross & net Calorific value of a sample of coal having following composition. C = 80% , H = 7% , O = 3% , S = 3.5% , N = 2.1% , and Ash = 4.4%
[8+7]
6. (a) Write a notes on fuel cell
(b) Discuss the working principle of primary batteries? [7+8]
7. Write short notes on the following:
(a) Nuclear fission
(b) Nuclear Fusion
(c) Nuclear reactor [5+5+5]
8. (a) What is green house effect? Explain.
(b) How it is useful to mankind? [8+7]

**I B.Tech I Semester Supplementary Examinations, Feb/Mar 2014
ENGINEERING CHEMISTRY-I**

**(Common to Civil Engineering, Electrical & Electronics Engineering,
Mechanical Engineering, Electronics & Communication Engineering,
Computer Science & Engineering, Chemical Engineering, Electronics &
Instrumentation Engineering, Bio-Medical Engineering, Information
Technology, Electronics & Computer Engineering, Aeronautical
Engineering, Automobile Engineering, Mining and Petroleum Technology)**

Time: 3 hours

Max Marks: 75

**Answer any FIVE Questions
All Questions carry equal marks**

1. (a) Write on the differences between osmosis and reverse osmosis
(b) List out the conditions favorable for the higher yield of ammonia by applying Lechatelier's principle [8+7]
2. (a) Explain the determination of molecular weight of compound by viscosity method?
(b) Discuss in detail the manufacture of acetic acid. [8+7]
3. (a) How can you interpreting $^1\text{H-NMR}$ spectra
(b) Explain the theory of preparation, manufacturing of electrode and interferences in the determination of Fluoride ion [10+5]
4. (a) Write a detailed note on Chalcogen photoconductors and Defect semiconductors
(b) Distinguish between p-type and n-type semiconductors [10+5]
5. (a) Explain carbonization of coal?
(b) Differentiate low - temperature and High temperature carbonization. [7+8]
6. (a) Explain the working of Calomel electrode?
(b) Explain the working of Ag / AgCl electrode? [8+7]
7. (a) Explain the differences between chemical reactions and nuclear reactions.
(b) What are radioactive isotopes? Discuss the applications of radio active isotopes. [8+7]
8. (a) What are the advantages and disadvantages of solar energy?
(b) Discuss the principle and working of solar thermal power plant. [7+8]
