

ENGINEERING CHEMISTRY

(Common to CE,ME,CSE,PCE,IT,Chem E,Aero E,AME,Min E,PE,Metal E)

Time: 3 hours**Max. Marks: 70**

Question Paper Consists of **Part-A** and **Part-B**
 Answering the question in **Part-A** is Compulsory,
 Three Questions should be answered from **Part-B**

PART-A

- 1.(a) Discuss (i) p-type doped conducting polymers (ii) phosphate conditioning (iii) antiknocking agents
- (b) Write a note on protection (against corrosion) of a metal by metallic coatings.
- (c) A 0.1 M KCl solution, whose specific conductance is $0.01571 \text{ mho cm}^{-1}$, has a conductance of 0.014 mho. When the same conductivity cell is used a 0.1 M chloroacetic acid solution has a conductance of $7.84 \times 10^{-3} \text{ mho}$. If the ionic conductance of $\text{ClCH}_2\text{COO}^-$ and H^+ are 59.8 and $449.8 \text{ mho cm}^2 \text{equiv.}^{-1}$, find the degree of dissociation of chloroacetic acid.

[12+4+6]

PART-B

- 2.(a) Describe cold and hot lime soda processes with a neat diagram.
 - (b) A sample of water on analysis has been found to contain the following in ppm: $\text{Ca}(\text{HCO}_3)_2 = 4.86$; $\text{Mg}(\text{HCO}_3)_2 = 5.84$, $\text{CaSO}_4 = 6.8$, $\text{MgSO}_4 = 8.4$. Calculate the temporary and permanent hardness of water.
 - (c) Discuss (i) stereospecific polymers (ii) mechanical properties of polymers
- [6+4+6]
- 3.(a) What is ion-selective electrode? Explain its working.
 - (b) Discuss potentiometric titrations.
 - (c) Write notes on (i) Refining of petrol (ii) reforming
- [6+4+6]
- 4.(a) Explain the factors effecting the rate of corrosion.
 - (b) Write notes on Electroplating
 - (c) Discuss (i) bullet proof plastics (ii) green house effects
- [6+4+6]
- 5.(a) Explain compounding and vulcanization of rubber.
 - (b) What is copolymerization. Give any two examples.
 - (c) Write notes on (i) caustic embrittlement (ii) galvanizing
- [7+3+6]
- 6.(a) Write notes on (i) LPG (ii) diesel knocking (iii) Ni-Cd battery
 - (b) A sample of coal was found to contain the following constituents: C = 81%; O=7%; S=2%; N=5.5% and ash=4.5%. Calculate the minimum amount of air required for complete combustion of 1 kg of coal.
 - (c) Explain break-point chlorination of water.
- [9+4+3]
- 7.(a) Write any four applications of carbon nanotubes.
 - (b) Explain the working of photovoltaic cells with a neat sketch.
 - (c) Write notes on (ii) Impressed current cathodic protection (ii) galvanic cell
- [5+5+6]



Subject Code: R13104/R13

Set No - 2

I B. Tech I Semester Regular Examinations Feb./Mar. - 2014

ENGINEERING CHEMISTRY

(Common to CE,ME,CSE,PCE,IT,Chem E,Aero E,AME,Min E,PE,Metal E)

Time: 3 hours

Max. Marks: 70

Question Paper Consists of **Part-A** and **Part-B**
Answering the question in **Part-A** is Compulsory,
Three Questions should be answered from **Part-B**

PART-A

- 1.(a) Name the various fractions obtained during fractional distillation of crude oil and indicate their boiling point ranges and uses of various fractions.
- (b) The ion conductance of H^+ and butyrate ions are 339.8 and $30.6 \text{ Scm}^2 \text{ equiv}^{-1}$ respectively. When same conductance cell is employed 0.1 M KCl and 0.1 M butyric acid recorded conductances of 1.3×10^{-2} and $5.25 \times 10^{-4} \text{ Scm}^2$ respectively. If the conductivity of the above KCl solution is 0.0121 S cm^{-1} , calculate the degree of dissociation of butyric acid.
- (c) Write notes on (i) turbine deposits (ii) Anodized coatings (iii) Solar reflectors

[6+7+9]

PART-B

- 2.(a) Describe (i) zeolite process (ii) Priming and foaming
 - (b) Calculate the amount of lime and soda required for the softening of 150 liters of water, which is analyzed as: temporary hardness = 20 ppm; permanent hardness = 15 ppm; permanent Mg hardness = 10 ppm.
 - (c) Discuss the preparation of Bakelite and Thiokol and mention their uses.
- [6+4+6]
- 3.(a) Explain with neat diagrams the working of (i) glass electrode (ii) concentration cell (iii) Lechlanche cell
 - (b) Describe any one method of catalytic cracking process for obtaining gasoline.
- [10+6]
- 4.(a) Explain electrochemical corrosion.
 - (b) Explain galvanizing and tinning.
 - (c) Describe any two methods of synthesis in green chemistry.
- [6+4+6]
- 5.(a) Describe with neat sketches, any two moulding techniques of plastics.
 - (b) What are the drawbacks of natural rubber.
 - (c) What are the different constituents of paints and give their function.
 - (d) Write notes on caustic embrittlement.
- [6+4+3+3]
- 6.(a) Define calorific value, HCV and LCV. Calculate the gross and net calorific value of coal having the following compositions C = 83%; H = 10%; S = 1%, N = 3%, Ash = 3%.
Latent heat of steam = 587 cal/g.
 - (b) Discuss (i) applications of Kohlrausch law (ii) scales and sludges
- [10+6]
- 7.(a) Write notes on (i) deterioration of cement concrete (ii) Types of Liquid crystals (iii) Need of green chemistry
 - (b) Explain (i) electrochemical cell (ii) metal cladding

[10+6]



Subject Code: R13104/R13

Set No - 3

I B. Tech I Semester Regular Examinations Feb./Mar. - 2014

ENGINEERING CHEMISTRY

(Common to CE,ME,CSE,PCE,IT,Chem E,Aero E,AME,Min E,PE,Metal E)

Time: 3 hours

Max. Marks: 70

Question Paper Consists of **Part-A** and **Part-B**
Answering the question in **Part-A** is Compulsory,
Three Questions should be answered from **Part-B**

PART-A

- 1.(a) Write notes on (i) CNG (ii) properties of Thiokol (iii) phosphate coatings
- (b) Explain the mechanism of setting and hardening of cement.
- (c) Calculate the amount of lime (84% pure) and soda (92% pure) required for softening 10, 000 litres of water containing the following salts per litre:
Ca(HCO₃)₂ = 40.5 mg; Mg(HCO₃)₂ = 36.5 mg; MgSO₄ = 37 mg; CaSO₄ = 34 mg;
CaCl₂ = 27.75 mg and NaCl = 10 mg. Also calculate the temporary hardness and permanent hardness of the water sample.

[7+6+9]

PART-B

- 2.(a) Describe with neat sketch ion exchange process of softening of water.
 - (b) Write notes on (i) scales and sludges (ii) turbidity
 - (c) What is condensation polymerization? Explain with example.
- [6+8+2]
- 3.(a) Describe the construction and working of hydrogen-oxygen fuel cell.
 - (b) At 25 °C, the equivalent conductivities at infinite dilution of HCl, CH₃COONa and NaCl are 428.03, 93.3, and 125.78 ohm⁻¹cm² equiv⁻¹ respectively. Calculate the equivalent conductance of acetic acid at infinite dilution
 - (c) Discuss the ultimate analysis of coal
- [7+3+6]
- 4.(a) Discuss the mechanism of dry corrosion. Explain the role of oxide film in dry corrosion.
 - (b) Explain the importance of design and selection of materials in controlling corrosion.
 - (c) Describe any two preparation methods for carbon nanotubes with neat sketch diagrams.
- [6+4+6]
- 5.(a) Explain free radical mechanism of addition polymerization.
 - (b) Write the preparation and uses of (i) PVC (ii) Bakelite
 - (c) Write notes on (i) Reverse Osmosis (ii) anodic and cathodic inhibitors
- [4+6+6]
6. Write notes on (i) refining (ii) octane number (iii) antiknocking agents (iv) cold lime soda process (v) calomel electrode
- [16]
- 7.(a) Write any four applications of (i) green chemistry (ii) liquid crystals (iii) fullerenes
 - (b) Write notes on (i) drying, semidrying and nondrying oils (ii) Kohlrausch law

[10+6]



I B. Tech I Sem Regular Examinations Feb./Mar. - 2014

ENGINEERING CHEMISTRY

(Common to CE,ME,CSE,PCE,IT,Chem E,Aero E,AME,Min E,PE,Metal E)

Time: 3 hours**Max. Marks: 70**

Question Paper Consists of **Part-A** and **Part-B**
 Answering the question in **Part-A** is Compulsory,
 Three Questions should be answered from **Part-B**

PART-A

- 1.(a) Write notes on (i) breakpoint chlorination (ii) ionic liquids as green solvents for green synthesis (iii) electroless plating
- (b) A sample of coal containing 93% C; 5% H; 2% ash. When this coal was tested in the laboratory for its calorific value in the bomb calorimeter, the following data was obtained: Weight of coal burnt = 0.95 g; Weight of water taken = 600g water equivalent of bomb and calorimeter = 2,000 g, rise of temperature = 2.84°C ; Cooling correction = 0.02°C ; Fuse wire correction = 12.0 cal; acid correction = 55 cal. Calculate the net and gross calorific value of the coal in cal/g. (Assume the latent heat of condensation of steam as 580 cal/g)
- (c) Compare galvanic series with electrochemical series.

[12+5+5]

PART-B

- 2.(a) Write notes on (i) demineralization process (ii) sterilization of water
 - (b) A sample of water contains the following dissolved salts per litre: $\text{Mg}(\text{HCO}_3)_2 = 25$ mg; $\text{MgCl}_2 = 28$ mg; $\text{CaSO}_4 = 24$ mg; $\text{CaCl}_2 = 84$ mg. Calculate the temporary and permanent hardness.
 - (c) Discuss the physical and mechanical properties of polymers.
- [6+4+6]
- 3.(a) What are secondary batteries? Give an example and explain its construction and working.
 - (b) Describe conductometric titrations of acids and bases.
 - (c) Write notes on (i) petrol knocking and diesel knocking (ii) characteristics of a good fuel.
- [5+5+6]
- 4.(a) Discuss on differential aeration corrosion
 - (b) Write notes on (i) Pilling- Bed worth rule (ii) passivity (iii) solar cells (iv) chemical vapour deposition method of CNTs
- [4+12]
- 5.(a) Write notes on (i) stereospecific polymers (ii) Injection moulding (iii) vulcanization
 - (b) Explain (i) metal cladding (ii) calgon and phosphate conditioning
- [10+6]
- 6.(a) Describe moving bed catalytic cracking method with a neat labeled diagram.
 - (b) Write notes on flue analysis and its significance.
 - (c) Explain how specific and equivalent conductances of a strong electrolyte vary with dilution.
 - (d) Discuss boiler corrosion.

[6+4+3+3]



- 7.(a) Write notes on (i) applications of liquid crystals (ii) any one method of green synthesis (iii) fiber reinforced plastics
- (b) Discuss sacrificial anodic protection method.
- (c) Calculate the emf of the following cell: $\text{Zn (s)}/\text{Zn}^{2+} (0.1 \text{ M})//\text{Cu}^{2+} (1.50\text{M})/\text{Cu(s)}$ at 25°C . $E^\circ_{\text{Zn}^{2+}/\text{Zn (s)}} = -0.76 \text{ V}$ and $E^\circ_{\text{Cu}^{2+}/\text{Cu(s)}} = +0.34 \text{ V}$.

[10+3+3]

PDFill PDF Editor with Free Writer and Tools



I B. Tech I Semester Regular Examinations Feb./Mar. - 2014
MATHEMATICS-II (MATHEMATICAL METHODS)

(Common to ECE, EEE, EIE, Bio-Tech, EComE, Agri.E)

Time: 3 hours

Max. Marks: 70

Question Paper Consists of **Part-A** and **Part-B**
 Answering the question in **Part-A** is Compulsory,
 Three Questions should be answered from **Part-B**

PART-A

- 1.(i) Write the sufficient condition for the convergence of Newton-Raphson method?
- (ii) Show that $\mu\delta = \frac{1}{2}(\Delta + \nabla)$?
- (iii) Write the merits and demerits of Euler Modified method?
- (iv) Write the Dirichlet's conditions of $f(x)$?
- (v) State Initial and Final value theorems of Z-transforms?
- (vi) Write the statement of Fourier integral theorem?

[3+4+4+3+4+4]

PART-B

- 2.(a) Using Runge-Kutta method of fourth order solve $y' = xy$, $y(1) = 2$ at $x = 1.2$ with $h = 0.2$.
 - (b) Find the Fourier transform of $f(x) = x^{-1}$
3. For the following data estimate $f(1.9)$ using forward, $f(2.68)$ using backward and $f(2.36)$ using central difference formula.

[8+8]

x	1.6	1.8	2.0	2.2	2.4	2.6	2.8	3.0
f(x)	0.0495	0.0600	0.0739	0.0903	0.1102	0.1346	0.1644	0.2009

[16]

- 4.(a) Solve the differential equation $\frac{dy}{dx} = x + y$ subject to $y(0) = 1$ by Picard's method and hence find $y(0.2)$.
- (b) Using Regula Falsi method find a real root of $f(x) = 2x^7 + x^5 + 1 = 0$ correct upto two decimal places.

[8+8]

- 5.(a) Find the Fourier series for $f(x) = 2lx - x^2$ in $(0, 2l)$, hence show that

$$\frac{1}{1^2} - \frac{1}{2^2} + \frac{1}{3^2} - \frac{1}{4^2} + \dots = \frac{\pi^2}{12}$$

- (b) Find the inverse Z transform of $\frac{3z^2+z}{(5z-1)(5z-2)}$

[8+8]



- 6.(a) Find the Fourier transform of $f(x) = \begin{cases} 1 - x^2, & |x| < 1 \\ 0, & |x| > 1 \end{cases}$
(b) Find a real root of $f(x) = x + \log x - 2$ using Newton-Raphson method.

[8+8]

- 7.(a) Find Z-transform of (i) $an^2 + bn + c$ (ii) $\sin(3n + 5)$
(b) Find the half range Fourier sine series for $f(x) = x$ in $(0, \pi)$?

[8+8]

PDFill PDF Editor with Free Writer and Tools



I B. Tech I Semester Regular Examinations Feb./Mar. - 2014
MATHEMATICS-II (MATHEMATICAL METHODS)

(Common to ECE, EEE, EIE, Bio-Tech, EComE, Agri.E)

Time: 3 hours

Max. Marks: 70

Question Paper Consists of **Part-A** and **Part-B**
 Answering the question in **Part-A** is Compulsory,
 Three Questions should be answered from **Part-B**

PART-A

- 1.(i) State Intermediate Value theorem?
- (ii) Show that $\Delta(e^{ax} \log bx)$?
- (iii) Write the second order Runge-Kutta formula?
- (iv) Give any one application of Fourier Series with example?
- (v) State the convolution theorem of inverse Z-transforms?
- (vi) Write the formulas Fourier cosine and sine transform?

[4+3+4+3+4+4]

PART- B

- 2.(a) Using modified Euler's method to find the value of y at x = 0.2 with h = 0.1 where $y' = 1 - y, y(0) = 0$
 - (b) Find the Fourier transform of $f(x) = \begin{cases} 1, & |x| < a \\ 0, & |x| > a \end{cases}$
- 3.(a) Prove the relation $\sum_{k=0}^{n-1} \Delta^2 f_k \equiv \Delta^2 f_0 - \Delta^2 f_n$
- (b) Use Lagrange's interpolation formula to calculate f(3) from the following table.

[8+8]

x	0	1	2	4	5	6
f(x)	1	4	15	5	6	19

[4+12]

- 4.(a) Solve the differential equation $\frac{dy}{dx} = x^2 y$ subject to $y(0) = 1$ by Taylor series method and hence find $y(0.1), y(0.2)$.
 - (b) Using bisection method find a root of $f(x) = x - \cos x = 0$.
- 5.(a) Obtain the Fourier series for $f(x) = |x|$ in $[-\pi, \pi]$, hence show that $\frac{1}{1^2} + \frac{1}{3^2} + \frac{1}{5^2} + \dots = \frac{\pi^2}{8}$
- (b) Solve $u_{n+2} + 4u_{n+1} + 3u_n = 3^n$ with $u_0 = 0; u_1 = 1$ using Z transforms

[8+8]

[8+8]



- 6.(a) Using Fourier integral, prove that $e^{-ax} = \frac{2a}{\pi} \int_0^{\infty} \frac{\cos ax}{a^2 + \alpha^2} d\alpha$, $a > 0, x > 0$
(b) Find a real root of $f(x) = x \log_{10} x = 1.2$ using Newton-Raphson method. [8+8]

- 7.(a) Find the Z transform of (i) $\cos(n + 1)\theta$ (ii) $\sin h \frac{n\pi}{2}$
(b) Obtain the Fourier series for spectrum of a periodic function with example? [8+8]

PDFill PDF Editor with Free Writer and Tools



I B. Tech I Semester Regular Examinations Feb./Mar. - 2014
MATHEMATICS-II (MATHEMATICAL METHODS)

(Common to ECE, EEE, EIE, Bio-Tech, EComE, Agri.E)

Time: 3 hours

Max. Marks: 70

Question Paper Consists of **Part-A** and **Part-B**
 Answering the question in **Part-A** is Compulsory,
 Three Questions should be answered from **Part-B**

PART-A

- 1.(i) Write the sufficient condition for the convergence of Newton-Raphson method?
 - (ii) Show that $\mu\delta = \frac{1}{2}(\Delta + \nabla)$?
 - (iii) Write the advantages & disadvantages of Taylor series method?
 - (iv) Write the Fourier series when the given function f(x) is an even?
 - (v) Write the properties of multiplication by n and division by n of Z-transforms?
 - (vi) Write the complex form of Fourier integral theorem?
- [3+3+4+4+4+4]

PART-B

- 2.(a) Using iteration method find a real root of $f(x) = x^2 - 3x + 1$ correct upto three decimal places starting with $x=1$.
 - (b) Solve $u_{n+2} - 2u_{n+1} + u_n = 3n + 5$ using Z-Transforms?
- [8+8]
- 3.(a) Evaluate $\Delta(e^{ax} \log bx)$
 - (b) By using Lagrange's interpolation formula, fit a polynomial data

x	0	1	3	4
f(x)	-12	0	6	12

[4+12]

- 4.(a) Using modified Euler method solve numerically the equation $\frac{dy}{dx} = 2 + \sqrt{xy}$ with $y(1) = 1$ to find $y(1.2)$
 - (b) Find f(x) if its Fourier sine transform is $\frac{s}{1+s^2}$
- [8+8]
- 5.(a) Obtain the Fourier series for $f(x) = (\pi - x)^2$ in $0 < x < 2\pi$, hence deduce that $\frac{1}{1^2} + \frac{1}{2^2} + \frac{1}{3^2} + \dots = \frac{\pi^2}{6}$
 - (b) Using convolution theorem, evaluate $Z^{-1}\left[\frac{z^2}{z^2-4z+3}\right]$
- [8+8]



6.(a) Using Parseval's identities, prove that $\int_0^{\infty} \frac{dt}{(a^2 + t^2)(b^2 + t^2)} = \frac{\pi}{2ab(a + b)}$

(b) Using Runge-Kutta method of third order, find the values of $y(x)$ for $x = 0.1, 0.2$ where $y' = x - 2y, y(0) = 1$.

[8+8]

7.(a) Find the half range sine series for $f(x) = x(\pi - x)$ in $(0, \pi)$

(b) Find a real root of $f(x) = x^3 - 19$ correct upto three decimal places using Newton-Raphson method

[8+8]

PDFill PDF Editor with Free Writer and Tools



I B. Tech I Semester Regular Examinations Feb./Mar. - 2014
MATHEMATICS-II (MATHEMATICAL METHODS)

(Common to ECE, EEE, EIE, Bio-Tech, EComE, Agri.E)

Time: 3 hours

Max. Marks: 70

Question Paper Consists of **Part-A** and **Part-B**
 Answering the question in **Part-A** is Compulsory,
 Three Questions should be answered from **Part-B**

PART-A

- 1.(i) Show that $\mu\delta = \frac{1}{2}(\Delta + \nabla)$?
- (ii) Write the merits and demerits of Iteration method?
- (iii) Write the merits and demerits of Euler Modified method?
- (iv) Write the Dirichlet's conditions of f(x)?
- (v) State convolution theorem of Z-transforms?
- (vi) Write the statement of Fourier integral theorem?

[3+4+4+3+4+4]

PART-B

- 2.(a) Find the Fourier sine and cosine transforms of $(2.e^{-5x} + 5.e^{-2x})$.

(b) Given $f(x) = \begin{cases} 1-x, & -\pi \leq x \leq 0 \\ 1+x, & 0 \leq x \leq \pi \end{cases}$

Is the function even or odd? Find the Fourier series for f(x).

[8+8]

- 3.(a) Prove the relation between E and D?
- (b) For the following data estimate K (0.25) using backward difference formula.

m	0.20	0.22	0.24	0.26	0.28	0.30
K(m)	1.659624	1.669850	1.680373	1.691208	1.702374	1.713889

[4+12]

- 4.(a) Solve the differential equation $\frac{dy}{dx} = 1 + xy$ subject to $y(0) = 1$ by Taylor series method and hence find $y(0.2)$.
- (b) Solve the difference equation $y_{n+2} + 3y_{n+1} + 2y_n = 0$, $y_0 = 1$, $y_1 = 2$ by z - transform.

[8+8]

- 5.(a) Find the Fourier series of $f(x) = x + x^2, -\pi < x < \pi$ and hence deduce the series

$$\frac{1}{1^2} - \frac{1}{2^2} + \frac{1}{3^2} - \dots = \frac{\pi^2}{12}$$

- (b) Apply Runge - Kutta Method to find $y(0.1)$ and $y(0.2)$ where $\frac{dy}{dx} = x^2 - y$ and $y(0) = 1$.

[8+8]



- 6.(a) Find the Fourier transform of $e^{-|x|}$
(b) Using Regula Falsi method find a real root of $f(x) = 2x^7 + x^5 + 1 = 0$ correct upto two decimal places.

[8+8]

- 7.(a) Find $z\left(\frac{1}{n!}\right)$ and hence evaluate $z\left(\frac{1}{(n+1)!}\right)$ and $z\left(\frac{1}{(n+2)!}\right)$
(b) Find a real root of $f(x) = x + \log x - 2$ using Newton-Raphson method.

[8+8]

PDFill PDF Editor with Free Writer and Tools



I B.Tech I Semester Supplementary Examinations, Feb/Mar 2014
ENGINEERING PHYSICS-I
 (Common to Civil Engineering, Electrical & Electronics Engineering,
 Mechanical Engineering, Electronics & Communication Engineering,
 Computer Science & Engineering, Chemical Engineering, Electronics &
 Instrumentation Engineering, Bio-Medical Engineering, Information
 Technology, Electronics & Computer Engineering, Aeronautical
 Engineering, Bio-Technology, Automobile Engineering, Mining and
 Petroleum Technology)

Time: 3 hours

Max Marks: 75

Answer any FIVE Questions
 All Questions carry equal marks

1. (a) Explain the interference of light due to thin films.
 (b) What is Coherent Length? Explain [12+3]
2. (a) Explain Rayleigh's criterion of resolution.
 (b) Write a note on resolving power of a grating. [9+6]
3. (a) Discuss the various methods by which polarized light can be produced?
 (b) The refractive index of glass is 1.5. Calculate the Brewster's angle for it. Also calculate the angle of refraction. [9+6]
4. (a) What is Primitive cell? How does it differ from unit cell?
 (b) Illustrate the SC, BCC and FCC crystal structures.
 (c) Write different crystal systems [3+9+3]
5. (a) Explain the principle, procedure and advantage of Debye-Scherrer method of X-ray diffraction.
 (b) Obtain Miller indices of a plane which intercepts at a, b/2 and 3c in simple cubic unit cell. Draw a neat diagram showing the plane. [11+4]
6. (a) What are important characteristics of Laser?
 (b) What are the Scientific, Industrial and Medical applications of Laser?
 (c) What is the role of optical cavity and active medium in a Laser [4+6+5]
7. (a) What are the conditions to produce total internal reflection in optical fiber.
 (b) Describe structure of different types of Optical fibers with ray paths.
 (c) Calculate the angle of acceptance of a given optical fiber, if the refractive indices of the core and the cladding are 1.563 and 1.498 respectively. [3+8+4]
8. (a) Explain the working of Ultrasonic flaw detector.
 (b) Explain three different and most common types of scans used in Ultrasonic inspection. [6+9]



I B.Tech I Semester Supplementary Examinations, Feb/Mar 2014
ENGINEERING PHYSICS-I
(Common to Civil Engineering, Electrical & Electronics Engineering,
Mechanical Engineering, Electronics & Communication Engineering,
Computer Science & Engineering, Chemical Engineering, Electronics &
Instrumentation Engineering, Bio-Medical Engineering, Information
Technology, Electronics & Computer Engineering, Aeronautical
Engineering, Bio-Technology, Automobile Engineering, Mining and
Petroleum Technology)

Time: 3 hours

Max Marks: 75

Answer any FIVE Questions
All Questions carry equal marks

1. (a) State and explain Superposition principle?
(b) With ray diagram discuss the theory of thin films and derive the condition for constructive and destructive interference in the case of reflected system. [3+12]
2. (a) What is meant by diffraction of light? Explain.
(b) What is Rayleigh's Criterion for resolving power?
(c) Define Resolving power of a grating. Derive the expression for Resolving power of a grating based on Rayleigh's Criterion. [3+6+6]
3. (a) What do you mean by Polarisation?
(b) Distinguish between Polarised and Unpolarised lights.
(c) Discuss how the Circular and Elliptical Polarised lights can be produced? [4+5+6]
4. (a) Explain the terms:
(i) Space Lattice (ii) Basis (iii) Unit Cell (iv) Primitive Cell
(b) Write notes on Bravais lattices
(c) Lithium crystallizes in BCC structure. Calculate the lattice constant, given that atomic weight and density of Lithium are 6.94 and 530 kg/m³ respectively. [8+3+4]
5. (a) Derive Bragg's law and obtain the limiting condition for it.
(b) Obtain Miller indices of a plane which intercepts at a, b/2 and 3c in simple cubic unit cell. Draw a neat diagram showing the plane. [11+4]
6. (a) Explain the construction and working of Ruby laser.
(b) What are the differences between Homo junction Laser and Hetero junction Laser? [10+5]

7. (a) Explain how the optical fibers are classified.
(b) Explain the applications of optical fibers
(c) An optical fiber has a numerical aperture of 0.2 and a cladding refractive index of 1.59. Find the acceptance angle for the fiber in water which has a refractive index of 1.33. [6+5+4]
8. (a) Explain the basic principle of ultrasonic testing.
(b) What are the advantages and limitations of ultrasonic testing. [5+10]

PDFill PDF Editor with Free Writer and Tools

I B.Tech I Semester Supplementary Examinations, Feb/Mar 2014
ENGINEERING PHYSICS-I
(Common to Civil Engineering, Electrical & Electronics Engineering,
Mechanical Engineering, Electronics & Communication Engineering,
Computer Science & Engineering, Chemical Engineering, Electronics &
Instrumentation Engineering, Bio-Medical Engineering, Information
Technology, Electronics & Computer Engineering, Aeronautical
Engineering, Bio-Technology, Automobile Engineering, Mining and
Petroleum Technology)

Time: 3 hours

Max Marks: 75

Answer any FIVE Questions
All Questions carry equal marks

1. (a) Discuss the theory of Newton's rings with relevant diagram.
(b) Derive the expression for the diameters of dark and bright rings. [6+8]
2. (a) Describe Fraunhofer diffraction due to single slit.
(b) Describe the action of plane transmission grating in producing diffraction spectrum.
(c) Show that the grating with 500 lines/cm cannot give a spectrum in the 4th order for the light of wavelength 5890. [6+5+4]
3. (a) What is quarter wave plate? Deduce expression for its thickness
(b) Draw a ray diagram for extraordinary and ordinary rays before and after passing through a quarter wave plate.
(c) At what wavelength, the given quarter wave plate of wavelength 600nm will act as half wave plate.
4. (a) Explain the terms 'Unit Cell', 'Basis' and 'Space lattice'.
(b) Obtain the relation between the edge of the unit cell and atomic radius for SC, BCC and FCC lattices.
(c) Chromium has BCC structure. Its atomic radius is 0.1249 nm. Calculate the free volume per unit cell. [3+8+4]
5. (a) What are Miller indices? How are they obtained?
(b) Deduce the expression for the interplanar distance in terms of Miller indices for a cubic system.
(c) Obtain Miller indices of a plane which intercepts at a, b/2 and 3c in simple cubic unit cell. Draw a neat diagram showing the plane. [5+6+4]
6. (a) Distinguish between Spontaneous and Stimulated emissions.
(b) What is the reason for mono chromaticity of laser beam?

- (c) Derive the expression for energy density of radiation in terms of Einstein coefficients. [5+3+7]
7. (a) Define acceptance angle and derive expression for it in terms of fractional index change.
- (b) Write notes on scattering and Absorption loss in the optical fibers. [11+4]
8. (a) What is ultrasonic testing and explain the basic principle?
- (b) What are the properties of Ultrasonic Waves? [10+5]

PDFill PDF Editor with Free Writer and Tools

I B.Tech I Semester Supplementary Examinations, Feb/Mar 2014
ENGINEERING PHYSICS-I
 (Common to Civil Engineering, Electrical & Electronics Engineering,
 Mechanical Engineering, Electronics & Communication Engineering,
 Computer Science & Engineering, Chemical Engineering, Electronics &
 Instrumentation Engineering, Bio-Medical Engineering, Information
 Technology, Electronics & Computer Engineering, Aeronautical
 Engineering, Bio-Technology, Automobile Engineering, Mining and
 Petroleum Technology)

Time: 3 hours

Max Marks: 75

Answer any FIVE Questions
 All Questions carry equal marks

1. (a) Discuss the theory of Newton's rings with relevant diagram.
 (b) Derive the expression for the diameters of dark and bright rings. [6+8]
2. (a) What are the types of diffractions and give the differences between them.
 (b) Obtain the condition for primary maxima in Fraunhofer diffraction due to single slit and derive an expression for width of the central maxima. [5+10]
3. (a) What is meant by Double Refraction?
 (b) Write notes on Optic axis and its characteristics.
 (c) Discuss the construction and action of Nicol prism. [2+5+8]
4. (a) Define Packing fraction and Show that FCC crystals are closely packed than BCC crystals.
 (b) Explain the crystal structures of BCC and FCC crystals. [9+6]
5. (a) Explain how the crystal structure will be determined by Laue method?
 (b) Derive the expression for the Bragg's law. [7+8]
6. (a) Derive Einstein coefficients and explain their significance?
 (b) Describe the construction and working of a semiconductor Laser? [7+8]
7. (a) Describe the construction of an optical fiber and give typical dimensions of various parts.
 (b) Write notes on Attenuation losses in optical fiber communication.
 (c) Calculate the angle of acceptance of a given optical fiber, if the refractive indices of the core and cladding 1.563 and 1.498 respectively. [8+3+4]
8. (a) Discuss various nondestructive testing systems which are commonly adopted in industries using ultrasonics.
 (b) Explain different types of scans in Ultrasonic testing. [7+8]



Subject Code: R13106/R13

Set No - 1

I B. Tech I Semester Regular Examinations Feb./Mar. - 2014

ENVIRONMENTAL STUDIES

(Common to CE, ME, CSE, PCE, IT, Chem E, Aero E, AME, Min E, PE, Metal E)

Time: 3 hours

Max. Marks: 70

Question Paper Consists of **Part-A** and **Part-B**
Answering the question in **Part-A** is Compulsory,
Three Questions should be answered from **Part-B**

PART-A

- 1.(i) What are the causes of floods and droughts?
- (ii) What are ecological pyramids? Write about different types of pyramids
- (iii) Write about different values of biodiversity.
- (iv) Write about Bhopal gas tragedy.
- (v) What is wild life protection act?
- (vi) Write about ecotourism.

[4+4+5+4+3+2]

PART-B

- 2.(a) Define biodiversity. Write about threats of biodiversity.
- (b) Write about EIA, its significance at various stages. [8+8]
- 3.(a) Why should public have awareness about Environmental protection acts?
- (b) What are greenhouse gases?
- (c) Write about rain water harvesting. [6+5+5]
- 4.(a) What is Environmental audit? Explain.
- (b) Write about Grassland ecosystem and Aquatic ecosystem [4+12]
- 5.(a) Write about different types of energy resources.
- (b) What is the role of an individual in conservation of natural resources.
- (c) What are the hot spots of biodiversity? [4+4+8]
- 6.(a) Discuss the causes and effects of global warming
- (b) Distinguish between renewable and non- renewable resources [8+8]
- 7.(a) Mention about different types of pollution briefly.
- (b) Discuss about Environmental ethics and issues connected there on. [6+10]



Subject Code: R13106/R13

Set No - 2

I B. Tech I Semester Regular Examinations Feb./Mar. - 2014

ENVIRONMENTAL STUDIES

(Common to CE, ME, CSE, PCE, IT, Chem E, Aero E, AME, Min E, PE, Metal E)

Time: 3 hours

Max. Marks: 70

Question Paper Consists of **Part-A** and **Part-B**
Answering the question in **Part-A** is Compulsory,
Three Questions should be answered from **Part-B**

PART-A

- 1.(i) Write about soil pollution and causes of soil degradation.
- (ii) Give the salient features of a pond ecosystem
- (iii) What is meant by species Biodiversity?
- (iv) What are the causes of deforestation?
- (v) Write the various stages of EIA.
- (vi) Write a report on any Environmental issue which you have studied.

[4+4+4+3+3+4]

PART-B

- 2.(a) Distinguish between food chain and food web.
- (b) Discuss about EMP (Environmental Management Plan) [8+8]
- 3.(a) What are the three levels of biodiversity?
- (b) Mention about different types of mining and effects of mining? [8+8]
- 4.(a) Name different types of pollution.
- (b) Give an account of energy flow in an ecosystem.
- (c) Write about Environmental Waste Products and their disposal [2+8+6]
- 5.(a) Write about producers, consumers and decomposers.
- (b) What is the extinction of species? Describe the processes which lead to extinction of species. [8+8]
- 6.(a) Discuss the salient features of The environment protection act ,1986.
- (b) Write about greenhouse gases and ozone layer. [8+8]
- 7.(a) Write about role of IT in Environment and human health.
- (b) What is the significance of rain water harvesting?
- (c) Write about ecotourism? [6+6+4]



Subject Code: R13106/R13

Set No - 3

I B. Tech I Semester Regular Examinations Feb./Mar. - 2014

ENVIRONMENTAL STUDIES

(Common to CE, ME, CSE, PCE, IT, Chem E, Aero E, AME, Min E, PE, Metal E)

Time: 3 hours

Max. Marks: 70

Question Paper Consists of **Part-A** and **Part-B**
Answering the question in **Part-A** is Compulsory,
Three Questions should be answered from **Part-B**

PART-A

- 1.(i) Write about structure and function of ecosystem.
- (ii) Write about the sources of water pollution
- (iii) Discuss about benefits of Dam construction.
- (iv) Discuss the problems involved in enforcement of Environmental Legislation.
- (v) Differentiate between endangered and endemic species.
- (vi) Write a note on any polluted site you have visited.

[5+3+4+4+3+3]

PART-B

- 2.(a) Distinguish between deforestation and desertification.
- (b) Write about different energy pyramids. [8+8]
- 3.(a) Explain the process of succession in a newly formed pond.
- (b) Give an account of crisis and conflicts over water. [8+8]
- 4.(a) Name different types of air pollutants and sources of air pollution.
- (b) What are the stages involved in EIP and EIS. [8+8]
- 5.(a) What are the objectives of wild life protection act?
- (b) What do you understand by environmental ethics?
- (c) Discuss various methods of safe disposal of solid waste. [4+4+8]
- 6.(a) What are the major issues and problems related to Resettlement and Rehabilitation of displaced people.
- (b) Write about significance of EIA.
- (c) Write about ecotourism? [8+4+4]
7. Write short note on
- (i) Hot Spots of Biodiversity.
- (ii) Man and Wildlife conflict.
- (iii) Conservation of Biodiversity. [6+5+5]



Subject Code: R13106/R13

Set No - 4

I B. Tech I Semester Regular Examinations Feb./Mar. - 2014

ENVIRONMENTAL STUDIES

(Common to CE, ME, CSE, PCE, IT, Chem E, Aero E, AME, Min E, PE, Metal E)

Time: 3 hours

Max. Marks: 70

Question Paper Consists of **Part-A** and **Part-B**
Answering the question in **Part-A** is Compulsory,
Three Questions should be answered from **Part-B**

PART-A

- 1.(i) Write about the sources of air pollution
- (ii) What are in-situ and ex-situ conservation?
- (iii) Explain the concept of food chain and food web.
- (iv) Write about environmental audit?
- (v) Discuss energy problems related to urban areas.
- (vi) Discuss about conservation of water resources.

[4+5+4+3+3+3]

PART-B

- 2.(a) What is mining? Describe different methods of mining.
- (b) Differentiate between primary succession and secondary succession.
- (c) Write about Nuclear hazards.

[6+6+4]

- 3.(a) Distinguish between renewable and non-renewable resources.
- (b) Discuss about Man induced landslides and its effects with case study.

[6+10]

- 4.(a) What are the sources, effects and control measures of noise pollution.
- (b) What is meant by ozone layer? How CFC'S and ozone depleting substances affect ozone layer?

[8+8]

- 5.(a) Why decomposers are called micro consumers?
- (b) What are the various methods of safe disposal of solid waste?
- (c) Write about desert ecosystem.

[4+8+4]

- 6.(a) What is the significance of EIA and the stages involved
- (b) 'India is a Biodiversity Nation'. Discuss

[8+8]

7. Write short note on
 - (i) Values of Biodiversity
 - (ii) Water Act and Wild life protection Act
 - (iii) Environmental Legislation.

[4+8+4]



ENGINEERING DRAWING

(Common to ECE, EIE, Bio-Tech, EComE, Agri.E)

Time: 3 hours

Max. Marks: 70

Question Paper Consists of Part-A and Part-B
Answering the question in Part-A is Compulsory,
Three Questions should be answered from Part-B

PART-A

1.(a) Draw the isometric view of Fig.1.

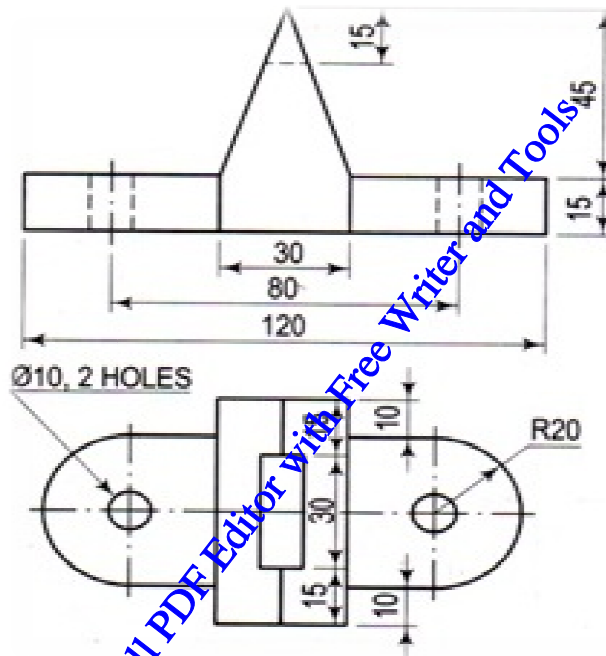

Note: All dimensions are in mm.

Fig.1

(b) Draw the projections of the straight line AB of 100 mm length when one of its ends is touching V.P and the other end is touching HP. The angles of inclination with H.P and V.P are 40° and 50° respectively.

[12+10]

PART-B

2.(a) The area of a field is 50000 sq m. The length and the breadth of the field, on the map is 10 cm and 8 cm respectively. Construct a diagonal scale which can read up to one metre. Mark the length of 235 metre on the scale. What is R.F of the scale?

(b) The foci of an ellipse are 90 mm apart and the minor axis is 72 mm long. Determine the length of the major axis. Construct the ellipse.

[8+8]

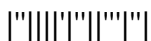

- 3.(a) Two points A and B are in H.P. The point A is 30 mm in front of the V.P while B is behind the V.P. The distance between their projectors is 75 mm and the line joining their top views makes an angle of 45° with xy. Find the distance of the point B from the V.P.
- (b) A line PQ 40 mm long is parallel to V.P and inclined at an angle of 30° to H.P. The lower end P is 15 mm above H.P and 20 mm in front of V.P. Draw the projections of the line. [8+8]
4. The front view of a line AB measures 65 mm and makes an angle of 45° with xy. A is in the H.P and the VT of the line is 15 mm below the H.P. The line is inclined at 30° to the V.P. Draw the projections of AB and find its true length and inclination with the H.P. Also locate its H.T. [16]
5. Draw the projections of the circle of 50 mm diameter resting in the H.P on a point A on the circumference, its plane inclined at 45° to the H.P and
 - (a) The top view of the diameter AB making 30° angle with the V.P
 - (b) The diameter AB making 30° angle with the V.P. [16]
6. Draw the projections of a cylinder 75mm diameter and 100 mm long, lying on the ground with its axis inclined at 30° to the V.P and parallel to the ground. [16]
7. Draw (i) Front view (ii) Side view from the right (iii) Top view of Fig: 2 [16]

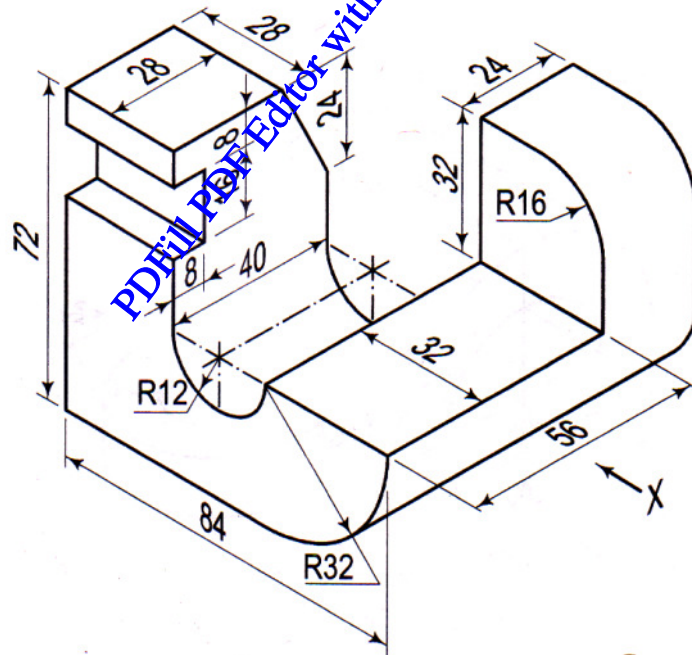

Note: All dimensions are in mm.

Fig: 2

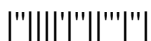

ENGINEERING DRAWING

(Common to ECE, EIE, Bio-Tech, EComE, Agri.E)

Time: 3 hours

Max. Marks: 70

Question Paper Consists of **Part-A** and **Part-B**
Answering the question in **Part-A** is Compulsory,
Three Questions should be answered from **Part-B**

PART-A

1.(a) Draw (i) Front view (ii) Top view of Fig.1.

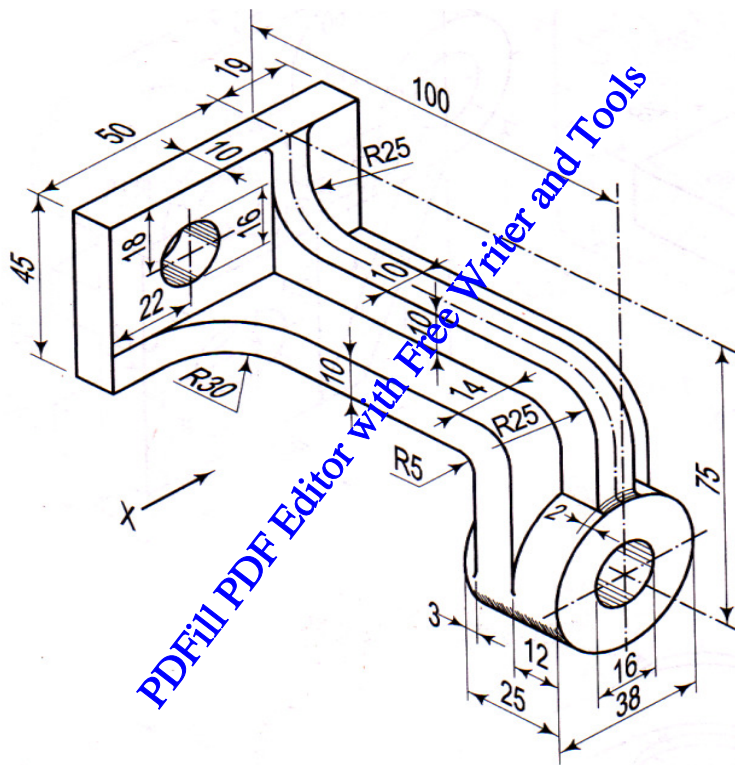

Note: All dimensions are in mm.

Fig.1

(b) A circular plate of negligible thickness and 50 mm diameter appears as an ellipse in the front view, having its major axis 50 mm long and minor axis 30 mm long. Draw its top view when the major axis of the ellipse is horizontal.

[12+10]

PART-B

2.(a) Construct a vernier scale of R.F=1/80 to read inches and to measure up to 15 yards.

(b) Construct a regular hexagon of side 28 mm when one side is horizontal.

[8+8]

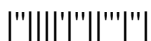

- 3.(a) The top view of a 75 mm long line measures 55 mm. The line is in the V.P, its one end being 25 mm above the H.P. Draw its projections.
- (b) A point P is 15 mm above H.P and 20 mm in front of the V.P. Another point Q is 25 mm behind the V.P and 40 mm below the H.P. Draw projections of P and Q keeping the distance between their projectors equal to 90 mm. Draw straight lines joining (i) their top views and (ii) their front views. [8+8]
4. A line PQ, 100 mm long, is inclined at 45° to the H.P and at 30° to the V.P. Its end P is in the second quadrant and Q is in the fourth quadrant. A point R on PQ, 40 mm from P is in both the planes. Draw the projections of PQ. [16]
5. Draw the projections of a regular hexagon of 25 mm side, having one of its sides in the H.P and inclined at 60° to the V.P and its surface making an angle of 45° with the H.P. [16]
6. Draw the projections of a cone, base 75 mm diameter and axis 100 mm long, lying on the H.P on one of its generators with the axis parallel to the V.P. [16]
7. Draw the isometric view of Fig.2: [16]

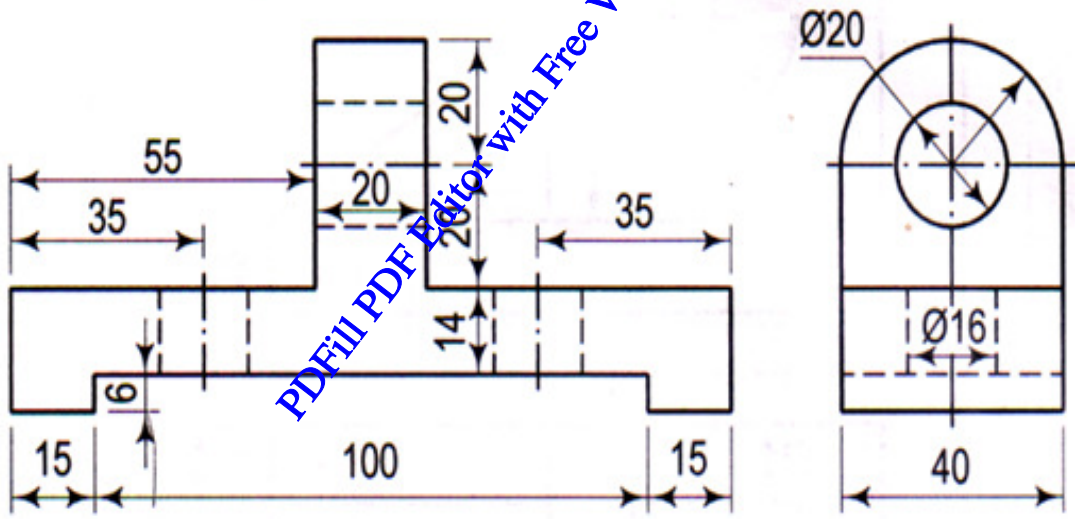

Note: All dimensions are in mm.
Fig.2



ENGINEERING DRAWING

(Common to ECE, EIE, Bio-Tech, EComE, Agri.E)

Time: 3 hours

Max. Marks: 70

Question Paper Consists of Part-A and Part-B
Answering the question in Part-A is Compulsory,
Three Questions should be answered from Part-B

PART-A

1.(a) Draw the isometric view of Fig.1

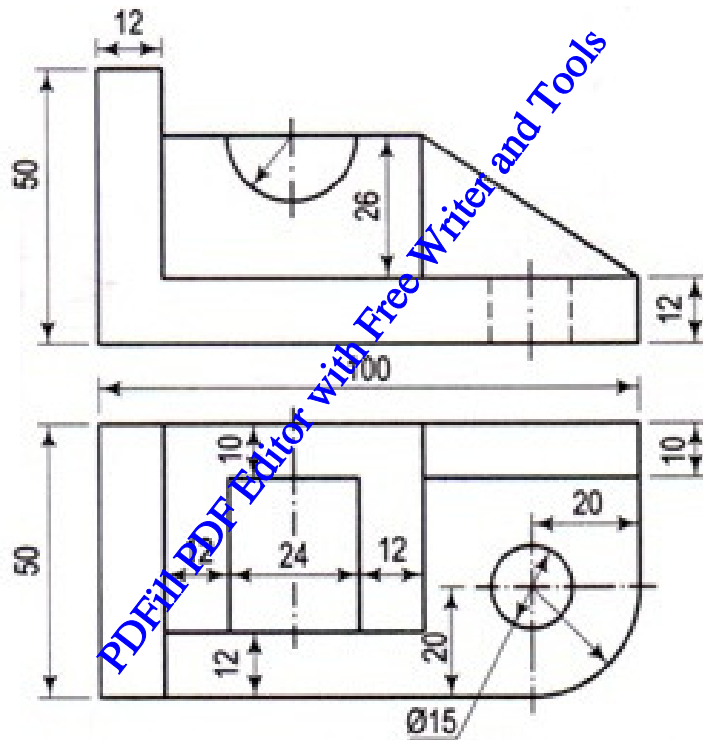

Note: All dimensions are in mm.

Fig.1

(b) A thin circular plate of 70 mm diameter is resting on its circumference such that its plane is inclined 60° to the H.P and 30° to the V.P. Draw the projections of the plate.

[12+10]

PART-B

2. (a) Construct a diagonal scale of R.F=1/4000 to show metres and long enough to measure upto 500 metres.

(b) Construct a regular hexagon of 35 mm side with one of its side vertical?

[10+6]

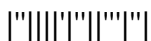

3. (a) The front view of a line inclined at 30° to the V.P is 65 mm long. Draw the projections of the line, when it is parallel to and 40 mm above the H.P, its one end being 30 mm in front of the V.P.
- (b) Mark the projections of the following points on a common reference line, keeping the projectors 35mm apart.
- (i) A, 25mm above H.P and 35mm in front of V.P
 - (ii) B, 25mm above H.P and 40 mm behind V.P
 - (iii) C, 30mm below H.P and 45 mm behind V.P
 - (iv) D, 30 mm below H.P and 40 mm in front V.P
- [8+8]
4. A line AB, 90 mm long, is inclined at 45° to the H.P and its top view makes an angle of 60° with the V.P. The end A is in the H.P and 12 mm in front of the V.P. Draw its front view and find its true inclination with the V.P.
- [16]
5. A square plate PQRS of negligible thickness having 35 mm side is lying on a corner R on H.P. One of the diagonals RP is inclined at 35° to H.P and 40° to V.P. The two sides QR and RS containing the corner R are equally inclined with H.P. Draw its projections.
- [16]
6. A hexagonal pyramid side of base 25 mm axis 50 mm long lies with one of its rectangular faces on the H.P and its axis is parallel to the V.P. Draw its projections.
- [16]
7. Draw (i) Front view and (ii) Top view of Fig.2
- [16]

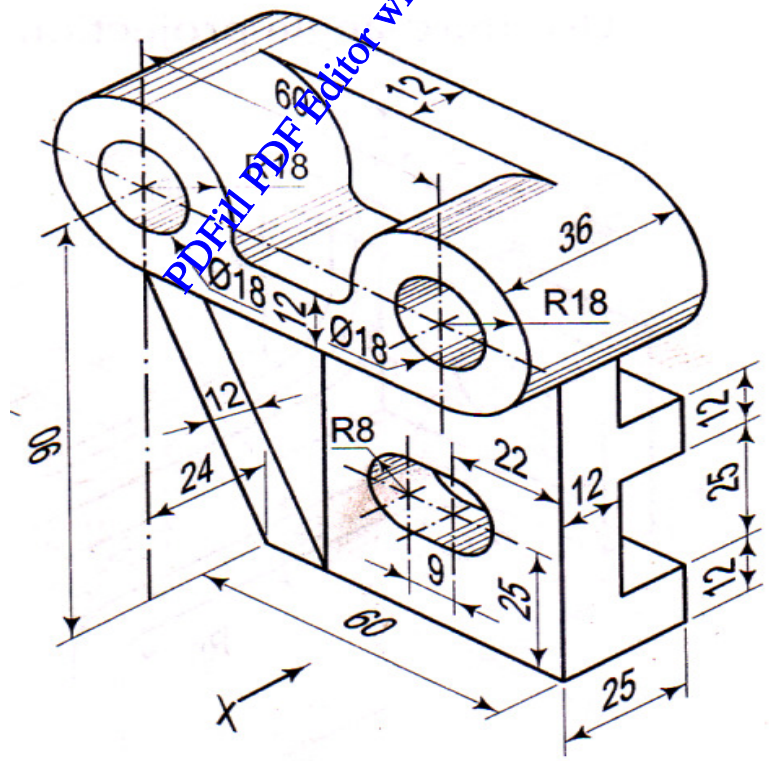

Note: All dimensions are in mm.

Fig.2

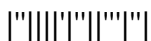

ENGINEERING DRAWING

(Common to ECE, EIE, Bio-Tech, EComE, Agri.E)

Time: 3 hours

Max. Marks: 70

Question Paper Consists of Part-A and Part-B
Answering the question in Part-A is Compulsory,
Three Questions should be answered from Part-B

PART-A

1.(a) Draw (i) front view (ii) side view from the left (iii) top view of Fig.1

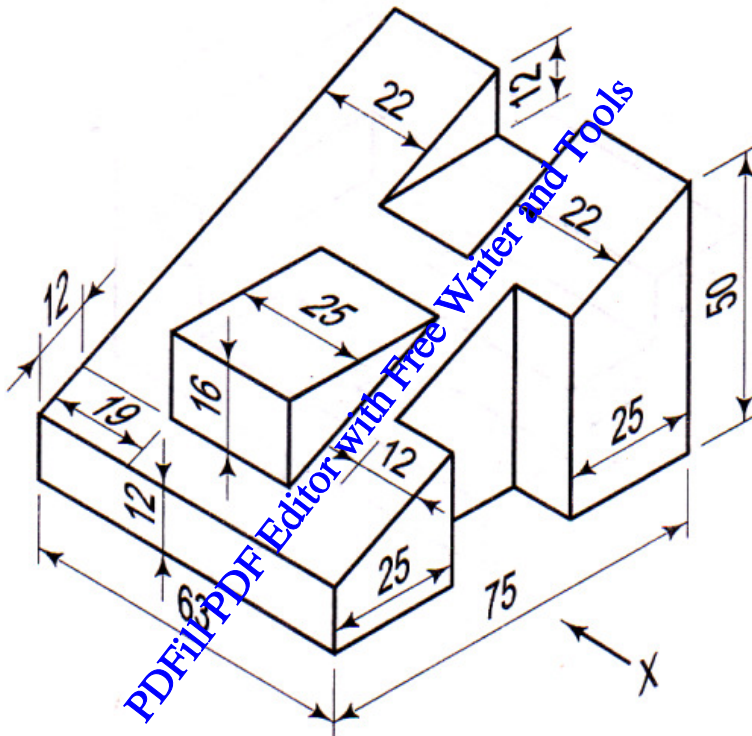

Note: All dimensions are in mm.

Fig.1

(b) A hexagonal prism base 40 mm side and height 40 mm has a hole of 40 mm diameter drilled centrally through its ends. Draw its projections when it is resting on one of its corners on the H.P with its axis inclined at 60 degrees to the H.P and two of its faces parallel to the V.P.

[12+10]

PART-B

2. (a) Construct an ellipse when the major axis is 120 mm and the distance between the foci is 108 mm. Determine the length of the minor axis.

(b) Draw a vernier scale of R.F = 1/25 to read centimeters up to 4 metres and on it, show lengths representing 2.39 m and 0.91 m.

[8+8]



3. Two pegs fixed on a wall are 4.5 metres apart. The distance between the pegs measured parallel to the floor is 3.6 metres. If one peg is 1.5 m above the floor, find the height of the second peg and the inclination of the line joining the two pegs with the floor. [16]
4. A line CD inclined at 25° to H.P measures 80 mm in top view. End C in the first quadrant and 25 mm and 15 mm from H.P and V.P respectively. End D is at equal distances from both the reference planes. Draw the projections; find true length and true inclination with V.P. Locate the traces. [16]
5. A 60° set-square of 125 mm longest side is so kept that the longest side in the H.P making an angle of 30° with the V.P and the set-square itself inclined at 45° to the H.P. Draw the projections of the set- square. [16]
6. Draw the projections of a pentagonal pyramid of base 25 mm side and axis 60 mm long when it is lying on H.P on one of its base edges, such that the axis is parallel to VP and inclined at 30° to HP. [16]
7. Draw the isometric view of Fig.2: [16]

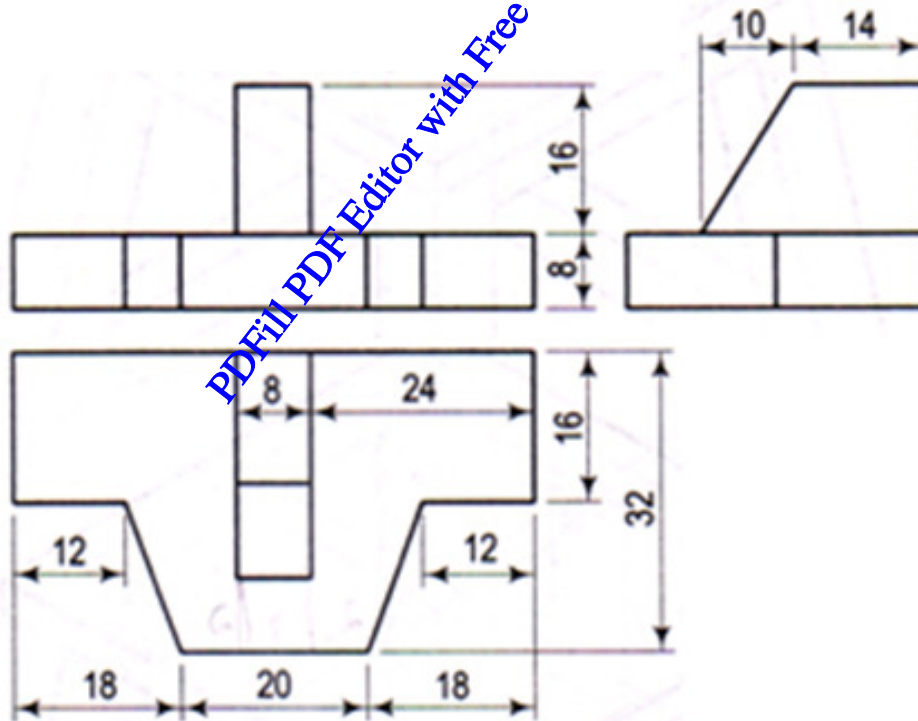

Note: All dimensions are in mm.
Fig. 2.



I B.Tech I Semester Supplementary Examinations, Feb/Mar 2014
ENVIRONMENTAL STUDIES

(Common to Mechanical Engineering, Electronics & Communication
Engineering, Chemical Engineering, Information Technology, Electronics &
Computer Engineering, Mining and Petroleum Technology)

Time: 3 hours

Max Marks: 75

Answer any FIVE Questions
All Questions carry equal marks

1. Critically discuss what are the important objectives and the guiding principles of environmental studies? [15]
2. Discuss the reasons for land degradation and suggest steps to control it and explain what is Soil management, Shifting cultivation, Desertification and Man induced landslides. [15]
3. (a) Define ecosystem? and types of ecosystems in the nature.
(b) What are the general characteristics of an ecosystem? [8+7]
4. (a) Name a few birds and their contribution to the environment?
(b) What are the ecological services rendered by forests? Cite the examples of aesthetic, recreational, economic, historical, cultural and religious values of forest around your place. [5+10]
5. (a) How does marine pollution occur?
(b) What are the International activities to control marine pollution? [8+7]
6. (a) What are the powers provided to the central Government by the Environmental Protection Act, 1986?
(b) Write short note on environmental victims and their rehabilitation? [8+7]
7. (a) what is the Maximum carrying capacity and Exponential growth of population? Explain?
(b) what is your role for control of diseases in your local region? [8+7]
8. (a) Explain the types of components that are present in the solid waste material.
(b) What are the types of observations you find when you visited the polluted and non polluted zone. [8+7]

I B.Tech I Semester Supplementary Examinations, Feb/Mar 2014
ENVIRONMENTAL STUDIES

(Common to Mechanical Engineering, Electronics & Communication
Engineering, Chemical Engineering, Information Technology, Electronics &
Computer Engineering, Mining and Petroleum Technology)

Time: 3 hours

Max Marks: 75

Answer any FIVE Questions
All Questions carry equal marks

1. Describe the guiding principles of environmental education? Give an account of formal and non-formal environmental education being imparted in India? [15]
2. (a) Is it necessary to construct multipurpose dams? If not suggest alternatives and discuss the impact of dams on forests and tribal people?
(b) Discuss any two case studies of people's movement against construction of dams. [8+7]
3. (a) What roles do autotrophs and heterotrophs play in the ecosystem?
(b) Explain the process of a succession in a newly formed pond ecosystem. [8+7]
4. (a) What are the major biogeographical regions in India.
(b) Enumerate the biosphere reserves of India. [8+7]
5. (a) How to control thermal pollution in Industries?
(b) Define noise pollution? How noise pollution can be controlled? [7+8]
6. (a) Discuss the salient features of Wild life (protection) Act, 1972
(b) Discuss the salient features of Forest (conservation) Act, 1980 [8+7]
7. (a) What do you mean by "Slum"? What kind of shelter does it provide?
(b) What are the objectives of UDHR by the United Nations? [8+7]
8. (a) Explain the types of components which are present in the solid waste material.
(b) What are the types of observations you find when you visited a polluted and non polluted zone. [8+7]



I B.Tech I Semester Supplementary Examinations, Feb/Mar 2014
ENVIRONMENTAL STUDIES

(Common to Mechanical Engineering, Electronics & Communication Engineering, Chemical Engineering, Information Technology, Electronics & Computer Engineering, Mining and Petroleum Technology)

Time: 3 hours

Max Marks: 75

Answer any FIVE Questions
All Questions carry equal marks

1. Write a detailed note on the various governmental institutions and organizations in the field of public awareness and preservation of natural assets? [15]
2. Explain the use of solar energy for the purpose of Solar water heating, Solar cooking, Solar electric power generation, Solar green houses and Solar drying of agriculture animal products. [15]
3. Write note on:
 - (a) Nitrogen cycle
 - (b) Carbon cycle
 - (c) Hydrological cycle [5+5+5]
4. (a) Explain how the study of biodiversity is beneficial to human life.
(b) Explain about consumptive value of biodiversity. [8+7]
5. (a) How does degradation of pesticides take place in soil?
(b) What are the effects of using synthetic pesticides? [8+7]
6. (a) Do you think moral values prevent pollution in the environment? Explain your view?
(b) Define climate change? Explain the sources and effects of Global warming? [8+7]
7. Write notes on the following social security measures
 - (a) Life insurance
 - (b) Public Provident Fund
 - (c) Categorical benefits
 - (d) Employee's provident fund [5+5+5]
8. (a) What are the types forests in India? Define them and give proper examples.
(b) What is the role of river water in preparing the EIA report for an Industry? [8+7]

I B.Tech I Semester Supplementary Examinations, Feb/Mar 2014
ENVIRONMENTAL STUDIES

(Common to Mechanical Engineering, Electronics & Communication
Engineering, Chemical Engineering, Information Technology, Electronics &
Computer Engineering, Mining and Petroleum Technology)

Time: 3 hours

Max Marks: 75

Answer any FIVE Questions
All Questions carry equal marks

1. (a) Describe the various conservation practices followed in the society and by individuals for preservation of environmental assets?
(b) Explain about "Urjagram and Model villages". [8+7]
2. (a) Explain selective felling and what are the negative impacts of timber extraction? Explain what measures need to be taken for conserving forest wealth?
(b) "Forests act as factories of soils and often called as Earth lungs". Explain the statement. [8+7]
3. (a) What are decomposers? Explain their role in the ecosystem.
(b) Discuss the major feature of a stream (river) that differs from that of a lake. [7+8]
4. (a) Explain about In-situ conservation of biodiversity.
(b) What is the medicinal value of biodiversity? [8+7]
5. (a) How is liquid waste managed?
(b) How municipal waste is handled in Indian cities and towns? [8+7]
6. (a) What are the objectives of Environmental Impact Assessment(EIA)?
(b) write short notes on
(i)Polluter pays principle(PPP)?
(ii)Carbon Trading [8+7]
7. Write the following
(a) occupational health hazards
(b) water born diseases
(c) Air born diseases [5+5+5]
8. (a) What are the types of farming carried out by tribal culture and explain the effects of such farming on mountains.
(b) What are differences you observe between the Eco Tourism Park and normal amusement park. [8+7]

I B.Tech I Semester Supplementary Examinations, Feb/Mar 2014
MATHEMATICAL METHODS
 (Common to Civil Engineering, Electrical & Electronics Engineering,
 Computer Science & Engineering, Electronics & Instrumentation
 Engineering, Aeronautical Engineering, Bio-Technology and Automobile
 Engineering)

Time: 3 hours

Max Marks: 75

Answer any FIVE Questions
 All Questions carry equal marks

1. (a) Find value of K if rank of A is 3, if $A = \begin{bmatrix} 1 & 2 & -1 & 3 \\ 4 & 1 & 2 & 1 \\ 3 & 1 & 1 & 2 \\ 1 & 2 & 0 & K \end{bmatrix}$
- (b) Solve by Gauss elimination method $10x+y+z=12$; $2x+10y+z=13$; $x+y+5z=7$; [7+8]
2. (a) Prove that the Eigen values of a triangular matrix are diagonal elements of the matrix
- (b) Find eigen vectors of $B=2A^2 + 3I$ when $A = \begin{bmatrix} 8 & -4 \\ 2 & 2 \end{bmatrix}$ [5+10]
3. Define the nature of the quadratic form. Identify the nature of the quadratic form $x_1^2 + 4x_2^2 + x_3^2 - 4x_1x_2 + 2x_1x_3 + 4x_2x_3$ [15]
4. (a) Evaluate the real root of the equation $x^2 - 9x + 1 = 0$ by Bisection method
- (b) Compute the real root of the equation $x^3 - x^2 - 1 = 0$ by the method of false position. [8+7]
5. (a) Compute the approximate value of e^{-x} when $x= 1.7489$ from the following table using the Gauss forward interpolation formula.

x	1.72	1.73	1.74	1.75	1.76	1.77	1.78
e^{-x}	0.179066	0.177284	0.175520	0.173774	0.172045	0.170333	0.168638

- (b) Find the Parabola passing through the points (0, 1), (1,3) and (3,5), Using Lagrange's Interpolation formula. [8+7]
6. (a) Find the first and second derivatives of the function tabulated below at the point $x = 1.5$.

X	1.5	2.0	2.5	3.0	3.5	4.0
Y	3.375	7.0	13.625	24.0	38.875	59.0

- (b) Evaluate $\int_{0.6}^{2.0} y dx$ using Trapezoidal, Simpsons 1/3 and Simpsons 3/8 rules.

X	0.6	0.8	1.0	1.2	1.4	1.6	1.8	2.0
y	1.23	1.58	2.03	4.32	6.25	8.38	10.23	12.45

[8+7]

7. (a) Solve $y' = 3x + y/2$, $y(0) = 1$ by Taylor series method and hence find $y(0.1)$, $y(0.2)$
- (b) Solve the equation $\frac{dy}{dx} = xy + 1$, $y(0) = 1$ by Picard's method and hence find $y(0.1)$ [8+7]
8. (a) Fit a least square parabola $y = a + bx + cx^2$ to the following data

x	-3	-2	-1	0	1	2	3
y	4.63	2.11	0.67	0.09	0.63	2.15	4.58

- (b) Fit a straight line of the form $y = a + bx$ to the following data

x	1	2	4	5	6	8	9
y	2	5	7	10	14	15	19

[7+8]

PDFill PDF Editor with Free Writer and Tools



I B.Tech I Semester Supplementary Examinations, Feb/Mar 2014
MATHEMATICAL METHODS
 (Common to Civil Engineering, Electrical & Electronics Engineering,
 Computer Science & Engineering, Electronics & Instrumentation
 Engineering, Aeronautical Engineering, Bio-Technology and Automobile
 Engineering)

Time: 3 hours

Max Marks: 75

Answer any FIVE Questions
 All Questions carry equal marks

1. (a) Find rank of $A = \begin{bmatrix} 2 & 1 & 3 & 1 \\ 0 & 1 & 2 & -2 \\ 4 & 0 & 2 & 6 \end{bmatrix}$ using Normal Form
- (b) Solve by Gauss seidal method $x+4y+15z=24$, $x+12y+z=26$, $10x+y-2z=10$ [7+8]
2. (a) Find Eigen Vectors of $\begin{bmatrix} 5 & 4 \\ 1 & 2 \end{bmatrix}$
- (b) If λ is an Eigen value of A then prove that $\frac{|A|}{\lambda}$ is an Eigen value of Adj. A [7+8]
3. Find the rank, signature and index of the quadratic form $2x_1^2 + x_2^2 - 3x_3^2 + 12x_1x_2 - 4x_1x_3 - 8x_2x_3$ by reducing it to normal form .Also write the linear transformation which brings about the normal reduction [15]
4. (a) Using Newton- Raphson's method compute $\sqrt{41}$ correct to four decimal places.
- (b) Find a real root of the equation $e^x = x+2$ in the interval $[1, 1.4]$ using bisection method. [8+7]
5. (a) Apply Gauss backward interpolation formula to find y when x = 26 from the following table:
- | | | | | |
|---|------|------|------|------|
| x | 20 | 24 | 28 | 32 |
| Y | 2854 | 3162 | 3544 | 3992 |
- (b) Using Lagrange's interpolation formula, find the value of y when x = 2 from the following data:
- | | | | | |
|---|---|----|----|-----|
| x | 1 | 3 | 4 | 6 |
| y | 4 | 40 | 85 | 259 |
- [8+7]
6. (a) Find the value of $f'(x)$ at $x=0.01$ from the following table using Bessel's formula.
- | | | | | | | |
|------|--------|--------|--------|--------|--------|--------|
| x | 0.01 | 0.02 | 0.03 | 0.04 | 0.05 | 0.06 |
| f(x) | 0.1023 | 0.1047 | 0.1071 | 0.1096 | 0.1122 | 0.1148 |
- (b) Find the area bounded by the curve $y = e^{-\frac{x^2}{2}}$, x - axis between $x = 0$ and $x = 3$ by using Simpson's 3/8 rule. [8+7]

7. (a) Solve $y' = x - y$, $y(0) = 1$ by modified Euler's method and find $y(0.1)$, $y(0.2)$
(b) Apply third order R-K method to find $y(0.25)$ where $y' = 1 + xy$, $y(0) = 1$ [8+7]

8. (a) Fit a power curve $y = ax^b$ to the following data

x	5	6	7	8	9	10
y	133	55	23	7	2	2

- (b) Fit a curve of the type $y = a + bx + cx^2$ to the following data

x	0	1	2	3	4	5	6
y	14	18	23	29	36	40	46

[7+8]

PDFill PDF Editor with Free Writer and Tools

I B.Tech I Semester Supplementary Examinations, Feb/Mar 2014
MATHEMATICAL METHODS
 (Common to Civil Engineering, Electrical & Electronics Engineering,
 Computer Science & Engineering, Electronics & Instrumentation
 Engineering, Aeronautical Engineering, Bio-Technology and Automobile
 Engineering)

Time: 3 hours

Max Marks: 75

Answer any FIVE Questions
 All Questions carry equal marks

1. (a) Find rank using Normal Form $A = \begin{bmatrix} 1 & 2 & 3 & 0 \\ 2 & 4 & 3 & 2 \\ 3 & 2 & 1 & 3 \\ 6 & 8 & 7 & 5 \end{bmatrix}$
- (b) Solve Homogeneous equations $x_1+2x_2+3x_3=0$, $2x_1+3x_2+x_3=0$,
 $4x_1+5x_2+4x_3=0$, $X_1+x_2-2x_3=0$ [7+8]
2. (a) Find Eigen values and Eigen vectors of $\begin{bmatrix} 8 & 4 \\ 2 & 2 \end{bmatrix}$
- (b) If λ is an Eigen value of A then prove that λ^{-1} is an Eigen value of A^{-1} if it exists [7+8]
3. Find the rank, signature and index of the quadratic form $2x_1^2 + x_2^2 - 3x_3^2 + 12x_1x_2 - 4x_1x_3 - 8x_2x_3$ by reducing it to normal form. Also write the linear transformation which brings about the normal reduction [15]
4. (a) Find out square root of 25 given $x_0=2$, $x_1=7$ using Bisection method
- (b) Solve the equation $x^3 + 2x^2 + 10x = 20$ by iteration method [8+7]
5. (a) Use gauss forward interpolation formula to estimate $f(32)$, given $f(25) = 0.2707$, $f(30) = 0.3027$, $f(35) = 0.3386$, $f(40) = 0.3794$.
- (b) Find the interpolating polynomial $f(x)$ from the table given below.
- | | | | | |
|------|---|---|----|----|
| x | 0 | 1 | 4 | 5 |
| f(x) | 4 | 3 | 24 | 39 |
- [8+7]
6. (a) Using the table below, find $f'(0)$
- | | | | | | | |
|------|---|----|----|-----|-----|-----|
| x | 0 | 2 | 3 | 4 | 7 | 9 |
| f(x) | 4 | 26 | 58 | 110 | 460 | 920 |
- (b) Evaluate $\int_0^1 \sqrt{1+x^3} dx$ taking $h = 0.1$ using Simpson's 3/8th rule. [8+7]
7. (a) Solve $y^1=x+y$ subject to the condition $y(0)=1$ by Taylor series method and hence find $y(0.2)$, $y(0.4)$
- (b) Solve $y^1=x-y$, $y(0)=1$ by Picard's method and hence find y at $x=0.2$ [8+7]

8. (a) Fit a curve of the type
- $y = a + bx + cx^2$
- to the following data

x	10	15	20	25	30	35
y	35.3	32.4	29.2	26.1	23.2	20.5

- (b) Fit a curve of the type
- $y = ab^x$
- to the following data by the method of least squares

x	1	2	5	10	20	30	40	50
Y	98.2	91.7	81.3	64	36.4	32.6	7.1	11.3

[7+8]

PDFill PDF Editor with Free Writer and Tools

I B.Tech I Semester Supplementary Examinations, Feb/Mar 2014
MATHEMATICAL METHODS
 (Common to Civil Engineering, Electrical & Electronics Engineering,
 Computer Science & Engineering, Electronics & Instrumentation
 Engineering, Aeronautical Engineering, Bio-Technology and Automobile
 Engineering)

Time: 3 hours

Max Marks: 75

Answer any FIVE Questions
 All Questions carry equal marks

1. (a) Find rank of matrix using Normal form $A = \begin{bmatrix} 1 & 2 & 3 & -2 \\ 2 & -2 & 1 & 3 \\ 0 & 4 & 1 & 1 \end{bmatrix}$
- (b) Solve system of equations, if consistent $2x+y+z=2$, $x+2y+z=2$, $4x-7y-5z=2$ [7+8]
2. Verify Cayley - Hamilton theorem and find A^{-1} if $A = \begin{bmatrix} 2 & -1 & 2 \\ -1 & 2 & -1 \\ 1 & -1 & 2 \end{bmatrix}$ [15]
3. Reduce the quadratic form to canonical form by an orthogonal reduction and state the nature of the quadratic form $5x^2 + 26y^2 + 6xy + 4yz + 14zx$. Also find its rank signature and index. [15]
4. (a) Using Newton-Raphson's method find the square root of a number and hence find the square root of 24.
- (b) Find a real root of the equation $x=e^{-x}$, using Bisection method [8+7]
5. (a) Apply Gauss's forward formula to find $f(x)$ at $x = 3.5$ from the table below.
- | | | | | |
|------|-------|-------|-------|-------|
| X | 2 | 3 | 4 | 5 |
| F(x) | 2.626 | 3.454 | 4.784 | 6.986 |
- (b) Find $\sin 45^\circ$ using Gauss's backward interpolation formula given that $\sin 20^\circ = 0.342$, $\sin 30^\circ = 0.502$, $\sin 40^\circ = 0.642$, $\sin 50^\circ = 0.766$, $\sin 60^\circ = 0.866$, $\sin 70^\circ = 0.939$, $\sin 80^\circ = 0.984$. [8+7]
6. (a) Given the following table. Find $f'(1)$ and $f''(3)$
- | | | | | | |
|------|---|----|----|-----|-----|
| x | 0 | 2 | 4 | 6 | 8 |
| f(x) | 7 | 13 | 43 | 145 | 367 |
- (b) Find approximate value of $\int_1^{1.04} f(x)dx$ using the following table.
- | | | | | | |
|------|-------|-------|-------|-------|-------|
| x | 1 | 1.01 | 1.02 | 1.03 | 1.04 |
| f(x) | 3.953 | 4.066 | 4.182 | 4.300 | 4.421 |
- [8+7]
7. (a) Given that $\frac{dy}{dx} = \frac{(1+x^2)y^2}{2}$, $y(0)=1$, $y(0.1)=1.06$, $y(0.2)=1.12$, $y(0.3)=1.21$ then evaluate $y(0.4)$ by Milne's predictor corrector method

(b) Solve $\frac{dy}{dx} = \frac{y-x}{y+x}$, $y(0) = 1$ estimate $y(0.1)$ and $y(0.2)$ using Euler's method in 5 steps [8+7]

8. (a) Fit a least square parabola $y = a + bx + cx^2$ to the following data

x	1	2	3	4	5
y	5	12	25	44	69

(b) Fit a straight line of the form $y = a + bx$ to the following data

x	1	2	3	4	5
y	5	12	26	60	90

[8+7]

PDFill PDF Editor with Free Writer and Tools

Subject Code: R13101/R13

Set No - 1

I B. Tech I Semester Regular Examinations Feb./Mar. - 2014

ENGLISH-I

(Common to All Branches)

Time: 3 hours

Max. Marks: 70

Question Paper Consists of **Part-A** and **Part-B**
Answering the question in **Part-A** is Compulsory,
Three Questions should be answered from **Part-B**

PART-A

- 1.(i) What does societal transformation result in?
 - (ii) What is L.A Hill's advice regarding the need to improve step by step thought?
 - (iii) What is a temperature belt?
 - (iv) What made Gandhi to think that he had to economize?
 - (v) How did the clergyman help Scoresby at school?
 - (vi) Bring out the difference between an average man and a scientist.
 - (vii) Explain the problem that Russell says is stark, dreadful and inescapable?
- [3+3+3+3+3+3+4]

PART-B

- 2.(a) "A writer ought to be a good reader in order to be a good writer". Elaborate Hill's views.
- (b) Give an account of achievements of Gopinath. [8+8]
- 3.(a) Write about the universe as described by James Jeans.
- (b) What are the circumstances under which super computer, generations & C-DAC started in India. [8+8]
- 4.(a) Describe the clergyman's character.
- (b) Why was Naidu called the 'Edison of India'? [8+8]
- 5.(a) Write a summary of the essay 'The Scientific Point of View'.
- (b) "We should make way for the youngsters instead of expecting them to come around to our ways". Do you agree with Sudha Murthy's statement? Give reasons. [8+8]
- 6.(a) What are the different phases of transformation in Gandhiji is life of London?
- (b) Write an essay on 'Gender Discrimination'. [8+8]

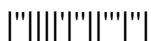

- 7.(a) Write the Synonyms for the following words.
- (i) emulate
 - (ii) infatuation
 - (iii) disbursed
 - (iv) consent
- (b) Write the Antonyms for the following words.
- (i) abstract
 - (ii) impartial
 - (iii) natural
 - (iv) elaborate
- (c) Fill in the blanks with suitable Prepositions.
- (i) Kiran lives ----- 35 James street
 - (ii) He goes to his office ----- bus.
 - (iii) They are angry ----- you
 - (iv) I saw him ----- Sunday
- (d) Correct and rewriter the following sentences.
- (i) Every boy and every girl have to participate in the competition.
 - (ii) The property was shared among the two brothers.
 - (iii) I am reading a interesting story.
 - (iv) The boy was playing while it is raining.

[4+4+4+4]

PDFill PDF Editor with Free Writer and Tools



Subject Code: R13101/R13

Set No - 2

I B. Tech I Semester Regular Examinations Feb./Mar. - 2014

ENGLISH-I

(Common to All Branches)

Time: 3 hours

Max. Marks: 70

Question Paper Consists of **Part-A** and **Part-B**
Answering the question in **Part-A** is Compulsory,
Three Questions should be answered from **Part-B**

PART-A

- 1.(i) What does Russell want the public to realize the facts about hydrogen bombs?
 - (ii) What are the biological effects of American civil war on the negro population? What are the causes for it according to Haldane?
 - (iii) How should a writer improve vocabulary?
 - (iv) How did the world change during the last century according to Dr.Kalam?
 - (v) Why did the clergyman join Scoresby in the war?
 - (vi) What is the message of the fable that Gandhi referred?
 - (vii) How does the author describe the future of humanity in the lesson 'The Dying Sun'?
- [3+3+3+3+3+3+4]

PART-B

- 2.(a) Comment on L.A.Hills views on "The Principles of Good Writing".
 - (b) How did Gopinath influence the airline industry?
- [8+8]
- 3.(a) What are the two accidents described by James Jeans? Describe them.
 - (b) Mention Sudha Murthy's achievements.
- [8+8]
- 4.(a) Describe the participation of Scoresby in the war.
 - (b) What was Naidu's relationship with agriculture?
- [8+8]
- 5.(a) How does science affect the opinions of an average man? Explain the views of Haldane.
 - (b) What does India need to do to stay ahead in the global supercomputer race according to Dr.Bhatkar?
- [8+8]
- 6.(a) "But hence forward I became a student" What does Gandhi mean by saying so?
 - (b) Write an essay on 'Misuse of Technology'.
- [8+8]



- 7.(a) Write the Synonyms for the following words.
- (i) genuine
 - (ii) endangered
 - (iii) frequent
 - (iv) prolonged
- (b) Write the Antonyms for the following words.
- (i) wild
 - (ii) mortal
 - (iii) truce
 - (iv) unsurpassed
- (c) Fill in the blanks with suitable Prepositions.
- (i) He always argues ----- the teacher.
 - (ii) The college is open -----9 A.m. to 5 P.M.
 - (iii) She is thirsty ----- knowledge.
 - (iv) They visited us -----June.
- (d) Correct and rewrite the following sentences.
- (i) I was at time for the presentation.
 - (ii) He returned back from Germany last year.
 - (iii) I am hearing the music.
 - (iv) He is a honorable man.

[4+4+4+4]

PDFill PDF Editor with Free Writer and Tools



Subject Code: R13101/R13

Set No - 3

I B. Tech I Semester Regular Examinations Feb./Mar. - 2014

ENGLISH-I

(Common to All Branches)

Time: 3 hours

Max. Marks: 70

Question Paper Consists of **Part-A** and **Part-B**
Answering the question in **Part-A** is Compulsory,
Three Questions should be answered from **Part-B**

PART-A

- 1.(i) What are the areas that can help India change into a knowledge society?
- (ii) How is that a scientist is a curious mixture of pride and humility according to Haldane.
- (iii) How does James Jeans describe the vastness of the universe?
- (iv) Describe what Russell wants the Neutrals to do?
- (v) How did the clergyman feel when Scoresby was elected as the captain of marching regiment ?
- (vi) What efforts did Gandhi make to adapt himself to London lifestyle?
- (vii) Where can an author get the topics to write according to L.A.Hill?

[3+3+3+3+3+3+4]

PART-B

- 2.(a) What does a common man think about science? How does it differ from Haldane's opinion?
- (b) What was the defining moment of Naidu's life? [8+8]
- 3.(a) Why does James Jeans say that the sun is dying? How can physical science help us in such a situation?
- (b) How did Dr.Bhatkar help develop IT field in India? [8+8]
- 4.(a) "A writer should be a good reader and a keen observer"-Do you agree with L.A.Hills views? Give reasons.
- (b) What were the different fields Gopinath entered into? [8+8]
- 5.(a) Describe any of the blunders that you or any one you know has made, which actually helped the situation instead of spoiling it.
- (b) How was Infosys started? How did it change Sudha Murthy's life? [8+8]
- 6.(a) What problems are involved in making Abdul Kalam's dream come to reality?
- (b) Write an essay on 'The Role of Media in Education'. [8+8]



- 7.(a) Write the Synonyms for the following words.
- (i) eliminate
 - (ii) astonishment
 - (iii) peasant
 - (iv) swear
- (b) Write the Antonyms for the following words.
- (i) rare
 - (ii) depart
 - (iii) natural
 - (iv) vivid
- (c) Fill in the blanks with suitable Prepositions.
- (i) He is not responsible ----- this.
 - (ii) I have been living here ----- 1986.
 - (iii) The boy travels ----- bus
 - (iv) The principal congratulated the team ----- their success.
- (d) Correct and rewrite the following sentences.
- (i) He is a honest man.
 - (ii) We discussed about the matter.
 - (iii) Each of the boys get a prize.
 - (iv) They enjoyed the picnic very much.

[4+4+4+4]

PDFill PDF Editor with Free Writer and Tools



Subject Code: R13101/R13

Set No - 4

I B. Tech I Semester Regular Examinations Feb./Mar. - 2014

ENGLISH-I

(Common to All Branches)

Time: 3 hours

Max. Marks: 70

Question Paper Consists of **Part-A** and **Part-B**
Answering the question in **Part-A** is Compulsory,
Three Questions should be answered from **Part-B**

PART-A

- 1.(i) How did the Earth come into existence according to James Jeans?
- (ii) How much importance does the L.A.Hill give for inspiration to become a writer?
- (iii) Why do you think Gandhi wants every youth to learn from him about saving money.
- (iv) What does Haldane wants to tell us by giving the example of American Negroes.
- (v) What is the problem that the Russell says is stark, dreadful and inescapable?
- (vi) What and how are the blunders of Scoresby interpreted by others in the war?
- (vii) What are the areas which can help India change into a knowledge super power?

[3+3+3+3+3+3+4]

PART-B

- 2.(a) What according to Abdul Kalam should be done to generate wealth in India?
(b) Give an account of the work done by Sridha Murthy as a philanthropist. [8+8]
- 3.(a) Summarize the suggestions offered by Russell to nations as well as the general public for the maintenance of world peace?
(b) What did Naidu do with the motor cycle after the British surveyor gifted it to him? What were his other achievements? [8+8]
- 4.(a) Write about Scoresby's character.
(b) Give an account of the letter written by the headmaster to the ministry of defense in Delhi. How did that letter change the life of Gopinath? [8+8]
- 5.(a) What are the views expressed by Haldane about Science and its effects?
(b) What were the path breaking initiatives that Dr.Bhatkar led? [8+8]
- 6.(a) Comment on Hill's views about good writing and write about his suggestions for aspiring writers.
(b) Write an essay on 'Socialism'. [8+8]

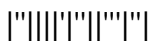

- 7.(a) Write the Synonyms for the following words.
- (i) humility
 - (ii) frequent
 - (iii) lynching
 - (iv) pursuit
- (b) Write the Antonyms for the following words.
- (i) orthodox
 - (ii) hastily
 - (iii) arbitrary
 - (iv) vivid
- (c) Fill in the blanks with suitable Prepositions.
- (i) The house is made -----wood.
 - (ii) He apologized ----- his behavior in the party
 - (iii) This solution is not clear-----me
 - (iv) He is curious -----many things.
- (d) Correct and rewrite the following sentences.
- (i) The price of mangoes are high.
 - (ii) He went to school just now.
 - (iii) One must love his country.
 - (iv) John is an university student.

[4+4+4+4]

PDFill PDF Editor with Free Writer and Tools



Subject Code : R10101/R10

(2012-13 Batch)

Set No - 1

I B.Tech I Semester Supplementary Examinations Feb./Mar. - 2014

ENGLISH – I

(Common to All Branches)

Time: 3 hours

Max. Marks : 75

Answer any FIVE Questions
All Questions carry equal marks

* * * * *

- 1.(a) What were the efforts made by 'Gandhi' to lead a simple Indian life in London?
(b) Give the synonyms for the following words:
(i) destiny (ii) nursery (iii) ruinous (iv) tedious (v) eradication [10+5]
- 2.(a) "There is more satisfaction in rational saving than an irrational spending." Substantiate this view of P.T.Barnum.
(b) Give the antonyms for the following words:
(i) suppress (ii) rivals (iii) cheerful (iv) benefit (v) aseptic [10+5]
- 3.(a) Sketch the character of Edward Middleton.
(b) Write about any one of the educational tours you went on during your school or college days. [10+5]
- 4.(a) Justify the title 'Three Days to See' by Helen Keller.
(b) Develop a dialogue between an employee and the Manager. The employee wants to go on leave for one week and the Manager refuses to grant the leave. The employee should try and convince the manager. [10+5]
- 5.(a) Write about the importance of Gender Equality.
(b) Fill in the blanks with suitable verb forms.
(i) She _____ mangoes (sell).
(ii) The teacher _____ a report last week (receive).
(iii) John _____ a car recently (purchase).
(iv) This building _____ to my brother (belong) .
(v) I _____ go to school tomorrow (be). [10+5]
- 6.(a) 'Coordination between the members of the team is essential for the smooth running of work'. Explain.
(b) Correct and rewrite the following sentences/questions.
(i) Are you having some money?
(ii) She work hard.
(iii) I need an information.
(iv) He and I am writing the exam.
(v) He returned back from London last year. [10+5]



- 7.(a) Expand the line below into a paragraph.
'Wisdom is better than knowledge'
- (b) Rewrite the following sentences as directed.
- (i) He enjoyed very much (add a reflexive pronoun)
 - (ii) He lately realized that he is almost wrong (pick the adverbs)
 - (iii) He has bought a car last year (correct the tense)
 - (iv) Strength (write the verb form)
 - (v) He is a very clever boy (pick the adjective)

[10+5]

- 8.(a) Give one word substitute for the following
- (i) Short narrative conveying a moral _____
 - (ii) Make up for _____
 - (iii) Being unable to divide _____
 - (iv) The stage of development _____
 - (v) Determination to keep trying _____
- (b) Tick the right answer
- (i) He writes _____
(a) legibly (b) legably (c) lengthy (d) timely
 - (ii) Related to money, economy: _____
(a) Poverty (b) pecuniary (c) savings (d) spending
 - (iii) To behave in a superior manner to impress others is _____
(a) patronize (b) hanghtily (c) beat the beech (d) pompous
 - (iv) university : college : : continent : _____
(a) state (b) country (c) nation (d) globe
 - (v) Recluse : Hermit : : friend : _____
(a) hostile (b) Rival (c) exclude (d) gregarious
- (c) What is a gerund? Explain with examples.

[5+5+5]



Subject Code : R10101/R10 (2012-13 Batch)

Set No - 2

I B.Tech I Semester Supplementary Examinations Feb./Mar. - 2014

ENGLISH – I

(Common to All Branches)

Time: 3 hours

Max. Marks : 75

Answer any FIVE Questions
All Questions carry equal marks

* * * * *

- 1.(a) Why did Gandhi want to take the task of becoming an English gentle man and why did he withdraw from pursuing that idea?
(b) Give the synonyms for the following
(i) dreary (ii) tryst (iii) earnest (iv) pecuniary (v) mend [10+5]
- 2.(a) What kind of people according to Barnum can attain pecuniary independence?
(b) Write the antonyms for the following words.
(i) irrational (ii) vanity (iii) unforeseen (iv) sluggish (v) cheerful [10+5]
- 3.(a) Narrate in your own words lawyer Gibb's offer to Middleton.
(b) Write about any of your travel experiences. [10+5]
- 4.(a) List Keller's visits to various places on her second seeing day.
(b) Write a dialogue between a teacher and a parent. The parent wants to know about his son's marks and attendance but the teacher is busy at that moment. [10+5]
- 5.(a) Write about journalism as a career for woman.
(b) Fill in the blanks with suitable verb forms.
(i) The president _____ at 9 a.m tomorrow. (arrive)
(ii) We ___ to move to the new house next week. (go)
(iii) She _ if you say sorry. (work)
(iv) She ___ to market yesterday. (go)
(v) I _____ here since morning. (wait) [10+5]
- 6.(a) Write about importance of 'Adaptability at work place'
(b) Correct and rewrite the following sentences.
(i) Where you are?
(ii) I have broke the glass.
(iii) She described about her project.
(iv) I am suffering with fever.
(v) I and Ram are friends. [10+5]



- 7.(a) Expand the saying into a paragraph. “An idle man’s brain is a devil’s workshop”.
- (b) Rewrite as directed.
- (i) Flexible (change to a noun)
 - (ii) He enjoyed very much (add a reflexive pronoun)
 - (iii) Miserable (use the word in your own sentence)
 - (iv) Adaptability (make an adjective)
 - (v) It rained heavily, severely and damaged the huts. (correct the order of adjectives)
- [10+5]
- 8.(a) Give one word substitutes for the following
- (i) Persons competing with each other.
 - (ii) A long narrative poem.
 - (iii) The crime of creating a false document.
 - (iv) One who hates mankind.
 - (v) Process for cooking a dish.
- (b) Tick the right answer.
- (i) coward : fear : : soldier: _____
(a) war (b) battle (c) courage (d)vanity
 - (ii) melancholy : sadness : : merriment : _____
(a) strength (b) joy (c) moody (d) cranky
 - (iii) Humility : arrogance : : impartial : _____
(a) biased (b) mean (c) jovial (d) ignorance
 - (iv) None of us found the movie _____
(a) black (b) reality (c) interesting (d) blind
 - (v) He is not only kind but also _____
(a) stand (b) illiterate (c) greedy (d) generous
- (c) Write about ‘to infinitive’ and give examples.

[5+5+5]



Subject Code : R10101/R10 (2012-13 Batch)

Set No - 3

I B.Tech I Semester Supplementary Examinations Feb./Mar. - 2014

ENGLISH – I

(Common to All Branches)

Time: 3 hours

Max. Marks : 75

Answer any FIVE Questions
All Questions carry equal marks

* * * * *

- 1.(a) How did Gandhi realize that it was not necessary to imitate others? What changes did he make in his lifestyle as he realized this?
(b) Write the synonyms for the following words
(i) aseptic (ii) redeem (iii) recluse (iv) dormant (v) mend [10+5]
- 2.(a) 'True economy consists in always making the income exceed the out- go' – Elaborate this view of P.T Barnum.
(b) Give the antonyms for the following words
(i) inevitable (ii) unforeseen (iii) modest (iv) voluntary (v) courage [10+5]
- 3.(a) Who do you think is the man, of moral values, lawyer Gibbs or Edward Middleton? Give reasons.
(b) How does travelling to different places help us? [10+5]
- 4.(a) Enumerate Keller's plans for her third and last day of vision.
(b) Write a dialogue between your area post-man and you when you inform him about your change of address. [10+5]
- 5.(a) 'Discrimination against women is a social evil' - Discuss.
(b) Fill in the blanks with suitable verb forms
(i) John ___ violin. (play)
(ii) He _____ (come), if you _____ him. (invite)
(iii) It _____ to rain. (go)
(iv) I ___ him for a long time. (know) [10+5]
- 6.(a) What are life skills? How are they different from communication skills?
(b) Correct the following sentences.
(i) My brother have two houses.
(ii) I and my friend attended the seminar.
(iii) Every one feel responsible.
(iv) They doesn't want to go with him.
(v) We discussed about the matter. [10+5]



- 7.(a) 'It is the mind that makes heaven out of hell and hell out of heaven' - Explain the line in a paragraph.
- (b) Rewrite the following as directed.
- (i) Flexibility (change to Adjective)
 - (ii) Merry (form an adverb)
 - (iii) Conduct (make negative adding a prefix)
 - (iv) Loaf (write the plural form)
 - (v) I hurt..... (add a reflexive pronoun and make a sentence)

[10+5]

- 8.(a) Give one word substitutes for the following.
- (i) A feeling of well being_____
 - (ii) Area of knowledge _____
 - (iii) Long bench with back and sides _____
 - (iv) A mental view or vision _____
 - (v) One who eats too much _____
- (b) Tick the right answer
- (i) He writes _____
(a) legibly (b) legably (c) lengthy (d) timely
 - (ii) Related to freedom, and not depend ____
(a) dependence (b) independence (c) reliability (d) open
 - (iii) A stitch in time_____
(a) is good (b) saves nine (c) correct (d) wrong
 - (iv) university : college : : continent : _____
(a) State (b) country (c) nation (d) globe
 - (v) Recluse : Hermit : : friend : _____
(a) Hostile (b) Rival (c) seclude (d) gregarious
- (c) Write about the 'progressive' form of the verb with examples.

[5+5+5]



Subject Code : R10101/R10 (2012-13 Batch)

Set No - 4

I B.Tech I Semester Supplementary Examinations Feb./Mar. - 2014

ENGLISH – I

(Common to All Branches)

Time: 3 hours

Max. Marks : 75

Answer any FIVE Questions
All Questions carry equal marks

* * * * *

- 1.(a) What are Gandhi's experiences as a student in London?
(b) Give the synonyms for the following words:
(i) utterance (ii) caution (iii) jaunt (iv) gusty (v) emulate [10+5]
- 2.(a) What are Barnum's suggestions for practicing economy?
(b) Write the Antonyms of the following words:
(i) independence (ii) courage (iii) mitigate (iv) mind (v) neglect [10+5]
- 3.(a) Who is the hero in the drama "The Drunkard" Lawyer Gibbs or Edward Middleton?
Give reasons.
(b) Write about any two important places you want to visit in India. [10+5]
- 4.(a) Summarise Hellen Keller's views about the importance of senses, particularly eyes.
(b) Write the conversation between a traffic police and you, while you are driving without proper license. The police charges you heavy fine but you do not have money. [10+5]
- 5.(a) Explain the problems with 'Down' system'.
(b) Fill in the blanks with suitable verb forms.
(i) Birds _____ in the sky. (fly)
(ii) He _____ much better now. (feel)
(iii) If you _____ hard, you _____ pass the exam. (work,pass)
(iv) You _____ the exam by this time tomorrow. (complete) [10+5]
- 6.(a) How does non-verbal communication and attitude help a team leader? Explain.
(b) Correct and rewrite the following sentences.
(i) The pen or pencil are in the bag.
(ii) I and Hari worked on this project.
(iii) He worked hardly, so he passed the exam.
(iv) Each of the sisters are good at singing.
(v) She has seen the movie last week. [10+5]



- 7.(a) Expand the saying into a paragraph 'Too many cooks spoil the broth.'
(b) Rewrite as directed.
(i) Respect (add a prefix to make the opposite)
(ii) Usjbtec (correct the jumbled word)
(iii) Virtual (make an adverb)
(iv) The serene cold weather damaged the cotton fields. (pick the adjectives)
(v) He did it (add a reflexive pronoun)

[10+5]

- 8.(a) Give one word substitutes for the following:

- (i) A mental view or vision _____
(ii) A feeling of sadness _____
(iii) One who helps others _____
(iv) Being only one of its kind _____
(v) A study of races _____

- (b) Tick the right answer.

- (i) coward : fear : : soldier _____
(a) war (b) battle (c) courage (d)vanity
(ii) melancholy : sadness : : merriment : _____
(a) Strength (b) joy (c) moody (d) cranky
(iii) Humility : arrogance : : impartial : _____
(a) Biased (b) mean (c) jovial (d) ignorance
(iv) None of us found the claims _____ to believe.
(a) genuine (b) false (c) vague (d) wrong
(v) He is not only kind but also _____
(a) stand (b) illiterate (c) greedy (d) generous

- (c) Write about simple present tense with examples.

[5+5+5]



ENGLISH – I

(Common to All Branches)

Time: 3 hours

Max. Marks : 75

Answer any FIVE Questions
All Questions carry equal marks

* * * * *

- 1.(a) What is the importance of the quality “Reliability” for a team member? Explain with examples.
(b) Write the Synonyms for the following words:
(i) academic (ii) quest (iii) destiny (iv) heritage (v) vicious [10+5]
- 2.(a) ‘ Problem Solving’ and Decision Making are important qualities of a team leader. Elaborate.
(b) Write the antonyms for the following words.
(i) exclusive (ii) misery (iii) rivals (iv) minor (v) inalienable [10+5]
- 3.(a) What are the important places that you would like to visit in India?
(b) What steps do you suggest to go on a long trip to a distant place? [10+5]
- 4.(a) ‘Write a dialogue between you and your neighbor about the colony committee meeting and the issues to be discussed there.
(b) Invite your friend to attend your convocation ceremony. Write a telephone conversation. [10+5]
- 5.(a) Write an essay on ‘Gender Bias’
(b) Fill the blanks with suitable verb forms.
(i) He ----- a football player. (be)
(ii) Sita ----- the movie last week. (see)
(iii) I ----- TV when the postman ----- the parcel. (watch,bring)
(iv) It ----- since morning. (rain) [10+5]
- 6.(a) Suggest some measures to improve your “learning skills.
(b) Correct and rewrite the following sentences:
(i) Ten miles are a long distance.
(ii) She prefers coffee than tea.
(iii) Either Rose or Lily get the chance to participate in the concert.
(iv) They enjoyed the picnic very much.
(v) He ran fastly. [10+5]
- 7.(a) Expand the saying into a paragraph- ‘As you sow, so shall you reap.’
(b) Rewrite as directed
(i) Manage (Change the verb into adjective)
(ii) Slowly and steadily she rose to a high position (pick the adverbs)
(iii) Emeder(Correct the spelling)
(iv) Leaf(write the plural form)
(v) What your name is?(Correct the word order) [10+5]

- 8.(a) Write one word substitute for the following:
- (i) To meet with _____
 - (ii) Only one of its kind _____
 - (iii) One who is stingy about money _____
 - (iv) A meeting for exchange of information _____
 - (v) To occupy something forcibly _____
- (b) Tick the right answer
- (i) blemish : fault :: flaw :
(a) error (b) recur (c) blame (d) fancy
 - (ii) ignite : extinguish : harvest : _____
(a) plant (b) rest (c) trust (d) remove
 - (iii) Cluster: group :: bunch :
(a) fruits (b) huddle (c) grapes (d) houses
 - (iv) release : arrest :: convict :
(a) set (b) exile (c) acquit (d) hang
 - (v) hasty : patience :: unqualified : _____
(a) skilled (b) logic (c) credentials (d) gullible
- (c) Write about 'to infinitive'. Give three examples.

[5+5+5]

PDFill PDF Editor with Free Writer and Tools



ENGLISH – I

(Common to All Branches)

Time: 3 hours

Max. Marks : 75

Answer any FIVE Questions
All Questions carry equal marks

* * * * *

- 1.(a) Explain the importance of English language communication skills for professionals.
(b) Write the Synonyms for the following words.
(i) release (ii) palpable (iii) remnant (iv) academic (v) exploitative [10+5]
- 2.(a) What are the characteristics of a good team work?
(b) Write the antonyms for the following words.
(i) mend (ii) voluntary (iii) infest (iv) inevitable (v) reject [10+5]
- 3.(a) Describe your trip to a museum or a dam.
(b) Write about the advantages of tourism. [10+5]
- 4.(a) Write a dialogue between two employees about the new products released by their company, their benefits to the consumers, competitors and likely profits to the company.
(b) Develop a dialogue between you and a shop keeper. Ask for the details of the goods available in his shop comparing the prices of various companies. [10+5]
- 5.(a) Write an essay on the 'Evils of Downy System'.
(b) Fill in the blanks with suitable verb forms.
(i) I ----- a letter next week to my teacher. (write)
(ii) He ----- green tea every morning.(drink)
(iii) The boy----- while it ----- raining.(play, rain)
(iv) She ----- for the bus since morning.(wait) [10+5]
- 6.(a) Explain the importance of creativity and problem solving skills for an Engineer.
(b) Correct and rewrite the following sentences.
(i) Ram went to temple every Monday.
(ii) Each of the boys have to pay the fees by next Tuesday.
(iii) I gave him the key just now.
(iv) Where you are?
(v) He lost his purse. Isn't it? [10+5]
- 7.(a) Expand this saying into a paragraph- 'Old is gold'.
(b) Rewrite as directed.
(i) Courage (Change the noun into adjective)
(ii) Regular (Write the adverb form)
(iii) Nuohor (Correct the spelling)
(iv) Medium (write the plural form)
(v) The cool and dry climate is pleasant.(pick the adjectives) [10+5]



- 8.(a) Give one word substitutes for the following.
- (i) A long narrative poem _____
 - (ii) To move around in a circular motion _____
 - (iii) A place where birds are kept _____
 - (iv) An area where wild life is preserved _____
 - (v) A person who can speak many languages _____
- (b) Tick the right answer.
- (i) greed : generous :: miser: _____
(a) clumsy (b) fury (c) mean (d) spendthrift
 - (ii) epic : fable :: classic ::
(a) theme (b) tale (c) book (d) play
 - (iii) locker: storage :: telephone : _____
(a) communication (b) cash (c) bill (d) mobile
 - (iv) elderly : youth :: healthy : _____
(a) famous (b) rational (c) smug (d) illness
 - (v) hidden : visible :: flimsy :
(a) delicious (b) sturdy (c) classy (d) edible
- (c) What is a gerund? Give three examples.

[5+5+5]

PDFill PDF Editor with Free Writer and Tools



ENGLISH – I

(Common to All Branches)

Time: 3 hours

Max. Marks : 75

Answer any FIVE Questions
All Questions carry equal marks

* * * * *

- 1.(a) 'Positive attitude results in Problem Solving and happy living' Analyze.
(b) Give the Synonyms for the following words:
(i) pledge (ii) misery (iii) vicious (iv) puberty (v) commitment [10+5]
- 2.(a) What do you think are the good qualities you need to develop to become a good member of the team?
(b) Write the antonyms for the following words:
(i) rival (ii) rational (iii) manufacture (iv) inevitable (v) serene [10+5]
- 3.(a) Give the details of your recent pleasure trip with your friends or family members.
(b) Suggest the safety measures when someone visits new places. [10+5]
- 4.(a) You have an argument with your neighbor when the latter parked his vehicles in front of your house. He tries to convince you but you are stubborn.
(b) Your manager refused to grant you leave for a pleasure trip with your family. Convince him with the reasons. Write in the form of a dialogue. [10+5]
- 5.(a) 'Angels tread where women is respected' Elaborate.
(b) Fill in the blanks with suitable verb forms.
(i) I ----- the doctor tonight. (meet)
(ii) He ----- better after the treatment. (feel)
(iii) The govt ----- him the Best teacher award last year. (give)
(iv) The train -----, before my friend ----- the station. (leave, reach) [10+5]
- 6.(a) 'Adaptability is an essential quality to achieve team goals.' Explain.
(b) Correct and rewrite the following sentences/questions.
(i) He enjoyed the picnic.
(ii) Did he gone there?
(iii) He is working hardly for his exams.
(iv) It is raining, wasn't it?
(v) Ram and myself are attending the meeting. [10+5]
- 7.(a) Expand the saying into a paragraph- 'Empty vessels make more noise'
(b) Rewrite as directed
(i) Valuable(Change the noun into adjective)
(ii) Secret (Write the adverb form)
(iii) Lnolye(Correct the spelling)
(iv) Alumnus (write the plural form)
(v) You must others respect(Correct the word order) [10+5]



- 8.(a) Give one word substitutes.
- (i) The stage of development _____
 - (ii) A person who starts any movement or change in the system _____
 - (iii) The conventions of a particular social group _____
 - (iv) One who loves man kind _____
 - (v) One who is fond of food _____
- (b) Tick the right answer
- (i) Anger : frustration:: serenity :-----
(a) despair (b) wrath (c) satisfaction (d) misery
 - (ii) elderly : youth :: healthy : _____
(a) famous (b) rational (c) smug (d) illness
 - (iii) suburb : outskirts :: city : _____
(a) rural (b) urban (c) village (d) dense
 - (iv) Seismograph : Earthquake :: thermometer :-----
(a) health (b) abacus (c) stethoscope (d) temperature
 - (v) Shard : Glass :: scrap :-----
(a) morsel (b) quilt (c) wood (d) rope
- (c) Write about progressive verb form and give 3 examples.

[5+5+5]

PDFill PDF Editor with Free Writer and Tools



ENGLISH – I

(Common to All Branches)

Time: 3 hours

Max. Marks : 75

Answer any FIVE Questions
All Questions carry equal marks

* * * * *

- 1.(a) Write about the importance of transparency and good communication for team work.
(b) Write the Synonyms for the following words:
(i) redeem (ii) paranoia (iii) solemn (iv) transmit (v) trust [10+5]
- 2.(a) 'Reliability and commitment make one a successful person' Elucidate.
(b) Write the antonyms for the following words.
(i) vulnerable (ii) summit (iii) rivals (iv) aseptic (v) voluntary [10+5]
- 3.(a) What are the important tourist/religious places that you would like to visit in your life?
Explain their importance.
(b) Suggest some steps to ensure safety of tourists in India. [10+5]
- 4.(a) You have to make arrangements for your sister's wedding. Write a dialogue on the discussion with your father.
(b) Explain to your mother the reason for your coming late in the night. Write a telephonic conversation when your mother is upset with your late coming. [10+5]
- 5.(a) Explain your views on "Women Empowerment".
(b) Fill in the blanks with suitable verb forms.
(i) She----- tea. (like)
(ii) Either of the sisters ----- good at singing. (be)
(iii) I ----- the conference (attend), if they ----- me.(invite)
(iv) She is----- noise. (hear) [10+5]
- 6.(a) Write an essay on Adaptability and problem solving skills.
(b) Correct and rewrite the following sentences.
(i) Birds flies in the air.
(ii) He has gone to market last Sunday.
(iii) Every boy and girl have a bag.
(iv) The price of vegetables are high these days.
(v) I enjoyed the dinner. [10+5]
- 7.(a) Expand the saying into a paragraph- 'To err is human; To forgive is divine'
(b) Rewrite as directed
(i) Loyalty(Change the noun into adjective)
(ii) Wild (Write the adverb form)
(iii) Jetcer (Correct the spelling)
(iv) Child(write the plural form)
(v) It rained last heavily night (Correct the word order) [10+5]



- 8.(a) Give one word substitutes.
- (i) One who collects stamps _____
 - (ii) Study of birds _____
 - (iii) An area where wild life is preserved _____
 - (iv) A binding promise or agreement _____
 - (v) Love for mankind _____
- (b) Tick the right answer.
- (i) Novel : Book :: epic : -----
(a) poem (b) fable (c) tale (d) play
 - (ii) Beauty : admire :: food :
(a) depressed (b) fury (c) relish (d) foolish.
 - (iii) Realistic : Quixotic :: tormentor : -----
(a) lethargic (b) scholar (c) sympathetic (d) pedantic
 - (iv) hidden : visible :: flimsy :
(a) delicious (b) sturdy (c) classy (d) edible
 - (v) Hard : easy :: rigid :
(a) flexible (b) rough (c) solid (d) rocky
- (c) Write about simple present tense with examples.

[5+5+5]

PDFill PDF Editor with Free Writer and Tools



MATHEMATICS-I

(Common to All Branches)

Time: 3 hours

Max. Marks: 70

Question Paper Consists of **Part-A** and **Part-B**
 Answering the question in **Part-A** is Compulsory,
 Three Questions should be answered from **Part-B**

PART-A

- 1.(i) Find the orthogonal trajectories of the curve $r = a(1 + \cos \theta)$.
 (ii) If $x = r \sin \theta \cos \phi$, $y = r \sin \theta \sin \phi$, $z = r \cos \theta$, find $\frac{\partial(r, \theta, \phi)}{\partial(x, y, z)}$, given that $\frac{\partial(x, y, z)}{\partial(r, \theta, \phi)} = r^2 \sin \theta$.
 (iii) Find the Laplace transform of $f(t) = \begin{cases} t, & 0 < t < 1 \\ 0, & t > 1 \end{cases}$ using Heaviside function.
 (iv) Let the heat conduction in a thin metallic bar of length L is governed by the equation $\frac{\partial u}{\partial t} = a^2 \frac{\partial^2 u}{\partial x^2}$, $t > 0$. If both ends of the bar are held at constant temperature zero and the bar is initially has temperature $f(x)$, find the temperature $u(x, t)$.
 (v) Solve $p^2 + pq = z^2$.
 (vi) Find $\frac{1}{D^2 - 4D + 4} x^2 \sin x$. [4+4+4+4+3+3]

PART-B

- 2.(a) Solve $y(2x^2 - xy + 1)dx + (x - y)dy = 0$
 (b) Find the complete solution of $y'' + 2y = x^2 e^{3x} + e^x \cos 2x$ [8+8]
- 3.(a) Solve $\frac{dy}{dx} + x \sin 2y = x^3 \cos^2 y$
 (b) Find the solution of $\frac{d^2 y}{dx^2} + 4y = \sin 3x + \cos 2x$. [8+8]
- 4.(a) Find the Laplace transform of $f(t) = \frac{\cos at - \cos bt}{t}$.
 (b) If $x = \sqrt{vw}$, $y = \sqrt{uw}$, $z = \sqrt{uv}$ and $u = r \sin \theta \cos \phi$, $v = r \sin \theta \sin \phi$ and $w = r \cos \theta$, find $\frac{\partial(x, y, z)}{\partial(r, \theta, \phi)}$. [8+8]
- 5.(a) Expand $f(x, y) = e^y \ln(1 + x)$ in powers of x and y using MacLaurin's Series
 (b) Solve $y'' - 8y' + 15y = 9te^{2t}$, $y(0) = 5$ and $y'(0) = 10$ using Laplace transforms [8+8]
- 6.(a) Solve $(y + xz)p - (x + yz)q = x^2 - y^2$.
 (b) Solve the partial differential equation $px + qy = 1$. [8+8]
- 7.(a) Find the partial differential equation of all spheres whose centers lie on z- axis.
 (b) Find the solution of the wave equation $\frac{\partial^2 u}{\partial t^2} = a^2 \frac{\partial^2 u}{\partial x^2}$, if the initial deflection is $f(x) = \begin{cases} \frac{2k}{l}x & \text{if } 0 < x < l/2 \\ \frac{2k}{l}(l-x) & \text{if } \frac{l}{2} < x < l \end{cases}$ and initial velocity equal to 0. [8+8]

MATHEMATICS-I

(Common to All Branches)

Time: 3 hours**Max. Marks: 70**

Question Paper Consists of **Part-A** and **Part-B**
 Answering the question in **Part-A** is Compulsory,
 Three Questions should be answered from **Part-B**

PART-A

- 1.(i) Find the complete solution of $(D^4 + 16)y = 0$.
- (ii) If $x = r\cos\theta, y = r\sin\theta, z = z$, find $\frac{\partial(r,\theta,z)}{\partial(x,y,z)}$, given that $\frac{\partial(x,y,z)}{\partial(r,\theta,z)} = r$.
- (iii) Solve $x^2p^2 + y^2q^2 = z^2$.
- (iv) Find the solution, by Laplace transform method, of the integro-differential equation

$$y' + 3y + 2 \int_0^t y(t)dt = t$$
- (v) Find the differential equation of the orthogonal trajectories for the family of parabola through the origin and foci on y-axis.
- (vi) Find the solution of wave equation in one dimension using the method of separation of variables.

[3+3+4+4+4+4]

PART-B

- 2.(a) Solve $y(y^2 - 2x^2)dx + x(2y^2 - x^2)dy = 0$
- (b) Find the complete solution of $y'' + 5y' - 6y = \sin 4x \sin x$. [8+8]
- 3.(a) Solve $\cos x dy = y(\sin x - y)dx$.
- (b) Find the solution of $\frac{d^2y}{dx^2} - 4\frac{dy}{dx} + 3y = 2xe^{3x} + 3e^x \cos 2x$. [8+8]
- 4.(a) Find the Laplace transform of $f(t) = \int_0^t e^{-u} \cos u du$.
- (b) Find the shortest distance from origin to the surface $xyz^2 = 2$. [8+8]
- 5.(a) Find $\frac{\partial(u,v)}{\partial(r,\theta)}$ if $u = 2axy$ and $v = a(x^2 - y^2)$, where $x = r\cos\theta$ and $y = r\sin\theta$.
- (b) Solve $y'' - 8y' + 15y = 9te^{2t}$, $y(0) = 5$ and $y'(0) = 10$ using Laplace transforms [8+8]
- 6.(a) Form the partial differential equation by eliminating the arbitrary function from $xyz = f(x + y + z)$.
- (b) Find the solution of $(D^2 - DD' - 2D'^2)z = (y - 1)e^x$, where $D = \frac{\partial}{\partial x}$ and $D' = \frac{\partial}{\partial y}$. [8+8]
- 7.(a) Solve the partial differential equation $xzp + yzq = xy$.
- (b) Find the temperature in a bar of length l which is perfectly insulated laterally and whose ends O and A are kept at 0°C , given that the initial temperature at any point P of the rod is given by f(x). [8+8]



MATHEMATICS-I

(Common to All Branches)

Time: 3 hours**Max. Marks: 70**

Question Paper Consists of **Part-A** and **Part-B**
 Answering the question in **Part-A** is Compulsory,
 Three Questions should be answered from **Part-B**

PART-A

- 1.(i) Find the dimensions of rectangular box of maximum capacity whose surface area is S.
- (ii) Find the orthogonal trajectories of the family of curves $x^{2/3} + y^{2/3} = a^{2/3}$.
- (iii) A generator having emf 100 volts is connected in series with a 10 ohm resistor and an inductor of 2 henries. If the switch is closed at a time $t=0$, find the current at time $t>0$.
- (iv) Find the Laplace transform of $f(t) = \begin{cases} t, & 0 < t < 1 \\ 0, & t > 1 \end{cases}$ using Heaviside function.
- (v) Solve $pq+qx = y$.
- (vi) Find the solution of $2x \frac{\partial z}{\partial x} - 3y \frac{\partial z}{\partial y} = 0$ by the method of separation of variables.

[4+4+4+4+3+3]

PART-B

- 2.(a) Solve $y(1+xy)dx + x(1-xy)dy = 0$
- (b) Find the complete solution of $y'' + 4y = e^x \sin^2 x$. [8+8]
- 3.(a) Solve $2xy' + y = \frac{2x^2}{y^3}, y(1) = 2$
- (b) Find the solution of $\frac{d^2y}{dx^2} - 4\frac{dy}{dx} + 5y = e^{2x} + 3 \cos(4x + 3)$. [8+8]
- 4.(a) Find the Laplace transform of $f(t) = te^{-2t} \cos t$.
- (b) Find the maxima and minima of $x^3 + 3xy^2 - 15x^2 - 15y^2 + 72x$. [8+8]
- 5.(a) Expand $f(x, y) = e^{xy}$ in powers of $(x-1)$ and $(y-1)$.
- (b) Solve $y'' + 7y' + 10y = 4e^{-3t}, y(0) = 0$ and $y'(0) = -1$ using Laplace transforms. [8+8]
- 6.(a) Form the partial differential equation by eliminating the arbitrary constants 'a' and 'b' from $2z = \frac{x^2}{a^2} + \frac{y^2}{b^2}$.
- (b) Find the solution of $(4D^2 + 12DD' + 9D'^2)z = e^{3x-2y}$, where $D = \frac{\partial}{\partial x}$ and $D' = \frac{\partial}{\partial y}$. [8+8]
- 7.(a) Solve the partial differential equation $p \tan x + q \tan y = \tan z$.
- (b) A tightly stretched string with fixed end points $x=0$ and $x=l$ is initially in a position given by $y = y_0 \sin^3 \frac{\pi x}{l}$. If it is released from rest from this position, find the displacement $y(x, t)$. [8+8]



MATHEMATICS-I

(Common to All Branches)

Time: 3 hours**Max. Marks: 70**

Question Paper Consists of **Part-A** and **Part-B**
 Answering the question in **Part-A** is Compulsory,
 Three Questions should be answered from **Part-B**

PART-A

- 1.(i) Find the distance from the centre at which the velocity in simple harmonic motion will be 1/3rd of the maximum.
- (ii) Find a point within a triangle such that the sum of the squares of its distances from the three vertices is minimum.
- (iii) Find the solution, by Laplace transform method of the integro-differential equation $y' + 4y = \int_0^t y(t)dt$, $y(0) = 0$.
- (iv) Uranium disintegrates at a rate proportional to the amount present at that time. If M and N grams of Uranium are present at times T_1 and T_2 respectively, find the half life of Uranium.
- (v) Find the complete solution of $(D^3 - 3D^2D' + 3DD'^2 - D'^3)z = 0$.
- (vi) Solve $z^2 = 1 + p^2 + q^2$.

[4+4+4+4+3+3]

PART-B

- 2.(a) Solve $(3y^2 + 4xy - x)dx + x(x + 2y)dy = 0$
- (b) Find the solution of $\frac{d^2y}{dx^2} + 5\frac{dy}{dx} - 6y = \sin 4x \cos x$. [8+8]
- 3.(a) Find the complete solution of $y'' + 2y = x^2 e^{3x} + e^x \cos 2x$.
- (b) Solve $xz' + z \log z = z(\log z)^2$. [8+8]
- 4.(a) Find the Laplace transform of $f(t) = te^{2t} \cos 2t$.
- (b) If $u = \sin^{-1}\left(\frac{x^3+y^3}{\sqrt{x}+\sqrt{y}}\right)$, prove that $xu_x + yu_y = \frac{5}{2} \tan u$. [8+8]
- 5.(a) If $w = (y - z)(z - x)(x - y)$, find the value of $\frac{\partial w}{\partial x} + \frac{\partial w}{\partial y} + \frac{\partial w}{\partial z}$.
- (b) Solve $y'' + 2y' + 5y = e^{-t} \sin t$, $y(0) = 0$ and $y'(0) = 1$ using Laplace transforms. [8+8]
- 6.(a) Form the partial differential equation by eliminating the arbitrary constants 'a' and 'b' from $z = ax + by + a^2 + b^2$.
- (b) Using method of separation of variables, solve $u_{xt} = e^{-t} \cos x$ with $u(x, 0) = u(0, t) = 0$. [8+8]
- 7.(a) Find the temperature in a thin metal rod of length L, with both ends insulated and with initial temperature in the rod is $\sin\left(\frac{\pi x}{L}\right)$.
- (b) Solve the partial differential equation $px^2 + qy^2 = z^2$. [8+8]

I B.Tech I Semester Supplementary Examinations, Feb/Mar 2014
MATHEMATICS-I

(Common to Civil Engineering, Electrical & Electronics Engineering,
Mechanical Engineering, Electronics & Communication Engineering,
Computer Science & Engineering, Chemical Engineering, Electronics &
Instrumentation Engineering, Bio-Medical Engineering, Information
Technology, Electronics & Computer Engineering, Aeronautical
Engineering, Bio-Technology, Automobile Engineering, Mining and
Petroleum Technology)

Time: 3 hours

Max Marks: 75

Answer any FIVE Questions
All Questions carry equal marks

1. (a) Solve $(x^2 + y^2 - a^2)x dx + (x^2 - y^2 - b^2)y dy = 0$. [7+8]
(b) If air is maintained at $20^\circ C$ and the temperature of the body cools from $80^\circ C$ to $60^\circ C$ in 10 minutes, find the temperature of the body after 30 minutes.
2. (a) Solve $(D^2 + a^2)y = \sec ax$
(b) Solve $(D^2 + 4)y = e^x + \sin 2x$ [8+7]
3. (a) If $V = \log(x^2 + y^2) + x - 2y$ find $\frac{\partial V}{\partial x}, \frac{\partial V}{\partial y}, \frac{\partial^2 V}{\partial x^2}, \frac{\partial^2 V}{\partial y^2}$.
(b) If $U = xe^{xy}$ where $x^2 + y^2 + 2xy = 1$, find $\frac{\partial^2 U}{\partial x^2}$. [8+7]
4. (a) Trace the curve $r = 2 + 3 \sin \theta$.
(b) Trace the curve $y^2(2a - x) = x^3$. [8+7]
5. (a) Find the surface of the solid generated by revolution of the lemniscate $r^2 = a^2 \cos^2 \theta$ about the initial line.
(b) Show that the whole length of the curve $x^2(a^2 - x^2) = 8a^2y^2$ is $\pi a\sqrt{2}$. [8+7]
6. (a) Show that $\int_0^{4a} \int_{\frac{y^2}{4a}}^y \frac{x^2 - y^2}{x^2 + y^2} dx dy = 8a^2 \left(\frac{\pi}{2} - \frac{5}{3} \right)$.
(b) Evaluate $\iint_R y dx dy$ where R is the domain bounded by y-axis, the curve $y = x^2$ and the line $x + y = 2$ in the first quadrant. [8+7]
7. (a) If $V = e^{xyz}(i + j + k)$, find curl V.
(b) Find the constants a and b so that the surface $ax^2 - byz = (a+2)x$ will be orthogonal to the surface $4x^2y + z^3 = 4$ at the point (1, -1, 2) [8+7]
8. (a) Show that the area of the ellipse $x^2/a^2 + y^2/b^2 = 1$ is πab
(b) If $f = (2x^2 - 3z)i - 2xyj - 4xzk$, evaluate
(i) $\int_v \nabla \cdot f dV$ and
(ii) $\int_v \nabla \times f dV$ where V is the closed region bounded by $x = 0, y = 0, z = 0, 2x + 2y + z = 4$. [8+7]

I B.Tech I Semester Supplementary Examinations, Feb/Mar 2014
MATHEMATICS-I

(Common to Civil Engineering, Electrical & Electronics Engineering,
Mechanical Engineering, Electronics & Communication Engineering,
Computer Science & Engineering, Chemical Engineering, Electronics &
Instrumentation Engineering, Bio-Medical Engineering, Information
Technology, Electronics & Computer Engineering, Aeronautical
Engineering, Bio-Technology, Automobile Engineering, Mining and
Petroleum Technology)

Time: 3 hours

Max Marks: 75

Answer any FIVE Questions
All Questions carry equal marks

1. (a) Solve $e^y \left(1 + \frac{dy}{dx}\right) = e^x$
(b) Show that the family of curves $\frac{x^2}{a^2+\lambda} + \frac{y^2}{a^2+\lambda} = 1$, where ' λ ' is a parameter is self orthogonal. [8+7]
2. (a) Solve $(D^2 + 9)y = 2 \cos^2 x$. (b) Solve $\frac{d^2y}{dx^2} + 4y = 2e^x \sin^2 x$. [8+7]
3. (a) Calculate the approximate value of $\sqrt{10}$ to four decimal places using Taylor's theorem.
(b) Find 3 positive numbers whose sum is 600 and whose product is maximum. [8+7]
4. (a) Trace the curve $y = x^2(x^2 - 4)$. (b) Trace the curve $r = \cos \theta$. [8+7]
5. (a) The figure bounded by a parabola and the tangents at the extremities of its latusrectum revolves about the axis of the parabola, Find the volume of the solid thus generated. [8+7]
(b) The segment of the parabola $y^2 = 4ax$ which is cutoff by the latus rectum revolves about the directrix. Find the volume of rotation of the annular region.
6. (a) Evaluate $\int \int (x+y)^2 dx dy$ over the area bounded by the ellipse $\frac{x^2}{a^2} + \frac{y^2}{b^2} = 1$.
(b) Transform the following to Cartesian form and hence evaluate $\int_0^\pi \int_0^a r^3 \sin \theta dr d\theta$. [8+7]
7. (a) Prove that $\nabla r = \bar{r}/r$
(b) Find the angle between the surfaces $x^2 + y^2 + z^2 = 9$ and $z = x^2 + y^2 - 3$ at the point (2,-1,2). [8+7]
8. (a) Evaluate $\iint_S (yzi + z xj + xyk) \cdot dS$ where S is the surface of the sphere $x^2 + y^2 + z^2 = a^2$ in the first octant.
(b) Evaluate $\oint_C (x^2 - 2xy)dx + (x^2y + 3)dy$ around the boundary of the region defined by $y^2 = 8x$ and $x = 2$. [8+7]

I B.Tech I Semester Supplementary Examinations, Feb/Mar 2014
MATHEMATICS-I

(Common to Civil Engineering, Electrical & Electronics Engineering,
Mechanical Engineering, Electronics & Communication Engineering,
Computer Science & Engineering, Chemical Engineering, Electronics &
Instrumentation Engineering, Bio-Medical Engineering, Information
Technology, Electronics & Computer Engineering, Aeronautical
Engineering, Bio-Technology, Automobile Engineering, Mining and
Petroleum Technology)

Time: 3 hours

Max Marks: 75

Answer any FIVE Questions
All Questions carry equal marks

1. (a) Solve $y(\sin x - y) dx = \cos x dy$
(b) If the temperature of air is maintained at $20^{\circ}C$ and the temperature of the body cools from $100^{\circ}C$ to $80^{\circ}C$ in 10 minutes, find the temperature of the body after 20 minutes. [8+7]
2. (a) Solve $(D^2 - 4D + 13)y = e^{2x}$
(b) Solve $(D^2 - 3D + 2)y = \cos h x$ [8+7]
3. (a) If $r + s + t = x$, $s + t = xy$, $t = xyz$, find $\frac{\partial(r,s,t)}{\partial(x,y,z)}$.
(b) Find the extreme points of $f(x, y) = xy + \frac{8}{x} + \frac{8}{y}$. [8+7]
4. (a) Trace the curve $y = \cosh\left(\frac{x}{5}\right)$.
(b) Trace the curve $y^2 = (4-x)(3-x^2)$. [8+7]
5. (a) Find the length of the arc of the curve $y = \log(\sec x)$ from $x = 0$ to $\frac{\pi}{3}$.
(b) Find the perimeter of the loop of the curve $3ay^2 = x(x-a)^2$. [8+7]
6. (a) Evaluate $\int \int r dr d\theta$ over the region bounded by the cardioid $r = a(1 + \cos\theta)$ and outside the circle $r = a$.
(b) Change the order of Integration & evaluate $\int_0^{4a} \int_{\frac{x^2}{4a}}^{2\sqrt{ax}} dy dx$ [8+7]
7. (a) Prove that $(F \times \nabla) \times \bar{r} = -2F$
(b) Determine the constant a so that the vector $V = (x+3y)i + (y-z)j + (x+az)k$ is solenoidal. [8+7]
8. Apply Stokes theorem, to evaluate $\oint_C y dx + z dy + x dz$ where C is the curve of intersection of the sphere $x^2 + y^2 + z^2 = a^2$ and $x + z = a$. [15]



I B.Tech I Semester Supplementary Examinations, Feb/Mar 2014
MATHEMATICS-I

(Common to Civil Engineering, Electrical & Electronics Engineering,
Mechanical Engineering, Electronics & Communication Engineering,
Computer Science & Engineering, Chemical Engineering, Electronics &
Instrumentation Engineering, Bio-Medical Engineering, Information
Technology, Electronics & Computer Engineering, Aeronautical
Engineering, Bio-Technology, Automobile Engineering, Mining and
Petroleum Technology)

Time: 3 hours

Max Marks: 75

Answer any FIVE Questions
All Questions carry equal marks

- Solve $(x+1)\frac{dy}{dx} - y = e^{3x}(x+1)^2$
 - Find the orthogonal trajectory of the family of curves $x^{2/3} + y^{2/3} = a^{2/3}$, where 'a' is a parameter [8+7]
- Solve $(D^3 - 6D^2 + 11D - 6)y = e^{-2x} - e^{-3x}$
 - Solve $\frac{d^2y}{dx^2} - 8\frac{dy}{dx} + 15y = 0$ [8+7]
- If $a = \frac{yz}{x}$, $b = \frac{xz}{y}$, $c = \frac{xy}{z}$, find $\frac{\partial(x,y,z)}{\partial(a,b,c)}$.
 - Find the minimum value of $x^2 + y^2 + z^2$, give that $xyz = a^3$ [8+7]
- Trace the curve $r = \cos 4\theta$.
 - Trace the curve $y^2(1-x) = x^2(1+x)$. [8+7]
- Prove that the volume of the solid generated by the revolution about the x -axis of the loop of the curve $x = t^2$, $y = t - \frac{1}{3}t^3$ is $\frac{3\pi}{4}$. [8+7]
- By changing the order of integration evaluate $\int_0^1 \int_0^{\sqrt{2-x^2}} \frac{x}{x^2+y^2} dy dx$.
 - Evaluate $\int_0^a \int_{a-x}^{\sqrt{a^2-x^2}} y dx dy$ by using change of order of integration. [8+7]
- If $V = e^{xyz}(i+j+k)$, find curl V .
 - Find the constants a and b so that the surface $ax^2 - byz = (a+2)x$ will be orthogonal to the surface $4x^2y + z^3 = 4$ at the point $(1, -1, 2)$ [8+7]
- Use divergence theorem to evaluate $\iint_S (x^3i + y^3j + z^3k) \cdot N ds$, and S is the surface of the sphere $x^2 + y^2 + z^2 = r^2$.
 - Using Green's theorem, Find the area bounded by the hypocycloid $x^{2/3} + y^{2/3} = a^{2/3}$, $a > 0$. Given that the parametric equations are $x = a \cos^3\theta$, $y = a \sin^3\theta$. [8+7]



I B. Tech I Semester Regular Examinations Feb./Mar. - 2014

COMPUTER PROGRAMMING

(Common to CE, ME, CSE, PCE, IT, Chem E, Aero E, AME, Min E, PE, Metal E)

Time: 3 hours

Max. Marks: 70

Question Paper Consists of **Part-A** and **Part-B**
Answering the question in **Part-A** is Compulsory,
Three Questions should be answered from **Part-B**

PART-A

- 1.(i) What is recursive function? What is drawback of using recursion?
- (ii) Write program to show the usefulness of getch() and getche().
- (iii) How are scope rules associated with variables?
- (iv) What is pointer to constant and constant pointer? Are they both same or different.
- (v) Define an array of structure for reading and printing a character, integer and float value.
- (vi) Write a program to read a text file and count the number of characters in the text file.

[4+4+3+4+3+4]

PART- B

- 2.(a) What is structured programming? What are the advantages and disadvantages of structured programming?
- (b) Write a C program that illustrates the local static variables and functions. [8+8]
- 3.(a) What is the purpose of the *do while* and *while* loops? Discuss about their usage. Distinguish between them.
- (b) What is an array of pointers and pointers to an array? Summarize the difference between both of them. [8+8]
- 4.(a) What is an enumerated data type? How is initialization of members to **enum** data type done?
- (b) Describe different file opening modes used with the fopen() function. [8+8]
- 5.(a) Explain briefly the features of an algorithm, flowchart and discuss about Program development steps?
- (b) Explain nested, if else and else if ladder with syntax and give examples respectively? [8+8]
- 6.(a) Describe categories of functions based on arguments and return type and what are different parameter passing methods in functions ?
- (b) Give the implementation of multidimensional arrays using pointers. Let the user specify the number of rows and columns for the array for allocating memory dynamically. [8+8]
- 7.(a) Write a C program that defines a structure student with members name, average, address and displays the category of student according to the following criteria
average >= 70 ----- Distinction
60 <= average < 70 ----- First Class
50 <= average < 60 ----- Second Class
40 <= average < 50 ----- Third Class
average < 40 ----- Fail
- (b) What is a file and what are different type of files and explain? [8+8]



I B. Tech I Semester Regular Examinations Feb./Mar. - 2014

COMPUTER PROGRAMMING

(Common to CE, ME, CSE, PCE, IT, Chem E, Aero E, AME, Min E, PE, Metal E)

Time: 3 hours

Max. Marks: 70

Question Paper Consists of **Part-A** and **Part-B**
Answering the question in **Part-A** is Compulsory,
Three Questions should be answered from **Part-B**

PART-A

- 1.(i) What is the difference between %f, %g and %e format specifiers when used to display a real value defined as *float x=12.34*?
- (ii) Initialize an array of integers. Write a program for printing numbers that are greater than the average of the numbers present in the array.
- (iii) Can main() function be called recursively? If so quote an example.
- (iv) What is the difference between *p++ and p++?
- (v) Define a structure to store the following information of a student- Roll Number, Name, Grade.
Demonstrate the named initialization of the structure by writing a program which prints the name and grade of a student given the roll number as input.
- (vi) Write a program to compare two files and print out the lines where they differ.

[3+4+3+4+4+4]

PART-B

- 2.(a) Describe how the rule of type promotion is followed in a typical expression containing mixed types.
- (b) Illustrate the declaration, initialization of a pointer to a function and calling a function using a function pointer. [8+8]
- 3.(a) What is the usage of fgetc(), fputc() and gets(), puts() functions.
- (b) How is structure passed to a function? Explain. [8+8]
- 4. Explain the following terms
 - (a) User defined functions
 - (b) Predefined functions
 - (c) Header Files
 - (d) C pre-processor[4+4+4+4]
- 5.(a) What is a self referential structure and explain with an example ?What is the advantage of using a self referential structure ?
- (b) Explain various operators in C Programming? [8+8]
- 6. Write a C program that performs binary search on sorted array of elements and trace the program with an example? [16]
- 7.(a) What is a pointer,pointer to a pointer and explain the advantages of using pointers ?
- (b) Explain fseek(), ftell(), rewind(), fclose() file functions. [8+8]

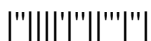

COMPUTER PROGRAMMING

(Common to CE, ME, CSE, PCE, IT, Chem E, Aero E, AME, Min E, PE, Metal E)

Time: 3 hours**Max. Marks: 70**

Question Paper Consists of **Part-A** and **Part-B**
 Answering the question in **Part-A** is Compulsory,
 Three Questions should be answered from **Part-B**

PART-A

- 1.(i) How can the following code be rewritten using conditional operator in C?

```
int m=1, n=2, min;
if (m<n) min=m;
else min=n;
```
- (ii) Can arrays be passed to functions? Justify your answer.
- (iii) A number divisible by any number in the range of 2 and $\frac{n}{2}$ then it is considered to be a factor of the number. If the number is prime then the factor is a prime factor. Write a program to print prime factors of a given number.
- (iv) Define an integer pointer array of 10 numbers. Initialize them to any integer values from the key board. Find the sum and average of these 10 integers.
- (v) Write a program using enumerated types which when given today's date will print out tomorrow's date in the form 31st January.
- (vi) Write a program to read a line at a time from a file. Use fgets() function.

[4+3+4+4+4+3]

PART- B

- 2.(a) Draw the flowchart for calculating the area of an equilateral triangle. Area of equilateral triangle is computed by formula $A = \frac{\sqrt{3}}{4} a^2$, where 'a' is the length of the sides of the triangle.
- (b) Demonstrate the usage of printf() and puts() library functions with the help of a C program. [8+8]
- 3.(a) Give the recursive and iterative functions to find the factorial of a number.
- (b) How is dynamic memory allocation done in C? What library functions are provided by C for dynamic memory allocation? [8+8]
- 4.(a) What is an enumerated data type? How is the initialization of members to **enum** data type done?
- (b) Explain about bit-fields in 'C' [8+8]
- 5.(a) A Fibonacci sequence is defined as follows:
 1, 1, 2, 3, 5, 8,
 Write a program for computing the Fibonacci number sequence using recursion
- (b) Write a C program that performs all arithmetic operations based on user choice using switch case? [8+8]
- 6.(a) What are iterative statements and explain the difference between while and do while loops?
- (b) Write a C program that swaps two numbers using pointers? [8+8]
7. Describe the following (a) putc() (b) getc() (c) putw() (d) getw() [4+4+4+4]

I B. Tech I Semester Regular Examinations Feb./Mar. - 2014

COMPUTER PROGRAMMING

(Common to CE, ME, CSE, PCE, IT, Chem E, Aero E, AME, Min E, PE, Metal E)

Time: 3 hours**Max. Marks: 70**

Question Paper Consists of **Part-A** and **Part-B**
 Answering the question in **Part-A** is Compulsory,
 Three Questions should be answered from **Part-B**

PART-A

- 1.(i) Write an algorithm for computing the sum of the series $1 + x + \frac{x^2}{2!} + \frac{x^3}{3!} + \frac{x^4}{4!} + \dots$ upto N terms.
- (ii) Why do array subscripts start at 0 instead of 1?
- (iii) Compare recursion with iteration.
- (iv) What is wrong with the following code segment?
- ```
int *p;
*p=10;
```
- (v) Write a program using structures and functions to compare two dates.
- (vi) What happens if anyone doesn't close a file?

[4+3+4+4+4+3]

**PART-B**

- 2.(a) What are the advantages and limitations of using flow charts?
- (b) What is a multidimensional array? How is it initialized? How are the elements of multidimensional arrays stored? Comment on the accessing of the elements.
- [6+10]
- 3.(a) Describe the Towers of Hanoi problem. Write a function to solve the Towers of Hanoi problem with 3 disks.
- (b) Write a program that calculates sum of array elements where array elements can be accessed using a pointer to an array?
- [8+8]
- 4.(a) How is a structure variable different from an array with respect to its use as a function parameter?
- (b) Write a C program that calculates GCD of two numbers using a recursive function?
- [8+8]
- 5.(a) Write an algorithm and C program to calculate roots of a quadratic equation and explain how to compile and the run above program?
- (b) Write a C program that calculates the product of two matrices and displays it?
- [8+8]
- 6.(a) Explain character pointer and pointer to a function with examples?
- (b) Write a C program that reads n numbers and writes even numbers into one file EVEN.txt and odd number into another file ODD.txt?
- [8+8]
- 7.(a) Write a C program that copies the content of one file into another file?
- (b) Write a C program that defines a structure-student with members-name, average, address where address is inner structure that contains dno, street, city as members, read the student details and display the output -student name and his city as follows:

| Student name | city |
|--------------|------|
| X            | zzz  |
| Y            | www  |

[8+8]

Subject Code: R13108/R13

Set No - 1

I B. Tech I Semester Regular Examinations Feb./Mar. - 2014

**PROFESSIONAL ETHICS & HUMAN VALUES**

(Common to ECE, EEE, EIE, Bio-Tech, EComE, Agri.E)

Time: 3 hours

Max. Marks: 70

Question Paper Consists of **Part-A** and **Part-B**  
Answering the question in **Part-A** is Compulsory,  
Three Questions should be answered from **Part-B**

\*\*\*\*\*

**PART-A**

- 1.(i) Write short note on the concept of safety.
- (ii) Write about human values.
- (iii) Give an account of History of Ethics.
- (iv) Explain the meaning of moral leadership.
- (v) What are the limitations of code of ethics?
- (vi) What is meant by loyalty and collegiality?
- (vii) What are the social responsibilities of engineers?

[3+3+3+3+3+3+4]

**PART-B**

2. What is the concept of Safety? Explain the Types of Risks. [16]
3. Write about classification of Human Values [16]
4. What do you understand by 'Environmental Ethics'? [16]
5. Write a short note on [8+8]  
(a) Professional Ethics  
(b) Types of Inquiry.
6. 'Engineering as social experimentation- comparison with standard experiments'-  
Elaborate. [16]
- 7.(a) What are the techniques for achieving 'Collegiality'?  
(b) Discuss the importance of Professional Ethics. [8+8]





Subject Code: R13108/R13

Set No - 2

I B. Tech I Semester Regular Examinations Feb./Mar. - 2014

**PROFESSIONAL ETHICS & HUMAN VALUES**

(Common to ECE, EEE, EIE, Bio-Tech, EComE, Agri.E)

Time: 3 hours

Max. Marks: 70

Question Paper Consists of **Part-A** and **Part-B**  
Answering the question in **Part-A** is Compulsory,  
Three Questions should be answered from **Part-B**

\*\*\*\*\*

**PART-A**

- 1.(i) Does globalization solve the global issues?
- (ii) Explain the essence of Indian spirituality.
- (iii) What are the uses of ethical theories?
- (iv) Write short note on 'Industrial Standards'.
- (v) What is meant by voluntary risks?
- (vi) List the moral rights of a salaried Engineer.
- (vii) 'Morals, Values and Ethics are the guiding principles that prescribe the standards of human behaviour' Explain briefly.

[3+3+3+3+3+3+4]

**PART-B**

2. Suggest the steps to ensure the safety of the Engineer as well as the safety of the design of the equipment? [16]
3. Define – [8+8]
  - (a) Privileged information
  - (b) Proprietary information
4. Write about [8+8]
  - (a) Kohlberg's theory
  - (b) Use of ethical theories
5. Explain Intellectual Property Rights. [16]
6. Explain the terms: Integrity, Work ethic, Civic virtue, Character. [16]
7. What are the functions and limitations of 'code of ethics'? [16]



Subject Code: R13108/R13

Set No - 3

I B. Tech I Semester Regular Examinations Feb./Mar. - 2014

**PROFESSIONAL ETHICS & HUMAN VALUES**

(Common to ECE, EEE, EIE, Bio-Tech, EComE, Agri.E)

Time: 3 hours

Max. Marks: 70

Question Paper Consists of **Part-A** and **Part-B**  
Answering the question in **Part-A** is Compulsory,  
Three Questions should be answered from **Part-B**

\*\*\*\*\*

**PART-A**

- 1.(i) Write short note on the concept of safety.
- (ii) Why should we learn and follow ethics?
- (iii) Do you consider courage as virtue? Give your reasons.
- (iv) What is meant by globalization?
- (v) Define the word 'confidentiality'.
- (vi) Write a brief note on 'Consulting Engineering'.
- (vii) How does character form?

[3+3+3+3+3+3+4]

**PART-B**

2. Write an essay on Accountability and Responsibility of Engineers towards society. [16]
3. Give an account of 'Computer Ethics' and the problems associated with the autonomous nature of computers. [16]
4. Explain in detail –  
(a) values (b) ethics (c) value time (d) courage [4+4+4+4]
- 5.(a) What were the conclusions made by 'Gilligan' about men and women?  
(b) Mention the uses of 'Ethical Theories'. [8+8]
- 6.(a) What do you understand by 'acceptable risk'?  
(b) What is meant by 'voluntary risk'? [8+8]
- 7.(a) What is meant by 'Whistle Blowing'?  
(b) List any two limitations of 'Whistle blowing' [8+8]



Subject Code: R13108/R13

Set No - 4

I B. Tech I Semester Regular Examinations Feb./Mar. - 2014

**PROFESSIONAL ETHICS & HUMAN VALUES**

(Common to ECE, EEE, EIE, Bio-Tech, EComE, Agri.E)

Time: 3 hours

Max. Marks: 70

Question Paper Consists of **Part-A** and **Part-B**  
Answering the question in **Part-A** is Compulsory,  
Three Questions should be answered from **Part-B**

\*\*\*\*\*

**PART-A**

- 1.(i) Define utilitarianism.
- (ii) 'Safety is a product that comes with a price'. - Explain.
- (iii) Discuss the aim of 'Engineering Ethics'.
- (iv) Why should one have 'Respect for Others'?
- (v) Discuss the need to focus on 'Professional Ethics'.
- (vi) Write a short note on Industrial Standards.
- (vii) Explain the meaning of Moral Leadership.

[3+3+3+3+3+3+4]

**PART-B**

2. Discuss the relationship between professional responsibility and individual loyalty to the organization? [16]
3. What are the aspects of Engineering that make it appropriate to view Engineering projects as experiments? [16]
4. Write briefly on  
(a) Empathy  
(b) Living peacefully  
(c) Caring and Sharing  
(d) Courage [4+4+4+4]
5. Estimate the applicability of Intellectual Property Rights (IPR) to the Indian scenario. [16]
6. Write short notes on  
(a) History of Ethics  
(b) Heinz's Dilemma [8+8]
7. What are types of 'Risks'? Suggest some safety measures. [16]



I B.Tech I Semester Supplementary Examinations, Feb/Mar 2014  
C PROGRAMMING

( Common to Civil Engineering, Electrical & Electronics Engineering, Mechanical Engineering, Electronics & Communication Engineering, Computer Science & Engineering, Chemical Engineering, Electronics & Instrumentation Engineering, Bio-Medical Engineering, Information Technology, Electronics & Computer Engineering, Aeronautical Engineering, Bio-Technology, Automobile Engineering, Mining and Petroleum Technology)

Time: 3 hours

Max Marks: 75

Answer any FIVE Questions  
All Questions carry equal marks

\*\*\*\*\*

1. What is a Programming language? Classify and explain various Programming Languages [15]
2. (a) Write C program to check whether the given number is even or odd without using %(mod) operator.  
(b) Write C program to check whether the given number is palindrome or not (use if and go to statement). [7+8]
3. (a) How strings and characters are represented in an array?  
(b) Write a program to print array of characters. [6+9]
4. (a) Explain the drawbacks of linear arrays in detail.  
(b) Write a C program to calculate sum and average of array elements? [8+7]
5. (a) What is the advantage of using header files in 'C'?  
(b) Write short notes on auto and static storage classes [8+7]
6. (a) What is a pointer variable? How is a pointer variable different from an ordinary Variable?  
(b) Write a C program to read in an array of integers. Instead of using subscripting, however, employ an integer pointer that points to the elements currently being read in, and which is incremented each time. [7+8]
7. (a) How structure variable be defined as a member of another structure? Explain.  
(b) Write a program to store and print name, address, department and marks using structure. [8+7]
8. (a) Distinguish between the binary files and text files in C with suitable examples  
(b) Explain about formatted I/O in files. [7+8]

\*\*\*\*\*

**I B.Tech I Semester Supplementary Examinations, Feb/Mar 2014  
C PROGRAMMING**

( Common to Civil Engineering, Electrical & Electronics Engineering, Mechanical Engineering, Electronics & Communication Engineering, Computer Science & Engineering, Chemical Engineering, Electronics & Instrumentation Engineering, Bio-Medical Engineering, Information Technology, Electronics & Computer Engineering, Aeronautical Engineering, Bio-Technology, Automobile Engineering, Mining and Petroleum Technology)

**Time: 3 hours**

**Max Marks: 75**

**Answer any FIVE Questions  
All Questions carry equal marks**

\*\*\*\*\*

1. (a) What is a flow chart? Draw and explain various symbols used in flow chart  
(b) Differentiate algorithm with flow chart. Draw flow chart for calculating simple Interest [8+7]
2. What is if statement? Give different forms of if-else statements using syntax and flow chart notations (use suitable examples) [15]
3. (a) What is String? Explain about declaration and initialization of string in 'C' ?  
(b) How to display string with different formats? Explain with examples. [8+7]
4. (a) Write a C program to delete an element at a specified position?  
(b) Write C program find out the second highest and smallest of given array? [8+7]
5. Write program for arranging numbers in ascending order using recursion. [15]
6. What is Dynamic Memory Allocation? Mention the advantages of Memory Allocation and discuss its functions. [15]
7. (a) What is the use of type def in C? Explain with a suitable example  
(b) Explain the advantage of bit fields in C with suitable example [7+8]
8. (a) Explain about file i/o operations in C.  
(b) Write a 'C' program to append the contents of one file to another. [8+7]

\*\*\*\*\*

**I B.Tech I Semester Supplementary Examinations, Feb/Mar 2014**  
**C PROGRAMMING**

( Common to Civil Engineering, Electrical & Electronics Engineering,  
Mechanical Engineering, Electronics & Communication Engineering,  
Computer Science & Engineering, Chemical Engineering, Electronics &  
Instrumentation Engineering, Bio-Medical Engineering, Information  
Technology, Electronics & Computer Engineering, Aeronautical  
Engineering, Bio-Technology, Automobile Engineering, Mining and  
Petroleum Technology)

Time: 3 hours

Max Marks: 75

Answer any FIVE Questions  
All Questions carry equal marks

\*\*\*\*\*

1. What are assignment, arithmetic, relational and logical operations in C?  
Give examples. [15]
2. (a) Write a C program to find whether the given number is Armstrong number or not. (Armstrong number is a number such that the sum of digits raised to the third power is equal to the number itself. Ex.  $371=3^3+7^3+1^3=371$ )  
(b) Write a C program to print squares of odd numbers up to given integer. [8+7]
3. (a) Write briefly about the nested for loop statement. Write a program to generate multiplication table.  
(b) Explain about event and counter controlled loops. [9+6]
4. (a) Write a C program to display names of days of week using single-dimensional array.  
(b) Write C program to insert an element in an array at a specified position?  
[8+7]
5. (a) Write a C program to send and receive value from the user defined function.  
(b) What are the standard header files used in 'C'. Explain their functions. [7+8]
6. (a) Write short notes on Pointer arithmetic.  
(b) How to use pointers in expression. Explain. [7+8]
7. Write a program using a pointer to structure illustrating the initialization of the members in the structure, using different techniques to avoid floating point error problem. [15]
8. Write a program that reads a file and creates a new file with the same data, except reverse the case on the second file. Everywhere uppercase letters appear in the first file, write lower-case letters to the new file, and everywhere lowercase letters appear in the first file, and write uppercase letters to the new file. [15]

\*\*\*\*\*

I B.Tech I Semester Supplementary Examinations, Feb/Mar 2014  
C PROGRAMMING

( Common to Civil Engineering, Electrical & Electronics Engineering, Mechanical Engineering, Electronics & Communication Engineering, Computer Science & Engineering, Chemical Engineering, Electronics & Instrumentation Engineering, Bio-Medical Engineering, Information Technology, Electronics & Computer Engineering, Aeronautical Engineering, Bio-Technology, Automobile Engineering, Mining and Petroleum Technology)

Time: 3 hours

Max Marks: 75

Answer any FIVE Questions  
All Questions carry equal marks

\*\*\*\*\*

1. (a) What is the need of escape sequence? Write a sample program using any four escape sequence.  
(b) What are the different character sets available in 'C'? [8+7]
2. (a) Write a C program to check whether a number is positive or negative  
(b) Explain about multi-way selection in 'C' with a sample program. [8+7]
3. (a) Explain about standard String functions with examples?  
(b) Write C program convert the uppercase string to lowercase? Without using string function. [8+7]
4. Write a program to find rank of a matrix. [15]
5. What is a Function? What are the different types of functions? Explain function with no argument and no return type with an example. [15]
6. (a) Explain the concept of passing strings to functions as dynamic arrays with a program.  
(b) Describe about **pointers to pointers** in 'C'. [15]
7. (a) How to declare a **union** in C explain with an example  
(b) How to access the elements of a **union** explain with an example [7+8]
8. (a) Write a C program to count the number of characters in a file.  
(b) Write a C program to count the number of words in a file. [8+7]

\*\*\*\*\*