

# Design of Home Automation using Arduino

A.V.S.LAKSHMI<sup>1</sup>  
ASSISTANT PROFESSOR

B.SOWJANYA KALYANI<sup>2</sup>  
ASSISTANT PROFESSOR

D.V.S.J.POOJITHA<sup>3</sup>  
ASSISTANT PROFESSOR

EEE DEPARTMENT  
DADI INSTITUTE OF ENGINEERING AND TECHNOLOGY  
VISAKHAPATNAM

**Abstract-**Now-a-days the technology usage has become as a part of life i.e the devices which we see in our day to day life are automatically controlled through various techniques like bluetooth,Wi-Fi, Arduino, Microcontroller etc., In this paper Arduino is used as a controller which is also known as a mini computer to control the appliances like light and fan by using a TV remote. Here TSOP1738 sensor is used to sense the signal which is received from TV remote. The main advantage in using the TSOP1738 is it can transmit the frequency signals upto 38KHz.

**Index terms-** Arduino UNO, TSOP1738, TV remote

## [1] INTRODUCTION

Wireless communication has become as a part of life, in this process bluetooth,Arduino,PC Controlled devices,DTMF(Dual Tone Multiple Frequency) are used as controllers. Arduino is an open source device which is also called as an embedded system i.e it uses both software and hardware.It has 6 Analog pins, 14 digital pins which are used as both input and output pins.The Arduino UNO board has an inbuilt Microcontroller in which the program is written by using Embedded C language in order to control the devices. Its input voltage is in between 7-12 volts, maximum current output from each pin is 40milliamperes which operates with a frequency of 16MHz.The program is written in embedded C language and it is converted to hexadecimal using compiler.The TSOP1738 sensor senses the signals and sends the code to Arduino which receives the pulse in a hexa decimal value and compares with the decoded value if the signal matches then the arduino controls the respective device.

## [2] DIFFERENT CONTROLLER METHODOLOGIES

The most efficient control methods are

1. DTMF based home automation
2. PC controlled home automation
3. ARDUINO controlled home automation
4. BLUETOOTH controlled home automation

### DTMF Controller

DTMF is called as Dual Tone Multi Frequency signalling system,in this type of controller two or more frequencies are compared which generates a DTMF tone.Hence we can control the appliances by pressing the button 1,2,3,4 and so on. The main disadvantage in this type of controller is the distance is restricted only to end points of line.

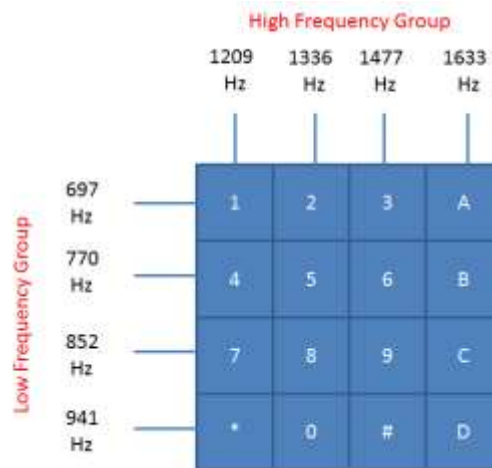

**BLUETOOTH Controller**

It is a wireless communication which enables the system using graphical user interface without cable. This type of controller operates at frequency ranges between 2402 and 2480MHz. This device is directly installed beside the conventional electrical switches so that user can communicate with this system via Bluetooth.

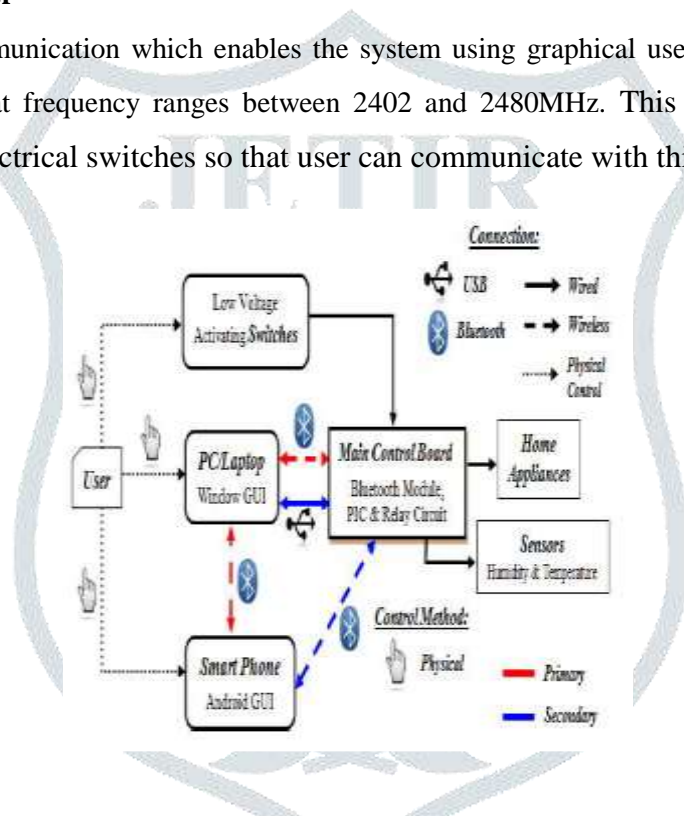

**ARDUINO Controller**

Arduino is an open-source device which consists of both a physical programmable circuit board which is also called as microcontroller and software which is also called as IDE (Integrated Development Environment) which can be used as mini computer.

**PINS OF ARDUINO**

- **GND (3):** This is GND pins on the Arduino which can be used to ground the circuit.
- **5V (4) & 3.3V (5):** Here, the 5V pin supplies 5 volts of power, and the 3.3V pin supplies 3.3 volts of power.
- **Analog (6):** This pin can read the signal from an analog sensor and convert it into a digital value that we can read.
- **Digital (7):** These pins can be used as both digital input and digital output.

- **PWM (8):** These pins act as normal digital pins, but can also be used for something called Pulse-Width Modulation (PWM).
- **RESET BUTTON:** It is used to restart any code that is loaded on the Arduino.
- **POWER LED INDICATOR:** This LED indicator is used to know check the power supply for Arduino. If this light doesn't turn on, then we need to re-check the circuit.
- **TX RX LEDs:** TX is known as transmitter, RX is known as receiver. These LEDs are used to know whether the Arduino is receiving or transmitting data .
- **MAIN IC :** The pin 13 is called as IC or Integrated Circuit . The main IC on the Arduino is different from board type to board type, but it is usually from the ATmega IC's from the ATMEL company.

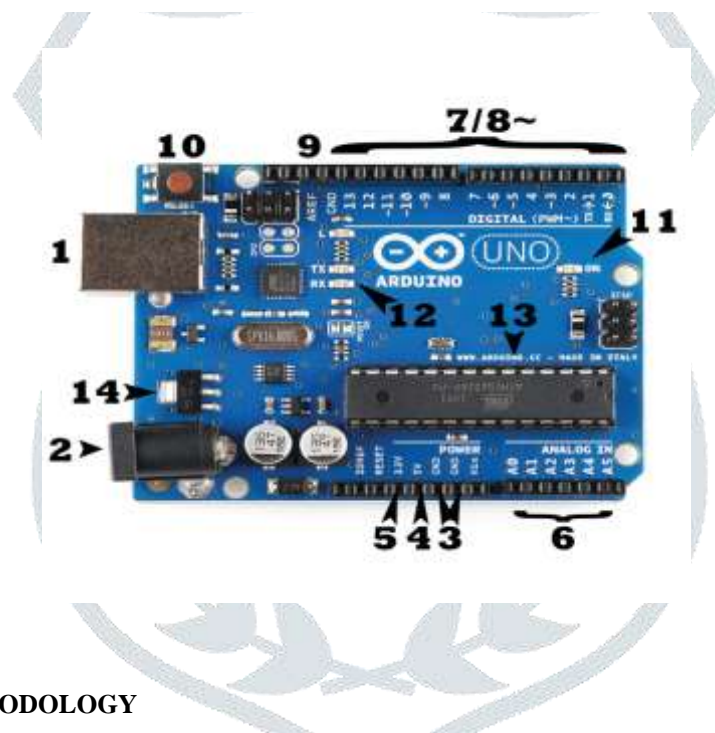

[3] PROPOSED METHODOLOGY

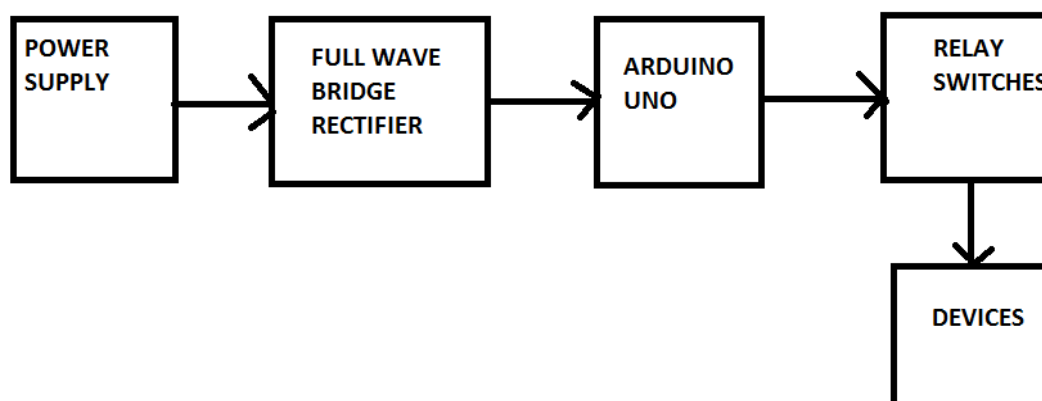

BLOCK DIAGRAM OF HOME AUTOMATION

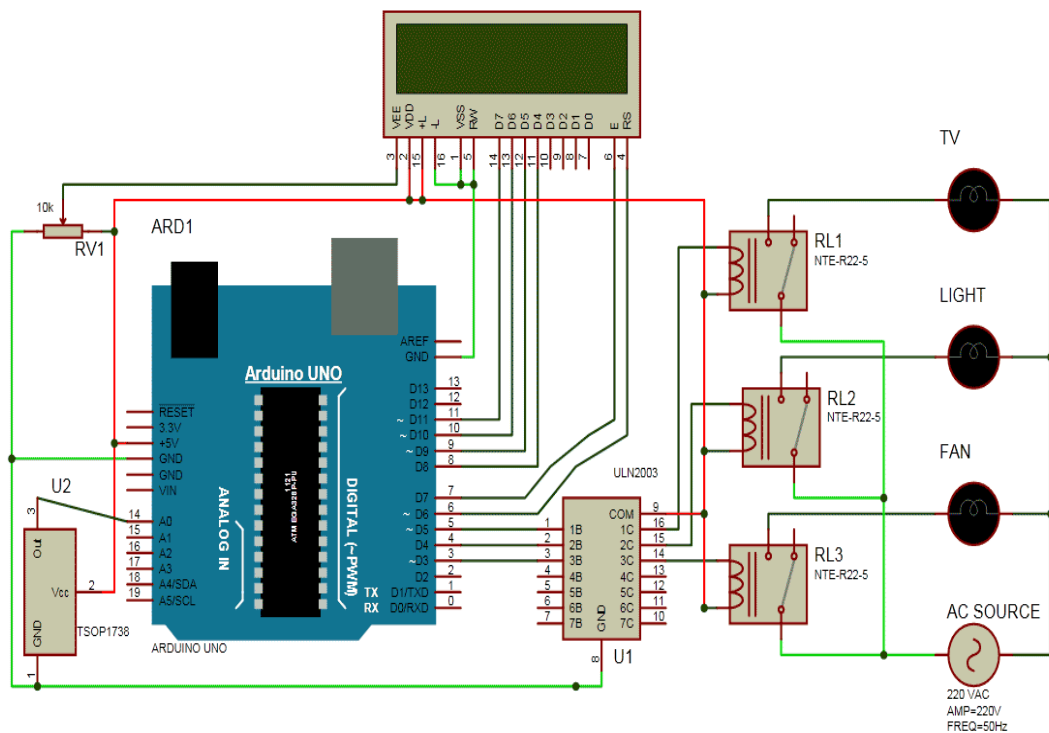

**CONNECTION DIAGRAM OF ARDUINO**

- Here the data pins of LCD namely RS, EN, D4, D5, D6, D7 are connected to arduino digital pin number 6, 7, 8, 9, 10, 11.
- The output pin of TSOP1738 is directly connected at digital pin number 14 of Arduino and Vcc pin is connected a +5 volt and GND pin connected at Ground terminal of circuit.
- A relay driver namely ULN2003 is also used for driving relays. 5 volt SPDT 3 relays are used for controlling LIGHT, FAN.
- Relays are connected to arduino pin number 3, 4 and 5 through relay driver ULN2003 which is used for controlling LIGHT and FAN.

- 1- **Single Phase Transformer:** The input to the system is given by using a step down transformer of 230/12V.
- 2- **Full Wave Bridge Rectifier:** It is used to convert the 12V AC supply to 5V DC supply, which is given as input to Arduino board.
- 3- **Arduino Board:** It acts as a controller in order to control light and fan. It is an embedded system , which is of open source device.
- 4- **Relay Switches:** These are used as sensors in order to accept the signal which is sent through arduino board.
- 5- **Devices:** The devices used here are light and fan.

### DECODED IR REMOTE:

This is also called as TV remote which is used as input device i.e by pressing the buttons ,their respective device is either ON or OFF.



#### [4] CIRCUIT IMPLEMENTATION



#### [5] CONCLUSION

In the present days the usage of technology has been increased day by day and the security has become an important role in protecting our lives. By using a smart home the devices like light, fan, Air conditioners and electronic devices are controlled by using various controllers. Hence by using the Arduino which is an open source device the home appliances light and fan are controlled. The main advantage in using arduino is its low cost when compared to other controllers.

#### REFERENCES

1. Ajah, G, David, N, Abioye, A, Web Based Security System, Sch. J. Eng. Tech, 1(3):112-116, 2013.
2. Mahmood, S M, Abdulsattar, M, Firas, A Y; Home Automation Management with WLAN (802.11g) and RF Remote Control, Raf. J. of Comp. & Math's, 6(1), 2009.
3. Aru O E ,Ihekweaba G, Opara F K, Design Exploration of a Microcontroller Based RF Remote Control 13amps Wall Socket, IOSR-JCE, 11(1), 56-60, 2013.
4. David, N, Design of an Internet Based Security System, NIJOTECH, 29(2) 118-129, 2010.
5. Daa, M F, Mahmood, B M, Data Acquisition of Greenhouse Using Arduino, Journal of Babylon University/Pure and Applied Sciences/ No.(7)/ Vol.(22), 1908-1916, 2014.



6. Robotics D, “DHT11 Humidity & Temperature Sensor”, 2010, [www.micro4you.com/files/sensor/DHT11.pdf](http://www.micro4you.com/files/sensor/DHT11.pdf)
7. Anandan, R, Karthik, B, Kumar, K, WIRE-LESS HOME AND INDUSTRIAL AUTO-MATION SECURITY SYSTEM USING GSM, JGRCS, Volume 4, No. 4, 126-132, 2013.
8. Asif, O, Hossain, B, Hasan M, Rahman, T, Chowdhury, M, Fire-Detectors Review and Design of an Automated, Quick Responsive Fire-Alarm, 2014.

