

Voice Activated Smart Home Design and Implementation Amazon Alexa

Lakshmi Mythri Dasari¹, Addala Satyanarayana Varma¹

¹Assistant Professor, ECE, Dadi Institute of Engineering & Technology, Visakhapatnam

Abstract. Home automation is becoming popular day by day due to numerous advantages. Till now the current development shows that the home automation system is managed by Emails, texts or some other applications. However, in recent years, the field of Internet of Things (IoT) has seen significant investments made by the research community and the industry. Specifically, the Smart Home space has been a prime focus with the introduction of devices such as Amazon Echo, Google Home, Samsung Smart Things among others. The growth of an industry results in innovative, economic, and advanced solutions. In this paper, we focus on making non-smart homes smart and how to build a robust, cost-effective system that can be widely used. We power our system using Amazon Echo, Amazon's cloud services, its speech services. Arduino ESP8266 is used as the hardware component for providing smart features for non-smart homes. We describe the different components of our product and will show that our system works effectively to switch on and switch off our appliances. The voice command function will be given to control any appliances or devices at home. This will provide a better communication in automated home as compared to normal homes.

Keywords: Home Automation, Internet of Things (IoT), Amazon Echo, Alexa, non-smart, Arduino ESP8266, relay

1 Introduction

Amazon Echo is a voice enabled wireless speaker developed by amazon. The device connects to the voice-controlled intelligent personal assistant service Alexa, which responds to the name "Alexa". The device is capable of voice interaction, music playback, making to-do lists, setting alarms, streaming podcasts, playing audiobooks, and providing weather, traffic and other real-time information. It can also control several smart devices using itself as a home automation hub. Home automation is a very expensive luxury that a lot of people in India and other countries cannot afford. The objective of our product is to provide a cheap and inexpensive way to control non-smart devices using the power of voice. Amazon Echo is a smart speaker that has been developed by the Amazon Company that can

be used to play music, listen to the news and control a lot of smart devices. We use the Amazon echo to develop a skill (app) that will communicate with our Arduino micro- controller to control our devices.

Whenever we want to turn on or turn off our appliances, we ask the Amazon Echo to turn the appliance on or off.

2 Related Work

In this section, we will present the various systems available in the market and the recent advancements in the research working in this area. Most of the state-of-the-art systems today can be integrated with IFTTT recipes [7]. To give some context to the reader, IFTTT is the acronym of If This, Then That. It is an initiative in the Internet of Things space where several services can be integrated to provide a robust solution. A. Existing Products The smart home space has seen a lot of industrial investment in the recent years. The following are some of the successful smart home products available today:

Lifx Color 1000: Lifx's second-gen smart bulbs are brighter and more efficient. It has an easy-to-use app, the integrations with IFTTT and Alexa, and the fact that Lifx bulbs don't need a hub is also an advantage.

Philips Hue Wireless Dimming Kit: The Philips Hue Wireless Dimming Kit is a simple, and affordable way to get started with smart lighting. It allows you to control the lights of your home using voice and the internet. It also allows you to control the intensity of the light.

IKEA Smart Lighting Project: The Ikea TRÅDFRI skill for Alexa is also live in countries where Amazon is selling Echo devices. After enabling it, owners can ask Alexa to dim their Ikea bulbs, or turn them on and off.

3 Technology Stack

In this paper, we have integrated many technical components and established a seamless functionality among them. Our technological stack is delineated as follows [3]:

- Physical Layer: This layer comprises of the devices with which the user interaction takes place:

- 1) Arduino ESP8266 - enabled with WiFi
- 2) Amazon Echo - Smart Personal Assistant device that is present in the user's home. It is triggered using voice commands. Based on the request made, a response will be returned to the user.

- Application Layer: This layer consists of the following components:

- 1) Alexa Skills Kit (ASK)-It is a minimalist Software Development Kit (SDK) for developing "skills" for the Amazon Echo

2) Amazon Web Services(AWS) Lambda- Functionality that runs programs when invoked rather than hosting programs on a server

- Programming Layer: The source codes of all our programs are written in Arduino IDE using the customized language.

The technological stack is elaborated in the following sections.

A. Devices

The input is given through Amazon's Echo. Echovoices result from speech-unit selection technology. It is able to perceive what the user is saying using NLP algorithms built into the Echo's text-to-speech (TTS) engine. The Echo hardware complement includes a Texas Instruments DM3725 ARM Cortex-A8 processor, 256MB of LPDDR1 RAM and 4GB of storage space. It connects to the internet through WiFi 802.11a/b/g/n. The Arduino microcontroller serves as another I/O device. For this implementation, we have used Arduino ESP8266. ESP8266 Arduino core comes with libraries to communicate over WiFi using TCP and UDP, set up HTTP, mDNS, SSDP, and DNS servers, do OTA updates, use a file system in flash memory, work with SD cards, servos, SPI and I2C peripherals [6].

B. Infrastructure

Alexa voice services powers Amazon Echo by converting speech into text and giving intelligent replies to user requests. Alexa is capable of voice interaction, music playback, making to-do lists, setting alarms, streaming podcasts, playing audiobooks, and providing weather, traffic and other real-time information. Alexa can also control several smart devices using itself as a home automation hub. Amazon has released the 3 AVS API that allows Alexa to integrate with devices and applications. AWS Lambda is an event-driven, server less computing platform provided by Amazon. It is a compute service that runs code in response to events and automatically manages the compute resources required by that code. The purpose of Lambda, as compared to AWS Elastic Compute Cloud (AWS EC2), is to simplify building smaller, on-demand applications that are responsive to events and new information. AWS targets starting a Lambda instance within milliseconds of an event. Node.js, Python and Java are all officially supported languages. Moreover, choosing AWS Lambda is much more cost-efficient option in this scenario.

C. Codebase

The Arduino language is merely a set of C/C++ functions that can be called from your code. Your sketch undergoes minor changes (e.g. automatic generation of function prototypes) and then is passed directly to a C/C++ compiler (avr-g++). All standard C and C++ constructs supported by avr-g++ should work in Arduino [5]. For more details, see the page on the Arduino build process.

Code Structure:

```
void setup() {  
  //setup is called once the program is loaded
```

```

}
void loop() {
//loop continuously keeps on checking the new commands received and executes
them during the lifecycle of the program
}

```

4. System Design

Our system as shown in Figure 1 - Uses ESP8266 NodeMCU, Amazon Echo Dot and Alexa Voice Service. In this section, we will explain briefly about each component's role to make the system function.

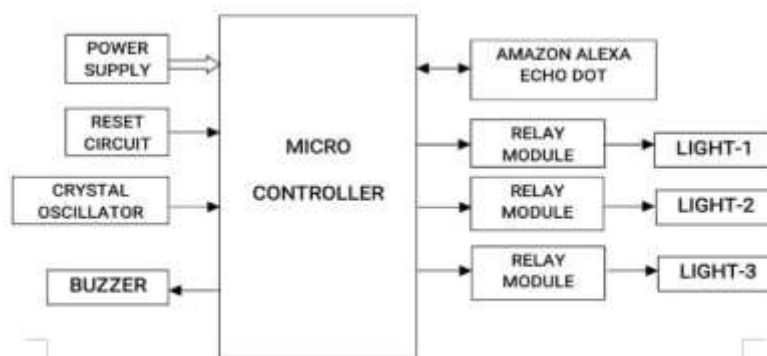

Fig 1: System Design

A. Alexa Voice Service (AVS)

Alexa Voice Service is the intelligent voice control service that powers the device, Amazon Echo. Alexa uses natural language processing techniques trained by the developers and the user community of Amazon to process user requests and cater to their individual needs. The voice service can be triggered using the keyword “Alexa”. As mentioned earlier, the skill/application that we have developed can be triggered using the voice command, “Alexa, Turn the lights on”. Once Alexa is triggered, it runs a script on the cloud, which in-turn runs a subroutine on the NodeMCU to Switch on the light. Once computation is done in the NodeMCU, it sends the confirmation back to Alexa. Only the essential information is sent to Alexa which passes it on back to the user.

B. ESP8266 - Arduino Microcontroller

The ESP8266 is the name of a micro controller designed by Espressif Systems. The ESP8266 itself is a self-contained WiFi networking solution offering as a bridge from existing micro controller to WiFi and is also capable of running self-contained applications. This module comes with a built in USB connector and a rich assortment of pin-outs. With a micro USB cable, you can connect NodeMCUdevkit to your laptop and flash it without any trouble, just like Arduino. It is also immediately breadboard friendly.

The most basic way to use the ESP8266 module is to use serial commands, as the chip is basically a WiFi/Serial transceiver[8]. However, this is not convenient. What we recommend is using the very cool Arduino ESP8266 microcontroller, which is a modified version of the Arduino IDE that you need to install on your computer. This makes it very convenient to use the ESP8266 chip as we will be using the well-known Arduino IDE.

C. Amazon Echo Dot

Echo Dot connects to dual-band Wi-Fi (2.4 GHz / 5 GHz) networks that use the 802.11a / b / g / n standard. Echo Dot does not connect to ad-hoc (or peer-to-peer) networks.

5. Simulation

Platform and Language Used:

- 1) IoT platform for Pub Sub Services
- 2) The Arduino language and Arduino IDE
- 3) Amazon Alexa android application

Working Methodology

- Connect Amazon Echo Dot device to the Wi-Fi network.
- Connect NodeMCU ESP8266 to the USB port; make sure that ESP8266 MCU is connected to the same wi- fi network to which the Echo Dot device is connected.
- Verify Serial Connector logs to ensure that wi-fi connection has been established successfully.
- Supply power to the smart lights/appliances connected to relay socket.
- The setup is complete, and Alexa is ready to take and follow instructions to control your smart home.

6. Conclusion & Future Scope

As discussed in the earlier section even though there is abundance of smart

appliances available in the market it is not feasible for the Indian market since it is very expensive. Our product makes it viable for the market since it is an easy and affordable and can be used with any appliance.

The smart home space has a lot of interesting challenges to be solved. One very important problem that we tried to address in this paper is that of non-smart. We made use of one of the hottest smart devices available today in the market, Amazon Echo and coupled it with the Arduino NodeMCU. The module we used for performing home automation tasks worked well. Further, on testing the application on Amazon Echo in real-time, we obtained promising results. We believe that this step towards a cost-effective smart home. We aim to build similar applications in the future for Google Home and other personal assistants that can revolve around using simple voice commands to provide a cost-effective solution for non-smart homes.

Acknowledgements. The authors would like to express their deepest gratitude to Sri Dadi Ratnakar, Chairman of Dadi Institute of Engineering & Technology for his encouragement and support in executing this work successfully.

References

- [1] Kumar, M., and Shimi, S. L. "Voice Recognition Based Home Automation System for Paralyzed People System", Vol. 4, No. 10, 2015
- [2] NorhafizahbtAripin, M. B. Othman, "Voice control of home appliances using Android", Electrical Power Electronics Communications Controls and Informatics Seminar (EECCIS) 2014, pp. 142-146, 2014
- [3] Tatjana Eric, Sandra Ivanovic, SuncicaMilivojsa, "Voice control for smart home automation: Evaluation of approaches and possible architectures", Internet of Things Journal IEEE, Sept 2017
- [4] KalyaniPampattiwar, MitLakhani, RinishaMarar and Rhea Menon, "Home Automation using Raspberry Pi controlled via an Android Application", International Journal of Current Engineering and Technology, 2017
- [5] Arduino - Home: www.arduino.cc
- [6] ESP8266 Community Forum: <http://www.esp8266.com/>
- [7] <https://ifttt.com/>
- [8] Prof B.P Kulkarni, Aniket V Joshi, Vaibhav V Jadhav, Akshaykumar T Dhamange, "IoT Based Home Automation Using Raspberry PI", International Journal of Innovative Studies in Sciences and Engineering Technology, Vol. 3 Issue 4 April 2017
- [9] J.Chandramohan, R.Nagarajan, K.Satheeshkumar, N.Ajithkumar, P.A.Gopinath, S.Ranjithkumar6, "Intelligent Smart Home Automation and Security System Using Arduino and Wi-fi", International Journal Of Engineering And Computer Science, Vol. 6 Issue 3 March 2017