



# DADI INSTITUTE OF ENGINEERING & TECHNOLOGY

(Approved by A.I.C.T.E., New Delhi & Affiliated to JNTUK, Kakinada)

NAAC Accredited Institute

An ISO 9001:2008, ISO 14001:2004 & OHSAS 18001:2007 Certified Institute.

NH-5, Anakapalle – 531002, Visakhapatnam, A.P.

Phone: 08924-221111 / 221122/9963981111, www.diet.edu.in, E-mail: [info@diet.edu.in](mailto:info@diet.edu.in)

## I B.TECH Question Bank

Subject : Mathematics-III Branch: EEE, CIVIL.

Faculty: Prof.Dr.Ch.Prabhakara Rao.

### UNIT -I

1(a) Find the rank of the matrix by reducing the matrix  $A = \begin{bmatrix} 2 & 1 & 3 & 4 \\ 0 & 3 & 4 & 1 \\ 2 & 3 & 7 & 5 \end{bmatrix}$  to canonical form .

(b) prove that the following set of equations are consistent and solve them.

$$2x - y - z = 2 ; x + 2y + z = 2 ; 4x - 7y - 5z = 2 ;$$

2(a) Find the currents in the following circuits

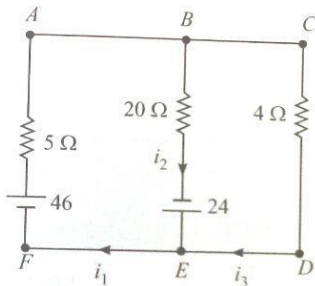

(b) solve the system of equations  $10x + y + z = 12$ ,  $2x + 10y + z = 13$  and  $2x + 2y + 10z = 14$  using Gauss-seidel method.

3(a) Find the non singular matrices P and Q such that the normal form of A is PAQ where

$$A = \begin{bmatrix} 1 & 3 & 6 & -1 \\ 1 & 4 & 5 & 1 \\ 1 & 5 & 4 & 3 \end{bmatrix}. \text{ Hence find its rank.} \quad 5M$$

(b) Find the rank of  $\begin{pmatrix} 2 & 3 & -1 & -1 \\ 1 & -1 & -2 & -4 \\ 3 & 1 & 3 & -2 \\ 6 & 3 & 0 & -7 \end{pmatrix}$  after reducing it to Echelon form

5(a) Solve the system of equations  $20x + y - 2z = 17, 3x + 20y - z = -18, 2x - 3y + 20z = 25$  by Gauss Jacobi method

(b) Reduce the matrix A to normal form and hence find the rank of the matrix

$$A = \begin{bmatrix} 2 & -2 & 0 & 6 \\ 4 & 2 & 0 & 2 \\ 1 & -1 & 1 & 2 \end{bmatrix}$$

6(a) Solve the equations  $3x + y + 2z = 3, 2x - 3y - z = -3, x + 2y + z = 4$  using Gauss elimination method.

(b) Find the currents in the following circuits

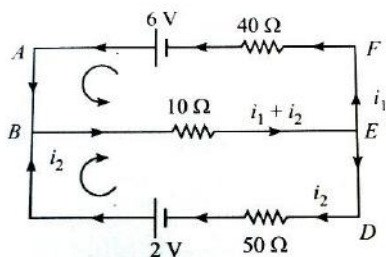

## UNIT – II:

1(a) Find Eigen values and Eigen vectors of  $\begin{bmatrix} 6 & -2 & 2 \\ -2 & 3 & -1 \\ 2 & -1 & 3 \end{bmatrix}$  5M

(b) Reduce the quadratic form  $10x^2 + 2y^2 + 5z^2 - 4xy - 10xz + 6yz$  into canonical form and find the nature, rank, index and signature. 5M

2(a) Reduce the Quadratic form  $3x_1^2 + 3x_2^2 + 3x_3^2 + 2x_1x_2 + 2x_1x_3 - 2x_2x_3$  into sum of squares form by an orthogonal transformation and give the matrix transformation.

(b) Find  $A^{-1}$  using Cayley –Hamilton theorem, where  $A = \begin{bmatrix} 1 & 2 & 3 \\ 2 & 4 & 5 \\ 3 & 5 & 6 \end{bmatrix}$  6M

3(a) what is the nature of the quadratic form  $X^TAX$ , if  $A = \begin{bmatrix} 1 & 1 & 3 \\ 1 & 5 & 1 \\ 3 & 1 & 1 \end{bmatrix}$  4M

(b) Prove that if  $\tau$  is an Eigen value of a matrix A then  $\tau^{-1}$  is an Eigen value of matrix  $A^{-1}$  if it exists.

4(a) If  $\tau$  is an Eigen value of a non singular matrix A then show that  $\frac{|A|}{\tau}$  is an Eigen value of matrix adjoint A(adjA)

(b) Find  $A^{-1}$  using Cayley-Hamilton theorem, where  $A = \begin{bmatrix} 1 & 2 & -1 \\ 2 & 1 & -2 \\ 2 & -2 & 1 \end{bmatrix}$  6M

5(a) state Cayley-Hamilton theorem and find  $A^8$  if  $A = \begin{pmatrix} 1 & 2 \\ 2 & -1 \end{pmatrix}$

(b) Diagonalize the matrix  $\begin{bmatrix} 2 & 2 & 1 \\ 1 & 3 & 1 \\ -1 & 2 & 2 \end{bmatrix}$  6M

6(a) Show that if  $\lambda$  is an eigen value of A, then prove that the eigen value of

$B = a_0A^2 + a_1A + a_2I$  is  $a_0\lambda^2 + a_1\lambda + a_2$ . 4M

(b) Is the matrix  $\begin{bmatrix} 3 & 10 & 5 \\ -2 & -3 & -4 \\ 2 & 5 & 7 \end{bmatrix}$  diagonalizable? 6M

### UNIT -III :

1(a) Find surface area of the right circular cone generated by the revolution of right angled triangle about a side which contains a right angle. 4M

(b) Evaluate  $\int_0^1 \int_{x^2}^{2-x} xy dx dy$  by changing the order of integration. 6M

2(a) Find the volume of the solid generated by revolving the ellipse  $\frac{x^2}{a^2} + \frac{y^2}{b^2} = 1$  ( $0 < b < a$ ) about the major axis. 5M

(b) By changing the order of integration, evaluate  $\int_0^1 \int_0^{\sqrt{1-x^2}} y^2 dx dy$  5M

3(a) Find the moment of inertia about the initial line of the cardioid  $r = a(1 - \cos\theta)$ . 5M

(b) Find the surface area generated by the revolution of an arc of the catenary  $y = c \cosh \frac{x}{c}$  about x-axis. 5M

4(a) Find the length of the curve  $3x^2 = y^3$  between  $y = 0$  and  $y = 1$ . 5M

(b) Find the volume obtained by revolving the loop of the curve  $x = t^3, y = t - \frac{t^3}{3}$  about x-axis. 5M

5(a) Trace the curve  $r = a + b \cos\theta$ ,  $a > b$ . 4M

(b) Find the length of the arc of the parabola  $y^2 = 4ax$  measured from the vertex to both extremities of the latus-rectum. 6M

6(a) Evaluate  $\int_0^a \int_x^a (x^2 + y^2) dy dx$  by changing the order of integration. 5M

(b) Evaluate  $\iint (x^2 + y^2) dx dy$  in the positive quadrant for which  $x + y \leq 1$ . 5M

## UNIT – IV:

- 1(a) Show that  $\int_0^{\infty} \sqrt{x} e^{-x^3} dx = \frac{\sqrt{\pi}}{3}$  4M
- (b) Show that  $\int_0^{\infty} x^m e^{-ax^n} dx = \frac{1}{na} \frac{\Gamma(\frac{m+1}{n})}{n}$  where m and n are positive constants. 6M
- 2(a) Prove that  $\Gamma\Gamma(n)\Gamma\Gamma(n-1) = \frac{\pi}{\sin n\pi}$  4M
- (b) Express  $\int_0^1 x^m (1-x^n)^p$  in terms of  $\Gamma$  function. 6M
- 3(a) Evaluate  $\int_0^1 \frac{dx}{(1-x^3)^{1/3}}$  using Beta functions. 4M
- (b) Evaluate  $\int_5^7 (x-5)^6 (7-x)^3 dx$  using  $\beta$  and  $\Gamma\Gamma$  functions. 6M
- 4(a) Show that  $\Gamma(\frac{1}{2}) = \sqrt{\pi}$  4M
- (b) Show that  $B(m, n) = \frac{\Gamma(m)\Gamma(n)}{\Gamma(m+n)}$  where  $m > 0, n > 0$ . 6M
- 5(a) Evaluate  $\int_0^{\pi/2} \sin^5 \theta \cos^{7/2} \theta d\theta$ . 4M
- (b) Evaluate  $\int_0^1 x^4 \left(\log \frac{1}{x}\right)^3 dx$  6M
- 6(a) Evaluate  $\int_0^1 \frac{xdx}{\sqrt{1-x^2}}$ . 4M
- (b) Evaluate  $\int_0^{\infty} x^2 e^{-x^2} dx$ . 6M

## UNIT- V :

- 1(a) If  $\phi$  satisfies Laplace equation, show that  $\nabla\phi$  is both Solenoidal and irrotational. 4M
- (b) Prove that  $div.(grad r^m) = m(m+1)r^{m-2}$  6M
- 2(a) Find the angle between the surfaces  $x^2 + y^2 + z^2 = 9$  and  $z = x^2 + y^2 - 3$  at the point (2, -1, 2). 4M
- (b) If  $\vec{A}$  is irrotational, evaluate  $div(\vec{A} \times \vec{r})$  where  $\vec{r} = x\vec{i} + y\vec{j} + z\vec{k}$  6M
- 3(a) Find  $div\vec{F}$ , where  $\vec{F} = r^n \vec{r}$ . Find n if it is solenoidal. 4M
- (b) Find a, b, c so that  $\vec{A} = (x + 2y + az)\vec{i} + (bx - 3y - z)\vec{j} + (4x + y + 2z)\vec{k}$  is irrotational. also find  $\phi$  such that  $\vec{A} = \nabla\phi$  6M
- 4(a) In what direction from the point (-1, 1, 2) is the directional derivative of  $\phi = xy^2z^3$  a maximum. What is the magnitude of this maximum? 4M

(b) Show that the vector  $(x^2 - yz)\bar{i} + (y^2 - zx)\bar{j} + (z^2 - xy)\bar{k}$  is irrotational and find its scalar potential. 6M

5(a) Find the directional derivative of  $\frac{1}{r}$  in the direction of  $\bar{r} = xi + yj + zk$  at  $(1, 1, 2)$  4M

(b) Prove that  $div(\bar{a} \times \bar{b}) = \bar{b} \cdot curl\bar{a} - \bar{a} \cdot curl\bar{b}$  6M

6(a) Find the directional derivative of the function  $\phi = xy^2 + yz^3$  at  $(2, -1, 1)$  in the direction of normal to the surface  $x \log z - y^2 = 4 = 0$  at  $(-1, 2, 1)$  4M

(b) Show that  $\frac{\bar{r}}{r^3}$  is solenoidal, where  $\bar{r} = x\bar{i} + y\bar{j} + z\bar{k}$  6M

### UNIT – VI:

1(a) Use Greens theorem to evaluate  $\int (2xy - x^2)dx + (x^2 + y^2)dy$ , where c is the closed curve of the region bounded by  $y = x^2$  and  $y^2 = x$ . 4M

(b) Use divergence theorem to evaluate  $\iint \bar{F} \cdot d\bar{s}$  where  $\bar{F} = 4x\bar{i} - 2y^2\bar{j} + z^2\bar{k}$  and S is the surface bounded by the region  $x^2 + y^2 = 4, z = 0$  and  $z = 3$ . 6M

2(a) Evaluate  $\int (e^x dx + 2ydy - dz)$  where c is the curve is the curve is the curve  $x^2 + y^2 = 9, z = 2$ , by using Stoke's theorem. 5M

(b) Compute  $\int (ax^2 + by^2 + cz^2)d\bar{s}$  over the surface of the sphere  $x^2 + y^2 + z^2 = 1$ . 5M

3(a) If  $\bar{F} = (5xy - 6x^2)\bar{i} + (2y - 4x)\bar{j}$ , evaluate  $\int \bar{F} \cdot d\bar{r}$  along the curve c in xy plane :  $y = x^3$  from  $(1, 1)$  to  $(2, 8)$ . 4M

(b) Apply stoke's theorem to evaluate  $\int (ydx + zdy + xdz)$  where c is the curve of intersection of the sphere  $x^2 + y^2 + z^2 = a^2$  and  $x + z = a$ . 6M

4(a) Using stoke's theorem, evaluate the integral  $\int \bar{F} d\bar{r}$ , where  $\bar{F} = 2y^2\bar{i} + 3x^2\bar{j} - (2x + z)\bar{k}$  and c is the boundary of the triangle whose vertices are  $(0,0,0), (2,0,0)$  and  $(2,2,0)$ . 4M

(b) Using divergence theorem to evaluate  $\iint \bar{F} \cdot d\bar{s}$  where  $\bar{F} = x^3\bar{i} + y^3\bar{j} + z^3\bar{k}$  and S is surface of the sphere  $x^2 + y^2 + z^2 = r^2$ . 6M

5(a) If  $\bar{F} = (2x^2 - 3z)\bar{i} - 2xy\bar{j} - 4x\bar{k}$  then evaluate  $\iiint \nabla \cdot \bar{F} dv$  where v is the closed region bounded by  $x=0, y=0, z=0$  and  $2x+2y+z=4$ . 5M

(b) Evaluate by Green's theorem  $\oint (y - \sin x)dx + \cos x dy$  where C is the triangle enclosed by the lines  $y = 0, x = \frac{\pi}{2}, \pi y = 2x$ . 5M

6(a) If  $\bar{F} = xy\bar{i} - z\bar{j} + x^2\bar{k}$  and C is the curve  $x = t^2, y = 2t$  and  $z = t^3$  from  $t = 0$  to  $t = 1$ , find the workdone by  $\bar{F}$ . 4M

(b) Compute the line Intergral  $\int (y^2 dx - x^2 dy)$  round the triangle whose vertices are  $(1,0), (0,1)$  and  $(-1,0)$ . 6M

# DADI INSTITUTE OF ENGINEERING & TECHNOLOGY



(Approved by A.I.C.T.E., New Delhi & Affiliated to JNTU, Kakinada)

**NAAC Accredited Institute**

An ISO 9001:2008; ISO 14001:2004 & OHSAS 18001:2007 Certified Institution

NH-5, Anakapalle – 531002, Visakhapatnam, A.P.

Phone: 08924-221111 / 221122/9963981111, e-mail: [info@diet.edu.in](mailto:info@diet.edu.in)

Academic Year : **2017 – 2018**  
Name of the Faculty : **M.RAJARAO**  
Designation : **Assistant Professor**  
Department : **Electrical & Electronics Engineering**  
Year/Semester : **Ist Year/II nd semester**  
Subject : **ECA-1**

## UNIT-1

- (A) Obtain the expressions for star-delta and delta-star equivalence of resistive network  
(b) Find the value of resistance R, if the current is  $I=11$  A and source voltage is 66 V as shown in fig

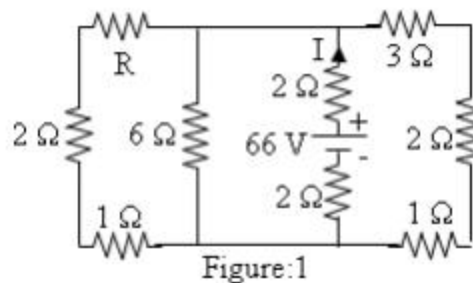

- (A) State and explain KVL and KCL with the help of an example.  
(b) Four 60 W, 110 V bulbs are to be operated from a 230 V source. Determine the value of resistance connected in series with the line so that the voltage across the bulb does not exceed 110 V.  
(c) Two resistances when they are in series have an equivalent resistance of 9 ohms and when connected in parallel have an equivalent resistance of 2 ohms. Find the resistances and ratio of voltage and current sharing between the elements if the supply voltage is 50 V.
- (a) Find the average value, r.m.s value, form factor and peak factor for the wave form shown in figure:1.

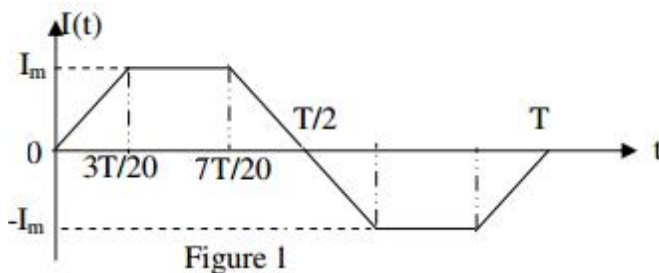

# DADI INSTITUTE OF ENGINEERING & TECHNOLOGY

(Approved by A.I.C.T.E., New Delhi & Affiliated to JNTU, Kakinada)



**NAAC Accredited Institute**

An ISO 9001:2008; ISO 14001:2004 & OHSAS 18001:2007 Certified Institution

NH-5, Anakapalle – 531002, Visakhapatnam, A.P.

Phone: 08924-221111 / 221122/9963981111, e-mail: [info@diet.edu.in](mailto:info@diet.edu.in)

(b) Use the nodal analysis to determine voltage at node 1 and the power supplied by the dependent current source in the network shown in figure:2.

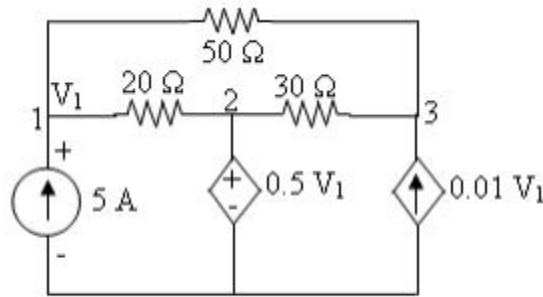

Figure:2

4. (a) Prove that pure capacitance when connected across an alternating source draws the current leading over voltage by 90°. Show that power consumed by pure capacitance is zero

(b) Find the values of the voltages  $V_1$  and  $V_2$  in the circuit shown in figure:1.

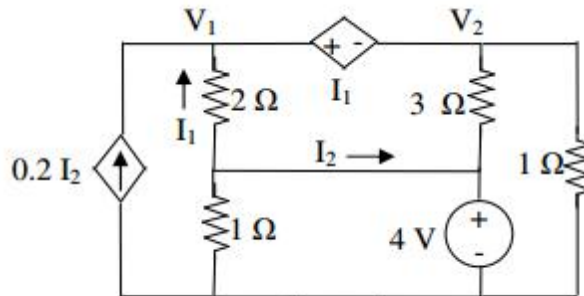

Figure:1

## UNIT-2

1 (a) Write the properties of tie-set matrix and cut-set matrix.

(b) Draw the graph of the network shown in figure:2 and select a suitable tree to write a tie-set Schedule. Also find the three loop currents.

# DADI INSTITUTE OF ENGINEERING & TECHNOLOGY

(Approved by A.I.C.T.E., New Delhi & Affiliated to JNTU, Kakinada)

**NAAC Accredited Institute**

An ISO 9001:2008; ISO 14001:2004 & OHSAS 18001:2007 Certified Institution

NH-5, Anakapalle – 531002, Visakhapatnam, A.P.

Phone: 08924-221111 / 221122/9963981111, e-mail: [info@diet.edu.in](mailto:info@diet.edu.in)

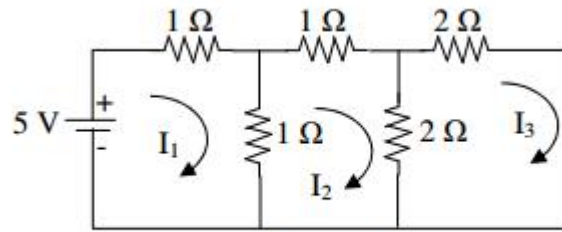

Figure:2

2 (a) find fundamental tie-set and cut-set matrix for the graph and its tree shown in figure:5.

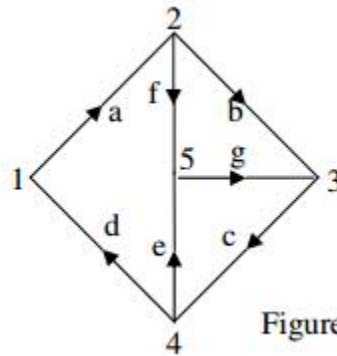

Figure:5

(b) Explain the procedure for obtaining fundamental cut-set matrix of given network.

3.(a) Describe the procedure to construct the dual of a network with an example.

(b) For the network graph shown in figure:2, draw all possible trees. For any one of these trees, prepare a cut-set schedule and obtain the relation between tree-branch voltages and branch voltages.

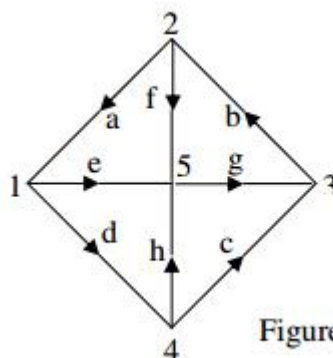

Figure:2



# DADI INSTITUTE OF ENGINEERING & TECHNOLOGY



(Approved by A.I.C.T.E., New Delhi & Affiliated to JNTU, Kakinada)

**NAAC Accredited Institute**

An ISO 9001:2008; ISO 14001:2004 & OHSAS 18001:2007 Certified Institution

NH-5, Anakapalle – 531002, Visakhapatnam, A.P.

Phone: 08924-221111 / 221122/9963981111, e-mail: [info@diet.edu.in](mailto:info@diet.edu.in)

4.(a) Explain the procedure for obtaining fundamental tie-set matrix of given network.

(b) Draw the oriented graph of a network with fundamental cut-set matrix as shown below:

Twigs				Links		
1	2	3	4	5	6	7
1	0	0	0	-1	0	0
0	1	0	0	1	0	1
0	0	1	0	0	1	1
0	0	0	1	0	1	0

Also find number of cut-sets and draw them.

## UNIT-3

1.(a) Two identical coupled coils have an equivalent inductance of 80 mH when connected series aiding and 35 mH in series opposing. Find  $L_1$ ,  $L_2$ ,  $M$  and  $K$

(b) A ring has a mean diameter of 21 cm and cross sectional area of 10 cm<sup>2</sup>. The ring is made up of semi-circular sections of cast iron and cast steel with each joint having reluctance equal to an air gap of 0.2 mm. Find the ampere turns required to produce a flux of 0.8 milli Wb. The relative permeability of cast steel and cast iron are 800 & 166 respectively. Neglect fringing and leakage effects.

2.(a) Two coupled coils with respect to self inductances  $L_1 = 0.6$  H,  $L_2 = 0.4$  H having a  $K = 0.4$ .

Coil 2 has 100 turns. The current in coil 1 is  $i_1 = 10 \sin 200t$  Amperes. Determine the voltage at coil 2 and maximum flux set up by coil 1.

(b) What is a magnetic circuit? Compare magnetic circuit with an electric circuit.

(c) Derive the relation between self inductance, mutual inductance and coefficient of coupling.

3.(a) Explain the importance of dot convention in coupled circuits.

(b) State and explain Faraday's laws of electromagnetic induction.

(c) With respect to series resonant circuit, prove that bandwidth is inversely proportional to the Q-factor at resonance.

4 a) Define: (i) Flux (ii) m.m.f (iii) Reluctance (iv) Magnetic field intensity.

# DADI INSTITUTE OF ENGINEERING & TECHNOLOGY

(Approved by A.I.C.T.E., New Delhi & Affiliated to JNTU, Kakinada)



NAAC Accredited Institute

An ISO 9001:2008; ISO 14001:2004 & OHSAS 18001:2007 Certified Institution

NH-5, Anakapalle – 531002, Visakhapatnam, A.P.

Phone: 08924-221111 / 221122/9963981111, e-mail: [info@diet.edu.in](mailto:info@diet.edu.in)

(b) A coil is wound uniformly with 400 turns over an iron ring having a mean circumference of 50 cm and a cross section of 0.4 cm<sup>2</sup>. If the coil has resistance of 10 ohm and is connected across a 50 V DC supply, calculate the m.m.f of the coil, magnetic field strength, magnetic field density, total flux and reluctance of the ring.

5.(a) A mild steel ring has a mean circumference of 600 mm and a uniform cross-sectional area of 350 mm<sup>2</sup>. Calculate the m.m.f required producing a flux of 600Wb when an air gap of 1mm length is now cut in ring. Also determine the flux produced if m.m.f remains constant. Given relative permeability of mild steel is 1200.

## UNIT-4

1(a) A resistance R, L=0.02H and capacitance C connected series. When a voltage  $V=200\cos(2000t-20)$  volts is applied to the series combination, the current flowing is  $5\sqrt{2}\cos(2000t-65)$  amps, find R & C.

. b) For the circuit shown in Figure, determine the total impedance, total current and phase angle

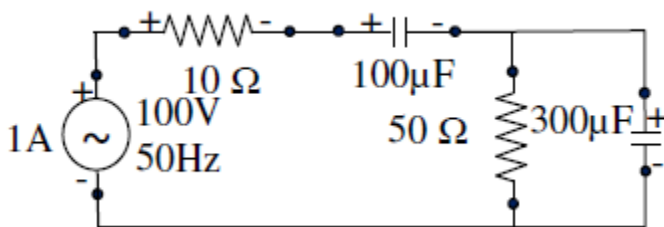

c) Discuss about Power triangle and power factor in ac circuits

2. (a) Explain the procedure to draw the locus diagram of R-L series circuit when L is varying?

(b) A coil of inductance 0.0805 H takes a current of 5 A when connected in series with a 50 Floss-free capacitor across a 240 V, 50 Hz supply. Calculate (i) resistance of the coil (ii) power factor of the coil (iii) the overall power factor. Sketch the phasor diagram.

(c) Define form factor and peak factor of an alternating quantity.

# DADI INSTITUTE OF ENGINEERING & TECHNOLOGY

(Approved by A.I.C.T.E., New Delhi & Affiliated to JNTU, Kakinada)



NAAC Accredited Institute

An ISO 9001:2008; ISO 14001:2004 & OHSAS 18001:2007 Certified Institution

NH-5, Anakapalle – 531002, Visakhapatnam, A.P.

Phone: 08924-221111 / 221122/9963981111, e-mail: [info@diet.edu.in](mailto:info@diet.edu.in)

3.(a) Explain the procedure to draw the locus diagram of R-C series circuit when 'C' is varying.

(b) An R- L circuit has  $R= 1$  ohms,  $L=0.00955$  H. Calculate the value of series capacitor which converts the circuit to a R-L-C series circuit taking double the value of original current. Assume 50 Hz supply. Supply voltage is kept constant

(c) Explain why current leads the voltage by  $90^\circ$  in case of ideal capacitor.

(D) Define active and reactive power of alternating quantity and write their expressions

4(a) A coil having a resistance of 20 ohms and an inductance of 0.2 H is connected in series with a  $50 \mu\text{F}$  capacitor across a 250 V, 50 Hz supply. Calculate (i) the current (ii) the power (iii) the power factor (iv) the voltage across the coil and capacitor. Draw the phasor diagram showing the current and various voltages.

(b) Explain why current lags the voltage by  $90^\circ$  in case of ideal inductor.

(c) What is power factor? What is its significance?

5(a) The resistance of a coil is  $140\Omega$  and its inductance 0.85 H. Determine the current, the p.f. and the circuit impedance when the coil is connected to 120 V 60 Hz supply.

(b) Find the RMS value of the current waveform of Figure . If the current flows through a 9 ohm resistor, calculate the average power absorbed by the resistor

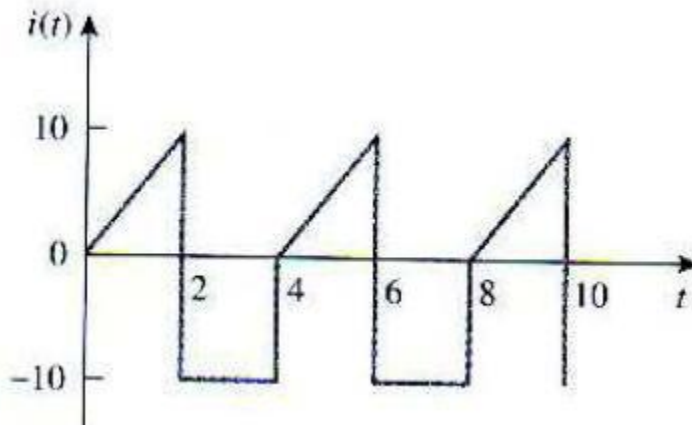

(c) A choke coil and a resistor are connected in series across a 230V, 50 Hz ac supply as shown in below Figure 6. The circuit draws a current of 2A at 0.866 lag p.f. The voltage drop across the resistor is 100V. Calculate the p.f of the choke coil

# DADI INSTITUTE OF ENGINEERING & TECHNOLOGY

(Approved by A.I.C.T.E., New Delhi & Affiliated to JNTU, Kakinada)



NAAC Accredited Institute

An ISO 9001:2008; ISO 14001:2004 & OHSAS 18001:2007 Certified Institution

NH-5, Anakapalle – 531002, Visakhapatnam, A.P.

Phone: 08924-221111 / 221122/9963981111, e-mail: [info@diet.edu.in](mailto:info@diet.edu.in)

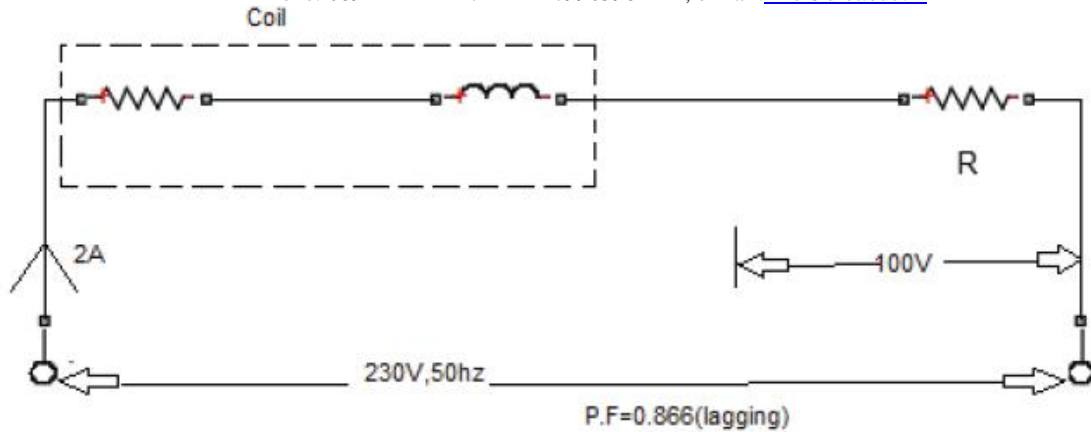

- 6(a) A coil has an impedance of  $320+600j$ . The current through the coil is  $(3-5j)$  mA. Find the voltage of the coil, active and reactive power of the coil.
- (b) Find the RMS value of the current waveform of Figure 4. If this current flows through a 9ohm resistor, calculate the average power absorbed by the resistor.

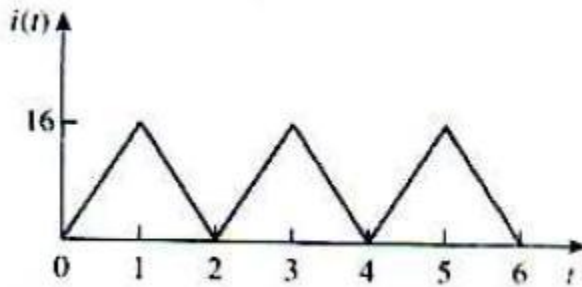

## UNIT-5

- 1 (a) A Coil with  $R= 10$  ohm and  $L =0.2$  H is in series with a capacitor of 20 micro Farad. Determine the Resonant Frequency, Q-factor and Band width.
- b) A series RC circuit having variable R and  $C=20$   $\mu$ f is supplied from AC source having voltage  $V=200$  Volt at  $\omega=2000$  rad/sec. Draw current locus for sample values of  $R=0,5, 15, 25, 35, 50$ .
- c) Determine the resonant frequency of the circuit shown below Figure

# DADI INSTITUTE OF ENGINEERING & TECHNOLOGY

(Approved by A.I.C.T.E., New Delhi & Affiliated to JNTU, Kakinada)



NAAC Accredited Institute

An ISO 9001:2008; ISO 14001:2004 & OHSAS 18001:2007 Certified Institution

NH-5, Anakapalle – 531002, Visakhapatnam, A.P.

Phone: 08924-221111 / 221122/9963981111, e-mail: [info@diet.edu.in](mailto:info@diet.edu.in)

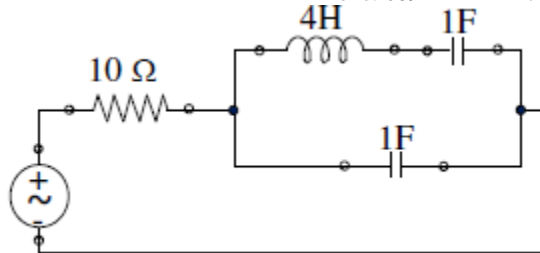

- 2.(a) Show that average power consumed by a pure inductor and a pure capacitor is zero.  
(b) A coil of inductance  $L$  and resistance  $R$  in series with a capacitor is supplied at a constant voltage from a variable frequency source. If the frequency is  $\omega$ , find in terms of  $L$ ,  $R$  and  $\omega$  the values of those frequencies at which the circuit current would be half as much as that at resonance. Hence or otherwise determine the bandwidth and selectivity of the circuit  
(c) Why the net voltage across  $L$  and  $C$  in a series  $R$ - $L$ - $C$  series circuit under resonance is zero
- 3.(a) A series RLC circuit with  $R=100\Omega$ ,  $L = 0.5H$ ,  $C=40\mu F$  has an applied voltage of  $100\angle 0^\circ$  with variable frequency. Calculate the resonance frequency, current at resonance and voltage across  $R$ ,  $L$ , and  $C$ . Also calculate the  $Q$ -factor, upper and lower cutoff frequencies  
(b) Why the current in AC series  $R$ - $L$ - $C$  circuit at resonance is maximum
4.  
(a) Define resonance and bandwidth  
(b) A Coil with  $R= 10 \text{ ohm}$  and  $L =0.2 \text{ H}$  is in series with a capacitor of  $20 \text{ micro Farad}$ . Determine the Resonant Frequency,  $Q$ -factor and Band width
- 5 An RLC series circuit with a resistance of  $10 \Omega$ , inductance of  $0.2H$  and a capacitance of  $40 \mu F$  is applied with a  $100 \text{ V}$  supply at variable frequency. Find the following with respect to the series resonant circuit  
(a) Frequency at which resonance takes place  
(b) Current  
(c) Power  
(d) Power factor  
(e) Quality factor  
(f) Half power frequencies
- 6(a) A coil of  $20 \text{ ohm}$  resistance and  $0.2 \text{ H}$  inductance is connected in parallel with capacitor of  $100 \mu F$  capacitance Find the frequency of resonance and the effective impedance at resonance.  
(b) Draw the current locus for a series RL circuit.  
(c) Determine the current supplied by the source at resonance for the circuit shown in Figure

# DADI INSTITUTE OF ENGINEERING & TECHNOLOGY



(Approved by A.I.C.T.E., New Delhi & Affiliated to JNTU, Kakinada)

NAAC Accredited Institute

An ISO 9001:2008; ISO 14001:2004 & OHSAS 18001:2007 Certified Institution

NH-5, Anakapalle – 531002, Visakhapatnam, A.P.

Phone: 08924-221111 / 221122/9963981111, e-mail: [info@diet.edu.in](mailto:info@diet.edu.in)

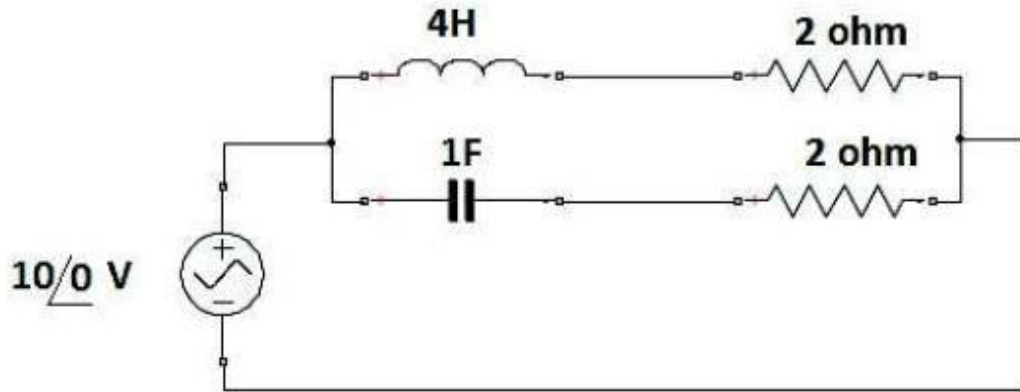

## UNIT-6

1(a) Find  $I$  in the circuit shown Figure 3, using superposition theorem

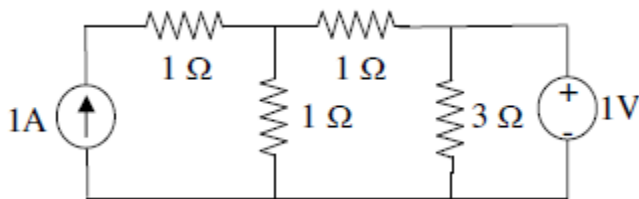

(b) Find the Thevenin equivalent circuit for the circuit shown below Figure

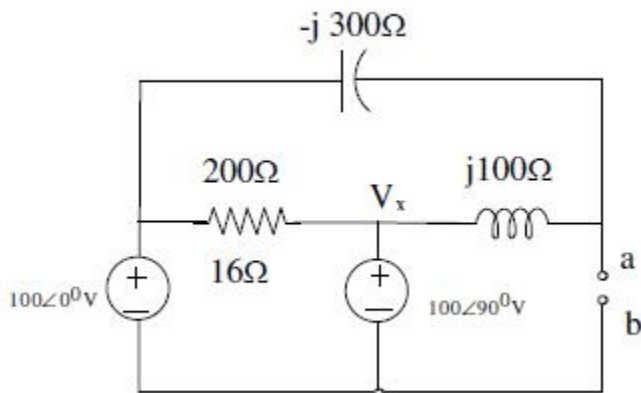

(c) State the maximum power transfer theorem.

# DADI INSTITUTE OF ENGINEERING & TECHNOLOGY

(Approved by A.I.C.T.E., New Delhi & Affiliated to JNTU, Kakinada)



**NAAC Accredited Institute**

An ISO 9001:2008; ISO 14001:2004 & OHSAS 18001:2007 Certified Institution

NH-5, Anakapalle – 531002, Visakhapatnam, A.P.

Phone: 08924-221111 / 221122/9963981111, e-mail: [info@diet.edu.in](mailto:info@diet.edu.in)

2(a) State and explain Norton's theorem

(b) State and explain compensation theorem

(c) For the network shown in figure:3, find the value of  $R_L$  for maximum power transfer. Also find the maximum power transferred to  $R_L$ .

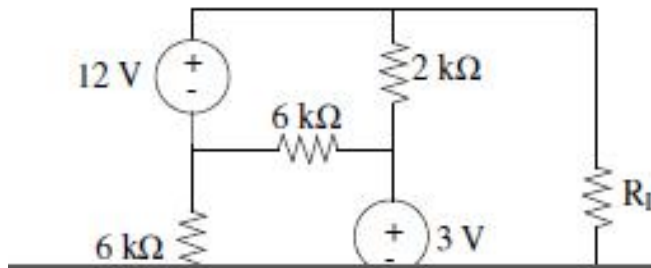

3(a) State and prove the superposition theorem with the help of an example.

(b) State Millman's theorem.

(c) State and explain Thevenin's theorem.

(d) For the network shown in figure:3, find the current through 1.375 ohms resistor and hence verify reciprocity theorem

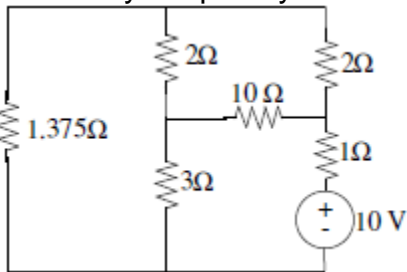

figure:3

4. (a) Use the superposition theorem to find  $v$  in the circuit of below Figure 4.

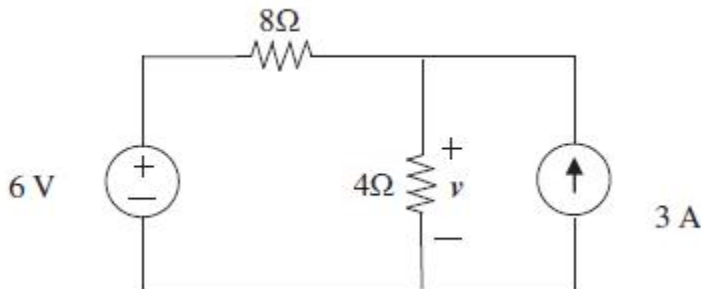

figure:4

(b) Using Norton's theorem, find  $R_N$  and  $I_N$  of the circuit in Figure at terminals a-b.

# DADI INSTITUTE OF ENGINEERING & TECHNOLOGY

(Approved by A.I.C.T.E., New Delhi & Affiliated to JNTU, Kakinada)



NAAC Accredited Institute

An ISO 9001:2008; ISO 14001:2004 & OHSAS 18001:2007 Certified Institution

NH-5, Anakapalle – 531002, Visakhapatnam, A.P.

Phone: 08924-221111 / 221122/9963981111, e-mail: [info@diet.edu.in](mailto:info@diet.edu.in)

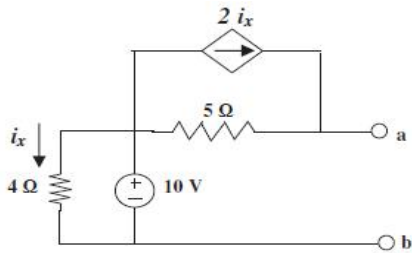

(c) Find the Thevenin's equivalent with respect to terminals a-b in the circuit shown in fig

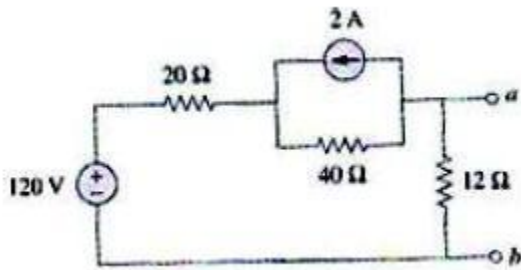

5(a) Find the current through 4ohm resistor in the Figure shown below using superposition theorem.

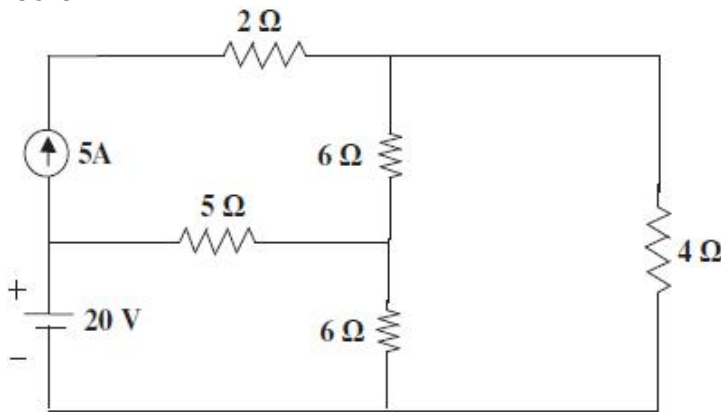

(b) Obtain Thevenin's equivalent network for the fi shown below

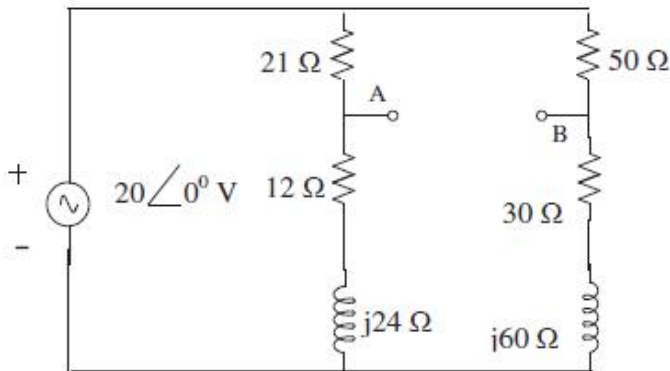





# DADI INSTITUTE OF ENGINEERING & TECHNOLOGY

(Approved by A.I.C.T.E., New Delhi & Affiliated to JNTUK, Kakinada)

**NAAC Accredited Institute**

An ISO 9001:2008, ISO 14001:2004 & OHSAS 18001:2007 Certified Institute.

**NH-5, Anakapalle – 531002, Visakhapatnam, A.P.**

**Phone: 08924-221111 / 221122/9963981111, www.diet.edu.in, E-mail: [info@diet.edu.in](mailto:info@diet.edu.in)**

---

---

## I B.Tech (Sem-II) QUESTION BANK

Branch : EEE/CIVIL Faculty : P.lakshmi narayana

### Sub: ENGINEERING DRAWING

---

---

#### UNIT-1

- 1.(a) construct a plain scale of RF 1:50000 TO show kilometers and hectometers and long enough to measure upto 7 kilometers. Measure a distance of 54 hectometers on your scale(7 M)
- (b) Draw an Octagon given the length of side 25mm (4M)
- 2.(a) construct a plain scale to show meters when 1 cm represents 4 meters and long enough to measure upto 50 meters . find the R.F and mark on your scale a distance of 36 meters(7M)
- (b) Construct a regular polygon of any number of sides, given the length of its sides equal to 25mm. (4M)
- 3.(a) The foci of an ellipse are 90mm apart and the minor axis is 72mm long. Determine the length of the major axis. Construct the ellipse. Draw a tangent to the ellipse from any point.(16M)
- (b) Construct a regular hexagon of side 28mm when one side is horizontal. (4M)
4. The major axis of an ellipse is 150mm long and the minor axis is 100mm long. Find the foci and draw the ellipse by arcs of circles method. Draw a tangent to the ellipse at a point on it 25mm above the major axis.(16M)
5. (a) Construct a DIAGONAL scale of RF 1:3200000 TO show kilometers and long enough to measure upto 400 km show distance of 257 KM AND 333 KM on your scale.(7M)
- (b) The foci of an ellipse are 90 mm apart and the minor axis is 72 mm long. Determine the length of the major axis. Construct the ellipse. (7M)
6. (a) Construct an ellipse when the major axis is 120 mm and the distance between the foci is 108 mm. Determine the length of the minor axis. (7M)
- (b) CONSTRUCT A vernier scale to read meters , decimeters and centimeters and long enough to measure upto 4 mt . RF of the scale is 1/20 MARK on your scale a distance of 2.28 mt(7M)

#### UNIT-II

- 1.(a) Draw the orthographic projections of the following points:
  - (i) A, 20mm above HP and 30mm behind VP
  - (ii) B, 25mm below HP and 25mm in front of VP
  - (iii) C, 25mm below HP and 30mm behind VP
  - (iv) D, 30mm below HP and in VP (7M)

- (b) The top view of a 75mm long line measures 55mm. The line is in the VP; its one end being 25mm above the HP. Draw its projections. (7M)
2. (a) A line MN 50mm long is parallel to VP and inclined at  $30^\circ$  to HP. The end M is 20mm above HP and 10mm in front of VP. Draw the projections of the line.(7M)
- (b) A point P is 20mm below HP and lies in the third quadrant. Its shortest distance from xy is 40mm. Draw its projections. (7M)
3. A line AB 50mm long is perpendicular to VP and parallel to HP. Its end A is 20mm in front of VP and the line is 40mm above HP. Draw the projections of the line.(16M)
- (i) A, 25mm above H.P and 35mm in front of V.P
- (ii) B, 25mm above H.P and 40 mm behind V.P
4. (a) The front view of a line inclined at  $30^\circ$  to the V.P is 65 mm long. Draw the projections of the line, when it is parallel to and 40 mm above the H.P, its one end being 30 mm in front of the V.P.(8M)
- (b) Mark the projections of the following points on a common reference line,(8M)
- (i) C, 30mm below H.P and 45 mm behind V.P
- (ii) D, 30 mm below H.P and 40 mm in front V.P
5. Two pegs fixed on a wall are 4.5 metres apart. The distance between the pegs measured parallel to the floor is 3.6 metres. If one peg is 1.5 m above the floor, find the height of the second peg and the inclination of the line joining the two pegs with the floor. (16M)
- 6.
- (a) A line PQ 40 mm long is parallel to VP and inclined at an angle of  $30^\circ$  to HP. The lower end P is 15 mm above HP and 20 mm in front of VP. Draw the projections of the line.(8M)
- (b) Draw the projections of a line EF 40 mm long parallel to HP and inclined at  $35^\circ$  to VP. E is 20 mm above HP and 15 mm in front of VP.(8M)

### UNIT-III

1. <sup>+</sup> The top view of a 75mm long line AB measures 65 mm, while the length of its front view is 50mm. Its one end A is in the HP AND 12 mm in front of the vp. draw the projections of AB and determine the inclinations with the HP AND the VP(16M)
2. A line CD measuring 80 mm is inclined at an angle of  $30^\circ$  to HP and  $45^\circ$  TO VP. the point C is 20 mm above HP and 30mm in front of VP. Draw the projections of the straight line(16M)
3. A line AB is 75mm long. A is 50 mm in front of VP and 15 mm above HP. B is 15mm in front of vp and is above HP. TOP VIEW OF AB is 50 mm long. Find the front view length and the true inclinations(16M)
4. A line AB 65 mm long has its end A 20 mm above HP AND 25mm in front of VP. END B is 40 mm above HP and 65mm in front of VP. Draw the projections of AB. find its inclinations with HP and VP(16M)
5. THE PROJECTIONS OF A line measure 80mm in the top view and 70mm in the front view. The MID-POINT of the line is 45mm in front of vp and 35mm above HP. ONE END IS 10 mm in front of VP and nearer to it. Draw the projections. find the true length and true inclinations with reference planes(16M)
6. A line AB 65 MM LONG HAS ITS END A .15 mm above HP AND 15MM IN FRONT OF VP. IT IS INCLINED AT  $55^\circ$  to HP and  $35^\circ$  to VP draw its projections(16M)

### UNIT-IV

1. A regular pentagonal plate of side 28mm is placed with one side on HP such that the surface is inclined at  $45^\circ$  to HP and perpendicular to VP. draw its projections and traces(16M)
2. A thin circular metal plate of 48 mm diameter, having its plane vertical and inclined at  $40^\circ$  to VP

- Its center is 33mm above HP and 25mm in front of VP. DRAW ITS projections and locate its traces(16M)
- 3 A thin rectangular plate of sides 50mm x 25mm has its shorter side in the HP and inclined at an angle of  $30^{\circ}$  to the VP. PROJECT ITS FRONT VIEW WHEN ITS TOP view is a perfect square of 25mm side(16M)
  - 4 A regular pentagonal lamina of 30mm sides has one edge in HP and inclined at an angle of  $30^{\circ}$  to VP DRAW ITS PROJECTIONS WHEN its surface is inclined at  $45^{\circ}$  to HP(16M)
  - 5 Draw the projections of the circle of 50 mm diameter resting in the H.P on a point A on the circumference, its plane inclined at  $45^{\circ}$  to the H.P and
    - (a) The top view of the diameter AB making  $30^{\circ}$  angle with the V.P(8M)
    - (b) The diameter AB making  $30^{\circ}$  angle with the V.P(8M)
  6. A circular lamina of 60mm diameter rests on Hp on a point 1 on the circumference. The lamina is inclined to HP such that the top view of it is an ellipse of minor axis 35mm. The top view of the diameter through the point 1 makes an angle of  $45^{\circ}$  with VP.(8M+8M)
    - i) Draw the projections
    - ii) Determine the angle made by the lamina with HP.

### UNIT-V(ALL QUESTIONS CARRY 16M)

1. Draw the projections of a cylinder, base 30mm diameter and axis 40mm long resting with a point of its base circle on HP such that the axis is making an angle of  $30^{\circ}$  with HP and parallel to VP.
2. A pentagonal prism side of base 25mm and axis 50mm long resting with one of its edges on HP such that the base containing that edge makes an angle of  $30^{\circ}$  to HP and its axis is parallel to VP. Draw its projections.
3. Draw the projections of a cylinder 75mm diameter and 100 mm long, lying on the ground with its axis inclined at  $30^{\circ}$  to the V.P and parallel to the ground.
4. Draw the projections of a cone, base 75 mm diameter and axis 100 mm long, lying on the H.P on one of its generators with the axis parallel to the V.P.
5. Draw the projections of a cone of base 30mm diameter and axis 50mm long resting on HP on a point of its base circle with the axis making an angle of  $45^{\circ}$  with HP and parallel to VP.
6. A cone 40mm base and axis 50mm long touches VP on a point of its base circle. The axis is inclined at  $30^{\circ}$  to VP and the front view of the axis is inclined at  $45^{\circ}$  to HP. Draw its projections?.

### UNIT-VI(ALL QUESTIONS CARRY 16M)

1. Draw the orthographic view as shown in fig

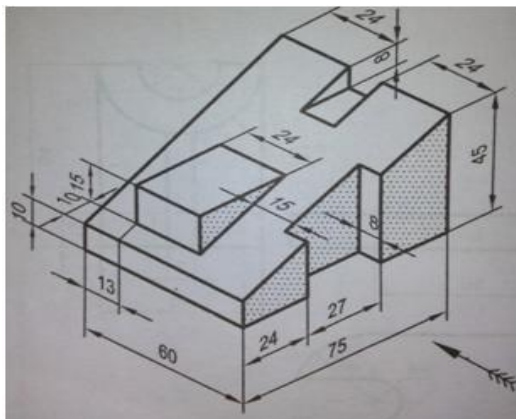

ALL DIMENSIONS ARE IN MM

2 Draw the orthographic view as shown in fig

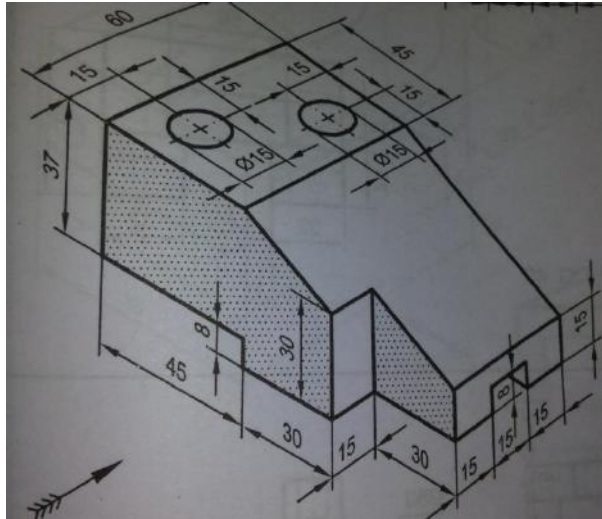

3 Draw the orthographic view as shown in fig

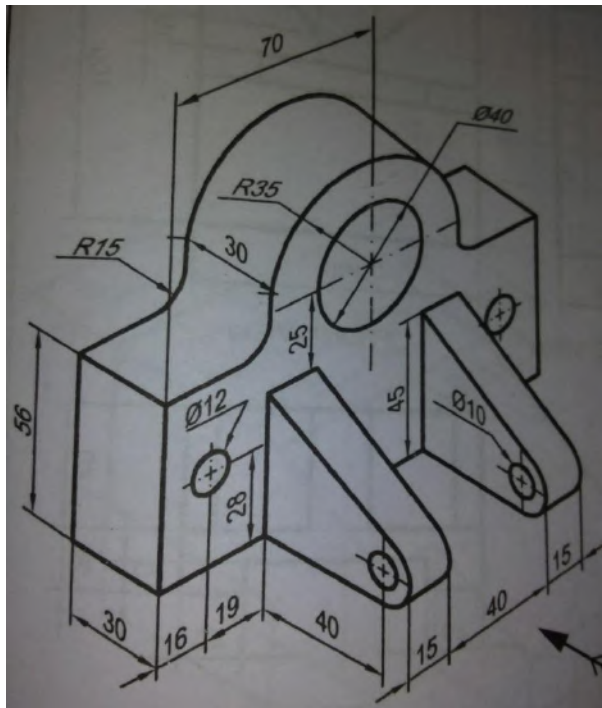

4 Draw the orthographic view as shown in fig

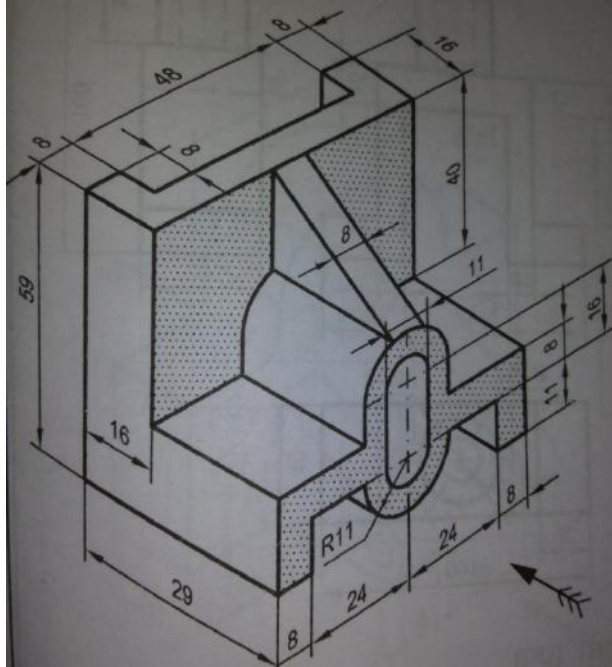

2. Draw (i) Front View (ii) Side View (iii) Top View as shown in fig

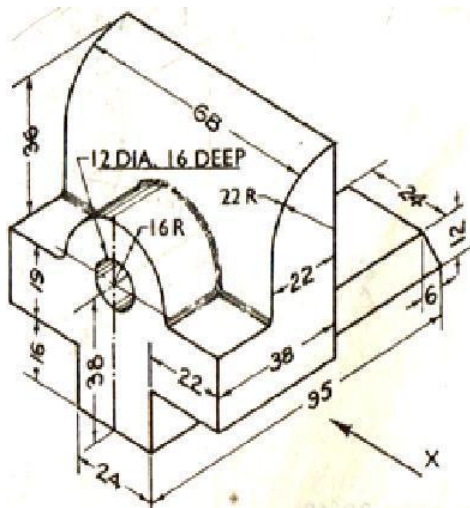

(Note: all dimensions are in mm)

3. Draw (i) Front View (ii) Top View (iii) Side View as shown in fig



(Note: all dimensions are in mm)

4. Draw the isometric view as shown in fig

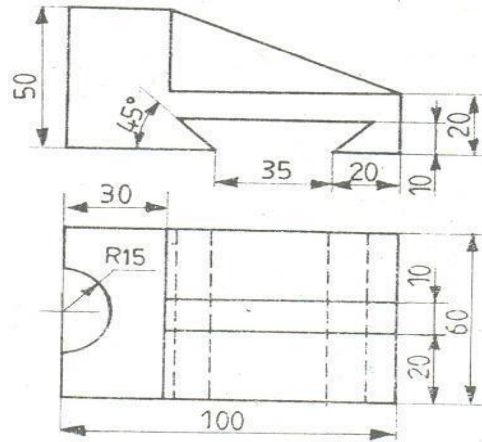

(Note: all dimensions are in mm)

5. Draw the isometric view as shown in fig

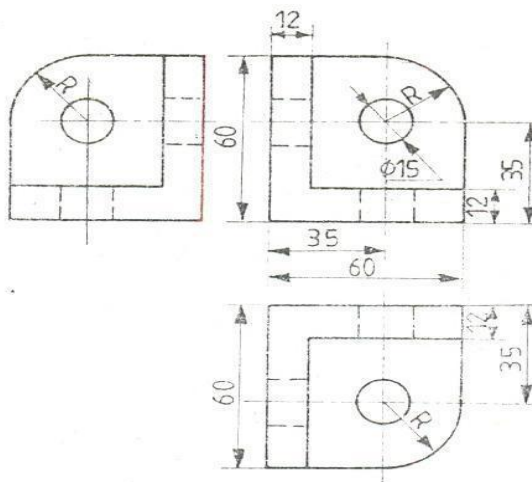

(Note: all dimensions are in mm)

6. Draw (i) Front View (ii) Top View (iii) Side View, as shown in fig.

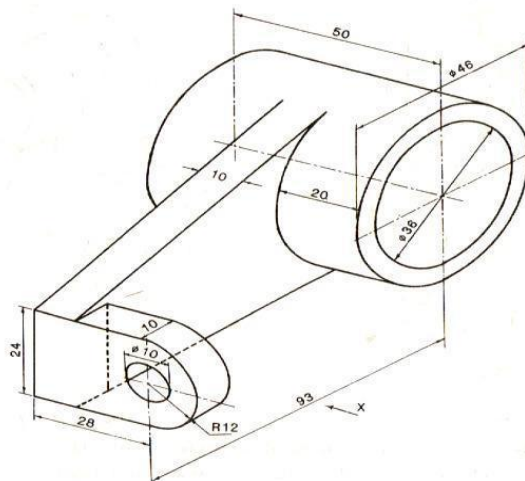



(Note: all dimensions are in mm)

7. Draw (i) Front View (ii) Side View from the right (iii) Top View as shown in fig

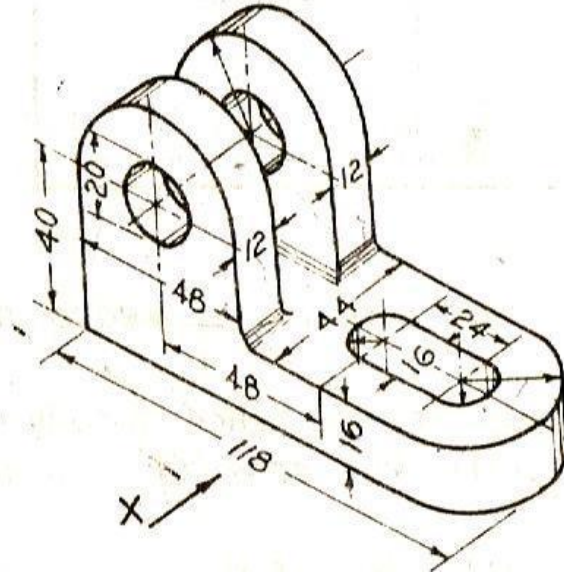

(Note: all dimensions are in mm)

8. Draw the isometric view as shown in fig.

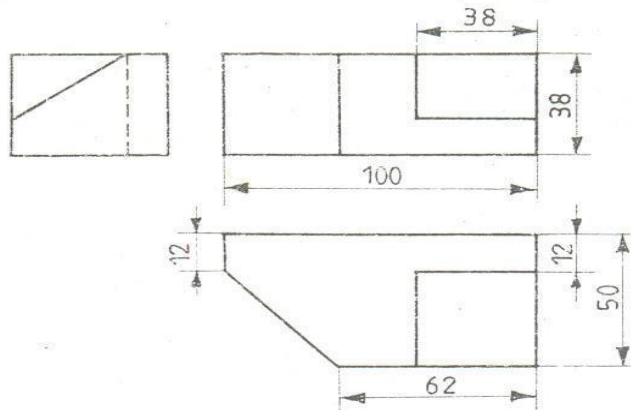

(Note: all dimensions are in mm)



# DADI INSTITUTE OF ENGINEERING & TECHNOLOGY

(Approved by A.I.C.T.E., New Delhi & Affiliated to JNTUK, Kakinada)

NAAC Accredited Institute

An ISO 9001:2008, ISO 14001:2004 & OHSAS 18001:2007 Certified Institute.

NH-5, Anakapalle – 531002, Visakhapatnam, A.P.

Phone: 08924-221111 / 221122/9963981111, www.diet.edu.in, E-mail: [info@diet.edu.in](mailto:info@diet.edu.in)

---

## I B.TECH - II SEM Question Bank

Subject Name: ENGG. PHYSICS

Branch: CIVIL, EEE

Faculty: Mr.APPARAO.P

---

### UNIT-1

- State and explain the Principle of superposition of waves. - 4M
  - Explain the formation of Newton's rings and obtain an expression for the diameter of the dark rings in reflected system. – 6M
- In Newton's rings experiment, diameter of the tenth dark ring due to wavelength  $6000\text{\AA}$  in air is 0.5 cm. Find the radius of curvature of the lens. – 4 M
  - If the air film in the Newton's rings apparatus is replaced by an oil film, then how does the radius of the rings change? Explain. – 6M
- What are the necessary conditions to get clear and distinct interference fringes – 4M
  - Describe principle ,construction and working of Michelson Interferometer. - 6M
- Explain the colours in a thin film when exposed it to a sun light – 4M
  - Explain why the centre of Newton's rings is dark in the reflected system. Why are they circular? 6M
- Distinguish between Monochromatic and Polychromatic light sources, Give one example for each
  - With a ray of diagram, discuss the theory of thin films and the condition constructive and destructive interference in the case of reflected light.—7M
- Describe principle ,construction and working of Febry-Perot Interferometer. - 6M
  - In Newton's rings experiment, diameter of  $10^{\text{th}}$  dark ring due to wavelength  $6000\text{ \AA}$  in air is 0.5 cm. Find the radius of curvature of lense.

### UNIT—II

- What are the types of diffraction and give the difference between them ? 4 M
  - Obtain the condition for primary maxima in Fraunhofer diffraction due to single slit and derive an expression for width of the central maxima - 6 M
- What is the difference between interference and diffraction –4M
  - Explain the diffraction due to two parallel slits and obtain the Intensity of light on the screen.—6M



3. a) Define the grating and Explain with necessary theory, the Fraunhofer diffraction due to 'N' parallel slits.- 6 M  
 b) Calculate the maximum number of order possible for a transmission grating - 4 M
4. a) What happens to the diffraction fringes, if the slit width is reduced in single slit experiment? Explain why?.- 6 M  
 b) A grating has 6000 lines/cm.Find the angular separation between two wavelengths of 500 nm and 510 nm in 3<sup>rd</sup> order – 4M
5. a) What is meant by Diffraction of light? Explain it on the basis of Huygen's wave theory ? 4 M  
 b) Explain the theory of plane transmission grating and derive equations for maxima and minima.- 6M
6. a) Define resolving power of grating and explain Rayleigh criterion for resolution and determine the resolving power of the Telescope - 6 M  
 b) How many orders will be visible ,if wave length of light is 5000 Å ? Given that the number of lines per centimeter on the grating is 6655. - 4 M

### UNIT – III

1. a) What is a half wave plate and Quarter wave plate? Deduce an expression for its thickness-6 M  
 b) Calculate the thickness of half wave plate of quartz for a wavelength 500nm. Here  $\mu_e = 1.553$  and  $\mu_o = 1.544$ . - 4 M
2. a) Distinguish between polarized and unpolarized lights –3M  
 b) State and explain Brewster's law? Discuss how the plane, Circular and Elliptical
3. a) Write a note on double refraction? 4M  
 b) Explain the principle, construction and working of a Nicol prism.-6M
4. a) Write the difference between Spontaneous and Stimulated Emissions.– 4M  
 b) Explain the working of Ruby laser with the help of neat energy level diagram..– 6M
5. a) What is population inversion and how can it be achieved ?.- 4 M  
 b) Explain the working of He-Ne gas laser with the help of neat energy level diagram.- 6 M
6. a) Explain Einstein's coefficients. Derive the relation between them.-5M  
 b) What are the characteristics and applications of LASER beam.-5M

## UNIT – IV

1. a) What is an electrical potential. Derive the electrical potential in an non-uniform electric field - 6M  
b) Write the Maxwell's electromagnetic equations in differential or integral form.– 4M
2. a) State and explain stokes and Gauss divergence theorems – 4 M  
b) Derive velocity of electromagnetic wave in a dielectric medium.– 6M
3. a) State and prove Gauss's divergence theorem and explain its importance.- 6 M  
b) What is divergence? Show that divergence of a vector field is a scalar ?– 4 M
4. a) What is a gradient? Show that gradient of a scalar is a vector- 4 M  
b) State and prove stokes theorem? Explain its importance -6 M
5. a) Define scalar field? Explain with examples - 3 M  
b) Derive wave equation for an electric field in dielectric medium.- 7 M
6. a) Define vector field? Explain with examples - 3 M  
b) Derive wave equation for a magnetic field in dielectric medium.- 7 M

## UNIT—V

1. a) Derive time independent wave equation for a free particle – 5 M  
b) Derive time dependent Schrodinger's wave equation for a free particle.– 5M
2. a) Derive Eigen values and Eigen functions for a particle in a one dimensional potential box.-7 M  
b) Calculate the minimum energy of free electron trapped in a one dimensional box of width 0.3 nm (given  $h = 6.63 \times 10^{-34}$  J. S and  $m_e = 9.1 \times 10^{-31}$  Kg).– 3M
3. a) What is Fermi level and explain the Fermi-Dirac distribution function of electron in ametal. .- 4 M  
b) Discuss the variation with temperature on the Fermi-Dirac distribution - 6 M
4. a) What are the properties of Matter waves?.- 4 M  
b) Distinguish between Lorentz-Drude theory and Sommerfeld theory of metals – 6 M
5. a) What is the most probable position for a particle in 1D potential box of width L in the first quantum state, explain graphically. How matter waves are different from Electromagnetic waves?.- 7 M

- b) If  $E$  is the ground state of the particle confined to move in a 3D potential box, what would be the increase in the energy from second energy to next higher energy level– 3M
6. a) Based on Sommerfeld quantum free electron theory, derive an expression for electrical conductivity in metals.- 6 M
- b) Explain the salient features & draw backs of Classical free electron theory..- 4 M

## UNIT- VI

1. a) What is Bloch theorem. Explain.- 3 M
- b) Explain the Kronig-penny model of solids and show that it leads to energy band structure.- 7 M
2. a) Explain the concept of effective mass of an electron..- 3 M
- b) What do you understand by drift and diffusion currents in the case of a semiconductor? Deduce Einstein's relation relating to these currents..– 7 M
3. a) Explain P- type extrinsic semiconductors.- 4 M
- b) Derive an expression for Fermi energy in extrinsic P-type semiconductor - 6 M
4. a) State and explain Hall Effect – 5 M
- b) Derive an expression for Hall coefficient and Give any two of its applications..- 5M
5. a) Distinguish between Intrinsic and Extrinsic semiconductors - 2M
- b) Derive the expression for concentration carriers in intrinsic semiconductor.– 8M
6. a) Distinguish between N- type and P- type extrinsic semiconductors – 4 M
- b) Derive the expression for Fermi energy in N-type extrinsic semiconductor..– 6M



# DADI INSTITUTE OF ENGINEERING & TECHNOLOGY

(Approved by A.I.C.T.E., New Delhi & Affiliated to JNTUK, Kakinada)

NAAC Accredited Institute

An ISO 9001:2008, ISO 14001:2004 & OHSAS 18001:2007 Certified Institute.

NH-5, Anakapalle – 531002, Visakhapatnam, A.P.

Phone: 08924-221111 / 221122/9963981111, www.diet.edu.in, E-mail: [info@diet.edu.in](mailto:info@diet.edu.in)

## Department of Basic Sciences & Humanities

SUBJECT: MATHEMATICAL METHODS

YEAR /SEM : I/II

FACULTY: B.CH.K.PREETHI, Asst. Prof.

BRANCHS: CIVIL & EEE

### UNIT-I

1. a) Find the Real root of the equation  $x^2 - x - 4 = 0$  using iteration method (5M)
- b) Find the Real root of the equation  $x^4 - x - 10 = 0$  using Newton Raphson method (5M)
- 2 (a) Using Newton-Raphson method find the root of the equation  $x + \log_{10} x = 3.375$  correct to four decimal places. (5M)
- b) Find the Real root of the equation  $e^x - 4x^2 = 0$  using Bisection method. (5M)
- 3 (a) Find the Real root of the equation  $x + \log_{10} x - 2 = 0$  using false position method (5M)
- (b) Solve  $x^3 - 2x - 5 = 0$ , for a positive root by iteration method. (5M)
- 4 (a) Using Newton – Raphson method, find a root of the equation  $2x - 3\sin x = 5$  near  $x=3$  correct to three decimal places. (5M)
- (b) Develop an Iterative formula to find  $\frac{1}{N}$  using Newton Raphson method (5M)
- 5(a) Using Regula-Falsi method, find the root of  $x^3 - x - 2 = 0$ , over (1, 2) (5M)
- (b) By using Newton-Raphson method, find the root of  $x^4 - x - 10 = 0$ , correct to three decimal places. (5M)
- 6(a) Solve the system of equations by Newton Raphson method  $3yx^2 - 10x + 7 = 0$  and  $y^2 - 5y + 4 = 0$  (5M)
- (b) Solve the system of equations by Newton Raphson method  $x^2 + y^2 - 1 = 0$  and  $y - x^2 = 0$  (5M)

## UNIT-II

1(a) Using Lagrange's interpolation formulae find the value of y (12) from the data (5M)

x	5	7	9	13
y	11	13	18	27

(b) Determine the value of f(x) at x = 25 for the following data (5M)

x	20	24	28	32
f(x)	24	32	35	40

2 (a) Find f(142) using Newton's forward formula for the following table

x	140	150	160	170	180	(5M)
Y=f(x)	3.685	4.854	6.302	8.076	10.225	

(b) Calculate f(3) from the following table. (5M)

X	0	1	2	4	5	6
f(x)	1	14	15	5	6	19

3(a) Given that f(6500) = 80.6223, f(6510) = 80.6846, f(6520) = 80.7456, f(6530) = 80.8084, Find f(6526) using Gauss backward interpolation formula. (5M)

(b) Using gauss forward difference formula, find y(12) from the given table (5M)

x	1	6	11	16	21	26
y	5	10	14	18	24	32

4 (a) Using Gauss Backward difference polynomial, find y(5) given that (5M)

X	2	4	6	8	10
Y	5	11	13	15	17

(b) Use Gauss backward interpolation formula to find f(32) given that f(25) = 0.2707, f(30) = 0.3027, f(35) = 0.3386, f(40) = 0.3794. (5M)

5(a) Prove that  $(1 + \Delta)(1 - \nabla) = 1$ . (3M)

(b) Compute f(27) using Lagranges formula from the following table

X	14	17	31	35
F(x)	68.7	64	44	39.1

(6M)

6(a) Prove that (i)  $\mu^2 = 1 + \frac{\delta^2}{4}$  (ii)  $\delta = E^{\frac{1}{2}} - E^{-\frac{1}{2}}$ . (6M)

(b) If the interval of differencing is unity, find  $\Delta^2 \sin(px + q)$ . (4M)

## UNIT-III

1(a) Using modified Euler method solve numerically the equation  $\frac{dy}{dx} = 2 + \sqrt{xy}$ , with  $y(1)=1$  to find  $y(1.2)$ . (5M)

(b) Using Euler's method, solve for  $y(0.6)$  from  $\frac{dy}{dx} = -2xy$ ,  $y(0) = 1$  using step size 0.2. (5M)

2(a) Given  $\frac{dy}{dx} = x + \sin y$ ,  $y(0) = 1$ , compute  $y(0.2)$  and  $y(0.4)$  using Euler's modified method. (5M) (b) A curve is observed to pass through the points given in the following table 5M

x	1.0	1.5	2.0	2.5	3.0	3.5	4.0
y	2	2.4	2.7	2.8	3	2.6	2.1

By using Simpson's rule find the area bounded by the curve and x axis between  $x=1$  and  $x=4$

3(a)  $y' = x^2 y + 1$ ,  $y(0) = 1$  using Taylor's method up to 3<sup>rd</sup> degree term and compute  $y(0.1)$

(5M)

(b) Solve  $y' = y - x^2$ ,  $y(0) = 1$  using Picard's method up to 4<sup>th</sup> approx.  $y(0.1)$  &  $y(0.2)$

(5M)

4(a) Evaluate  $\int_0^{0.6} e^{-x^2} dx$  by using Simpson's 1/3<sup>rd</sup> rule, taking seven ordinates. 5M

(b) Evaluate  $\int_0^{\pi} \frac{\cos x}{1+x} dx$  by (i) Trapezoidal rule (ii) Simpson's 3/8<sup>th</sup> Rule (5M)

5(a) Find  $y(0.1)$  using 4<sup>th</sup> order Runge-Kutta method given that  $y' = x + x^2 y$ ,  $y(0) = 1$ . (5M)

(b) Use Runge-Kutta 4<sup>th</sup> order to compute  $y(1.2)$  for the equation  $y' = \frac{x^2+y}{x}$ ,  $y(1) = 2$  (5M)

6. (a) Evaluate  $\int_0^6 \frac{dx}{1+x^2}$  by using Simpson's 3/8<sup>th</sup> rule 5M

(b) Evaluate  $\int_0^1 \frac{dx}{1+x}$  by using Trapezoidal rule. 5M

## UNIT IV

1. (a) Obtain the Fourier series for  $f(x) = e^x$  in the interval  $0 < x < 2\pi$ . 5M  
(b) Find a Fourier series to represent the function  $f(x) = x - x^2$  from  $x = -\pi$  to  $x = \pi$  5M

2. (a) Expand  $f(x) = x \sin x$  as a Fourier series in the interval  $-\pi < x < \pi$ . 5M

And show that 
$$\frac{1}{1.3} - \frac{1}{3.5} + \frac{1}{5.7} - \frac{1}{7.9} \dots = \frac{\pi-2}{4}$$

- (b) Find the Fourier series of  $f(x) = \begin{cases} 0, & -\pi < x < 0 \\ \frac{\pi}{4}, & 0 < x < \pi \end{cases}$  5M

3. (a) Obtain the Fourier series to represent  $f(x) = \frac{1}{4}(\pi - x^2)$ ,  $0 < x < 2\pi$ . 5M

- (b) Find the Fourier series of the periodic function defined as  $f(x) = \begin{cases} -\pi, & -\pi < x < 0 \\ x, & 0 < x < \pi \end{cases}$

Hence, deduce that  $\frac{1}{1^2} + \frac{1}{3^2} + \frac{1}{5^2} + \dots = \frac{\pi^2}{8}$  5M

4. (a) Find Fourier cosine series of the function  $f(x) = \sin x$  in  $(0, \pi)$  and hence show that

$$\sum_{n=1}^{\infty} \frac{1}{4n^2-1} = \frac{1}{2} \quad 5M$$

- (b) Find the half range sine series of  $f(x) = \begin{cases} \frac{\pi}{2}, & 0 < x < \frac{\pi}{2} \\ \pi - x, & \frac{\pi}{2} < x < \pi \end{cases}$  5M

5. (a) Find the Fourier series of the function  $f(x) = \begin{cases} 0, & 0 < x < 1 \\ x^2, & 1 < x < 2 \end{cases}$  5M

- (b) Find Fourier cosine series for  $f(x) = x(x-2)$ , in  $0 \leq x \leq 2$  and hence find the sum of the series

$$\frac{1}{1^2} - \frac{1}{2^2} + \frac{1}{3^2} - \frac{1}{4^2} + \dots \quad 5M$$

6. (a) Find the Fourier series of periodicity 2 for  $f(x) = x + x^2$ , in  $0 < x < 2$  5M

- (b) Find the half range cosine series of  $f(x) = \begin{cases} 1, & 0 < x < \frac{\pi}{2} \\ -1, & \frac{\pi}{2} < x < \pi \end{cases}$  5M

## UNIT -V

1. (a) Using the method of separation of variables, solve  $\frac{\partial u}{\partial x} = 2\frac{\partial u}{\partial t} + u$  where  $u(x, 0) = 6e^{-3x}$ . 5M
- (b) Using the method of separation of variables, solve  $4\frac{\partial u}{\partial x} + \frac{\partial u}{\partial y} = 3u$ , given that  $u(0, y) = 3e^{-y} - e^{-5y}$  5M
2. A tightly stretched string with fixed end points  $x=0$  and  $x=l$  is initially in a position given by  $y = y_0 \sin^3\left(\frac{\pi x}{l}\right)$ . If it is released from this position, find the displacement  $y(x, t)$ . 10M
3. Solve the equation  $\frac{\partial u}{\partial t} = \frac{\partial^2 u}{\partial x^2}$  with boundary conditions  $u(x, 0) = 3\sin(n\pi x)$ ,  $u(0, t) = 0$  and  $u(l, t) = 0$ , where  $0 < x < l, t > 0$ . 10M
4. Solve the laplace equation  $\frac{\partial^2 u}{\partial x^2} + \frac{\partial^2 u}{\partial y^2} = 0$  subject to the conditions  $u(0, y) = u(l, y) = u(x, 0) = 0$  and  $u(x, a) = \sin(n\pi x/l)$ . 10M
5. Solve by the method of separation of variables  $\frac{\partial u}{\partial x} = 4\frac{\partial u}{\partial y}$  and  $u(0, y) = 8e^{-3y}$  10M
6. Find the solution of the wave equation  $\frac{\partial^2 u}{\partial t^2} = a^2 \frac{\partial^2 u}{\partial x^2}$ , if the initial deflection is  $f(x) = \begin{cases} \frac{2k}{l}x, & \text{if } 0 < x < \frac{l}{2} \\ \frac{2k}{l}(l-x), & \text{if } \frac{l}{2} < x < l \end{cases}$  and initial velocity equal to 0. 10M

## UNIT VI

1. (a) Using Fourier integral, Show that  $\int_0^\infty \frac{\cos \lambda x}{\lambda^2 + a^2} d\tau = \frac{\pi}{2a} e^{-ax}$ ,  $a > 0, x \geq 0$ . 5M
- (b) Find the Fourier transform of  $f(x) = \begin{cases} x, & \text{if } |x| \leq 1 \\ 0, & \text{if } |x| > 1 \end{cases}$  5M
2. (a) Find the Fourier transform of  $\frac{1}{\sqrt{|x|}}$  5M
- (b) Find the Fourier sine transform of  $e^{-|x|}$ . 5M
3. (a) If  $F(p)$  or  $F(s)$  is the complex Fourier transform of  $f(x)$  then the complex Fourier transform of  $f(x) = \cos ax$  Then find the complex Fourier transform of  $f(x) = \cos ax$  5M
- (b) Find the Fourier sine and cosine transforms of  $2e^{-5x} + 5e^{-2x}$  5M



4. (a) Find the Fourier sine transform of  $f(x) = e^{-ax}$ ,  $a > 0$  and deduce the inversion formula. 5M  
(b) Find the inverse Fourier sine transform of  $f(x)$  of  $F_s(p) = \frac{p}{1+p^2}$ . 5M
5. (a) Find the Fourier Cosine transform of  $\frac{e^{-ax}}{x}$  5M  
(b) Find the inverse Fourier sine transform  $f(x)$  of  $F_s(p) = \frac{e^{-ap}}{p}$ ; and show that  $F_s^{-1}(1/p) = 1$ . 5M
6. (a) Prove that  $F[x^n f(x)] = (-i)^n \frac{d^n}{dp^n} [F(p)]$ . 5M  
(b) Prove that  $F\left[\frac{d^n}{dx^n} f(x)\right] = (-ip)^n F(p)$ . where  $F[f(x)] = F(p)$ . 5M



# DADI INSTITUTE OF ENGINEERING & TECHNOLOGY

(Approved by A.I.C.T.E., New Delhi & Affiliated to JNTUK, Kakinada)

**NAAC Accredited Institute**

An ISO 9001:2008, ISO 14001:2004 & OHSAS 18001:2007 Certified Institute.

**NH-5, Anakapalle – 531002, Visakhapatnam, A.P.**

Phone: 08924-221111 / 221122/9963981111, www.diet.edu.in, E-mail: [info@diet.edu.in](mailto:info@diet.edu.in)

---

## I B.TECH Question Bank

**Subject : ENGLISH-II    Branch: EEE, CIVIL.**

**Faculty: MS. S.VANAJA**

---

### **Unit-I**

**1.A. Why does the author say that the Know how produced by Science and technology is an unfinished sentence?**

**1. B. What is hovercraft?**

**1. C. Give synonyms for the following-1. Strengthen, 2. Resource.**

**2. A. Explain Schumacher views on education?**

**2. B. What was the objective of the SLV project?**

**2. C. Give the synonyms of the following**

**1. Precipitate**

**2. Antecedent**

**3. A. What are the arguments which the author put forward to show that education is necessary?**

**3. B. Who helped Kalam design the guidance systems for Agni Missile?**

**3. C. Give synonyms for following-**

**1. Apprehension**

**2. Brink**

**4. A. What should be done to overcome the problems of modern life?**

**4. B. Why Abdul Kalam is called the Missile Man of India?**

**4. C. Give Antonyms for the following words-**

**1. Decline**

**2. Civilized**

**5. A Write a letter to the editor of a leading newspaper on the problem of eve - teasing in your city.**

**5. B. Explain the work Kalam did at DRDO.**

**5. C. Give Antonyms for the following words**

**1. Inferior**

**2. Conceal**

**6. A. How is positive attitude helpful for the students?**

**6. B .Name a few awards that Kalam won.**

**6. C. Give antonyms for the following words-**

**1. Culminate**

**2. Persuade**

## **UNIT-II**

**1. A Describe any modern invention with its positive and negative effects on the society.**

**1. B. At what age did Raman join the graduation class? Can you remember an interesting anecdote concerning his English teacher?**

**1.C. Write the superlative adjectives for the following words**

**i. Beautiful                      ii. Sweet**

**2. A. Who is responsible for the destructive use of scientific inventions – science or people?**

**2.B. What were some of the changes that Raman had initiated at the Indian Institute of Science?**

**2. C. Write the superlative adjectives for the following words**

- i. Tall
- ii. Bright

**3. A. What, according to the author, is the first reaction of a layman to the bomb on Hiroshima?**

**3.B Where did Raman do his M. A. from? What was his subject?**

**3. C. Write superlative adjectives for the following words:**

- i. Clever
- ii. Hard

**4. A. What are views of author on science and its repercussions?**

**4. B. Why did Raman resign from his job after 10 year of service? Why did he take a cut in his salary?**

**4. C. Fill in the blanks with appropriate words**

1. SLV stands for

2. Kalam's first school was

**5. A. You are Mr. Deepak, the librarian of KV AFA. Write an email to Rana book depot, Hyderabad requesting them to cancel your order for English literary books and Children's story book. Give reasons for cancellation of the order.**

**5. B. Explain the Raman Effect.**

**5. C. Write synonyms for the following words:**

- i. Mooting
- ii. Distinguished

**6. A. Explain the importance of Self-Management.**

**6. B. Describe the work that got Raman a Noble Prize.**

**6. C. Write the adjective form for the following words:**

- i. Hunger
- ii. Health

**1.A. What is Cultural Shock? Explain.**

**1. B. What were the objectives Bhabha wanted to fulfill with the nuclear Programme?**

**1. C. Fill in the blank with an appropriate form of the verb given in brackets**

**1. The deaf and the blind --- (find) it was very difficult to acquire the amenities of conversation.**

**2. She --- (like) coffee compared to tea.**

**2. A. How does the author define 'culture shock'? What are the symptoms according to him?**

**2. B. What was the most devastating event during the World War II?**

**2. C. Fill in each blank with an appropriate form of the verb given in brackets**

**1. When he --- (come) home I was taking shower.**

**2. He --- (finish) homework before I called him.**

**3. A. Write the four stages of cultural shock.**

**3. B. Note contributions of Ernest Rutherford.**

**3. C. Fill in the blank with an appropriate form of the verb given in brackets**

**1. The train --- (have left) before I reached the station.**

**2. She --- (lost) the key just now.**

**4. A. Prepare a 5 minutes speech expressing your views on the following topic: *Betting in sports.***

**4. B. Who was Dirac? What was his major contribution?**

**4. C. Fill in the blank with an appropriate form of the verb given in brackets**

**1. She --- (play) football every day.**

**2. She --- (go) to church every Sunday.**

**5.. A. Explain Non - Verbal Communication.**

**5. B. What were Bhabha's efforts to set up research institute in India?**

**5. C. Fill in the blank with an appropriate form of the verb given in brackets**

**She --- (see) Delhi many times.**

**She --- (have work) a lawyer since 2000.**

**6.A. What is Body Language?**

**6.B. What is the message of Bhaba to the youth?**

**6.C. Fill in the blank with an appropriate form of the verb given in brackets**

**1. Summer-----(come) after winter.**

**2. She----- (meet) the principal yesterday.**

## **English –II SEM-II MID II -QUESTION BANK-R16 REGULATIONS**

### **UNIT-IV**

**I 1. What seems to have been the original purpose of the lottery? What do people believe about it?-5M**

**2. What was Bose's attitude towards education as he grew up?-3M**

**3. In questions given below out of four alternatives, choose the one which can be substituted for the given word/sentence.-2M**

**a. That which cannot be corrected**

**A). Unintelligible B). Indelible C). Illegible D). Incurable**

**b. The study of ancient societies**

**A). Anthropology B). Archaeology C). History D). Ethnology**

**II 1. Is it important that the original paraphernalia for the lottery had been lost? What do you suppose the original ceremony was like? Why have some of the villages given up this practice? Why hasn't this one?-5M**

**2. Why did Bose shift his interest? What were his contributions to the two fields he worked in?-3M**

**3. In questions given below out of four alternatives, choose the one which can be substituted for the given word/sentence.-2M**

**A.A person of good understanding knowledge and reasoning power**

A). Expert B). Intellectual C). Snob D). Literate

B. A person who insists on something

A). Disciplinarian B). Stickler C). Instantaneous D). Boaster

**III 1. Is the lottery a collective act of murder? Is it morally justified? Is tradition sufficient justification for such actions? How would you respond to cultures that are different from ours that perform "strange" rituals?-5M**

**2. Give an account of Bose's experiments relating to plant responses.-3M**

**3. In questions given below out of four alternatives, choose the one which can be substituted for the given word/sentence.-2M**

a. State in which the few govern the many

A). Monarchy B). Oligarchy C). Plutocracy D). Autocracy

B. A style in which a writer makes a display of his knowledge

A). Pedantic B). Verbose C). Pompous D). Ornate

**IV. 1. Write an essay on- "Global Warming"-5M**

**2. Write the views of the author on J.C.Bose. -3M**

**3. In questions given below out of four alternatives, choose the one which can be substituted for the given word/sentence.-2M**

a. A person who knows many foreign languages

A). Linguist B). Grammarian C). Polyglot D). Bilingual

b. One who possesses many talents?

A). Versatile B). Nubile C). Exceptional D). Gifted

**V. 1. Write a newspaper report about an accident that took place on the main road in your town.-5M**

**2. Explain the childhood and early life of J.C.Bose.-3M**

**3. In questions given below out of four alternatives, choose the one which can be substituted for the given word/sentence.-2M**

a. One who eats everything

A). Omnivorous B). Omniscient C). Irascible D). Insolvent

b. The custom or practice of having more than one husband at same time

A). Polygyny B). Polyphony C). Polyandry D). Polychromic

## **UNIT- V**

**I.1.How does climate change affect human health?-5M**

**2. Explain the early life of Prafulla Chandra Ray.-3M**

**3. Fill the blank with suitable preposition.-2M**

a. Peter is playing tennis \_\_\_\_\_ Sunday.

b. What are you doing \_\_\_\_\_ the afternoon?

**II. 1. Write a short note on aeroallergens.-5M**

**2. What are the contributions and achievements of Prafulla Chandra Ray?-3M**

**3. Fill the blank with suitable preposition.-2M**

A. The shops open \_\_\_\_\_ nine.

B. She has never seen the sea \_\_\_\_\_ winter.

**III. 1.How can we prevent climate change?-5M**

**2. Explain Assertiveness.-3M**

**3. Fill the blank with suitable preposition.-2M**

A.I have been waiting for you \_\_\_\_\_ seven o'clock.



B.I will have finished this essay \_\_\_\_\_ Friday.

**IV. 1.How are morality and excessive heat related?-5M**

**2. Write an essay on – “Climate Change”.-3M**

**3. Fill the blank with suitable preposition.-2M**

- a. We are going to see my parents \_\_\_\_\_ the weekend.
- b. In 1666, a great fire broke out \_\_\_\_\_ London.

**V. 1. What is public health surveillance and why is it important?-5M**

**2. Write an article on- “Air Pollution”.-3M**

**3. Fill the blank with suitable preposition.-2M**

- a. My brother's birthday is \_\_\_\_\_ the 5th of November.
- b. My birthday is \_\_\_\_\_ May.

**UNIT- VI**

**I. 1.What does SMART mean in goal setting?-5M**

**2. Who is Paul Allen? Write the achievements of Allen with Gates.-3M**

**3. Fill the gap with the suitable verb.-2M**

A. One of my friends \_\_\_\_\_gone to France. (has / have)

B. Each of the boys \_\_\_\_\_ given a present. (was / were)

**II.1. Why IBM approached Bill Gates? Explain the problems and prospects of their agreement.-5M**

**2. Who is Srinivasa Ramanujan?-3M**

**3. Fill the gap with the suitable verb.-2M**

A. Neither of the contestants \_\_\_\_\_ able to win a decisive victory. (was / were)

B. Oil and water \_\_\_\_\_ not mix. (do / does)

**III.1. Explain the family details of Bill Gates.-5M**

**2. Explain the education and research career of Srinivasa Ramanujan?-3M**

**3. Fill the gap with the suitable verb.-2M**

a. He and I \_\_\_\_\_ at Oxford together. ( was / were)

b. Slow and steady \_\_\_\_\_ the race. (win / wins)

**IV. 1. What are the advantages of team work?-5M**

**2. Explain the achievements of Ramanujan at Cambridge.-3M**

**3. Fill the gap with the suitable verb.-2M**

A. Neither Peter nor James \_\_\_\_\_ any right to the property. (has / have)

B. No prize or medal \_\_\_\_\_ given to the boy, though he stood first in the examination. (was / were)

**V. 1. Why did Bill Gates and Allen sue a case against the new owner of MITS?-5M**

**2. Write a report on- “Blood donation camp”.-3M**

**3. Fill the gap with the suitable verb.-2M**

a. Either Mary or Alice ..... responsible for this. (is / are)

b. Neither the Minister nor his colleagues ..... given any explanation for this.  
(have / has)



## **DADI INSTITUTE OF ENGINEERING & TECHNOLOGY**

(Approved by A.I.C.T.E., New Delhi & Affiliated to JNTUK, Kakinada)

**NAAC Accredited Institute**

An ISO 9001:2008, 14001:2004 & OHSAS 18001:2007 Certified Institute

NH-5, Anakapalle, Visakhapatnam-531002, Andhra Pradesh

### **English –II QUESTION BANK – I/II B.TECH EEE**

#### **Unit-I**

**1.A. Why does the author say that the Know how produced by Science and technology is an unfinished sentence?**

**1. B. What is hovercraft?**

**1. C. Give synonyms for the following-1. Strengthen, 2. Resource.**

**2. A. Explain Schumacher views on education?**

**2. B. What was the objective of the SLV project?**

**2. C. Give the synonyms of the following**

**1. Precipitate**

**2. Antecedent**

**3. A. What are the arguments which the author put forward to show that education is necessary?**

**3. B. Who helped Kalam design the guidance systems for Agni Missile?**

**3. C. Give synonyms for following-**

**1. Apprehension**

**2. Brink**

**4. A. What should be done to overcome the problems of modern life?**

**4. B. Why Abdul Kalam is called the Missile Man of India?**

**4. C. Give Antonyms for the following words-**



## **DADI INSTITUTE OF ENGINEERING & TECHNOLOGY**

(Approved by A.I.C.T.E., New Delhi & Affiliated to JNTUK, Kakinada)

**NAAC Accredited Institute**

An ISO 9001:2008, 14001:2004 & OHSAS 18001:2007 Certified Institute  
NH-5, Anakapalle, Visakhapatnam-531002, Andhra Pradesh

**1. Decline**

**2. Civilized**

**5. A Write a letter to the editor of a leading newspaper on the problem of eve - teasing in your city.**

**5. B. Explain the work Kalam did at DRDO.**

**5. C. Give Antonyms for the following words**

**1. Inferior**

**2. Conceal**

**6. A. How is positive attitude helpful for the students?**

**6. B .Name a few awards that Kalam won.**

**6. C. Give antonyms for the following words-**

**1. Culminate**

**2. Persuade**

## **UNIT-II**

**1. A Describe any modern invention with its positive and negative effects on the society.**

**1. B. At what age did Raman join the graduation class? Can you remember an interesting anecdote concerning his English teacher?**

**1.C. Write the superlative adjectives for the following words**



## **DADI INSTITUTE OF ENGINEERING & TECHNOLOGY**

(Approved by A.I.C.T.E., New Delhi & Affiliated to JNTUK, Kakinada)

**NAAC Accredited Institute**

An ISO 9001:2008, 14001:2004 & OHSAS 18001:2007 Certified Institute

NH-5, Anakapalle, Visakhapatnam-531002, Andhra Pradesh

- i. Beautiful                      ii. Sweet

**2. A. Who is responsible for the destructive use of scientific inventions – science or people?**

**2.B. What were some of the changes that Raman had initiated at the Indian Institute of Science?**

**2. C. Write the superlative adjectives for the following words**

- i. Tall                              ii. Bright

**3. A. What, according to the author, is the first reaction of a layman to the bomb on Hiroshima?**

**3.B. Where did Raman do his M. A. from? What was his subject?**

**3. C. Write superlative adjectives for the following words:**

- i. Clever                              ii. Hard

**4. A. What are views of author on science and its repercussions?**

**4. B. Why did Raman resign from his job after 10 year of service? Why did he take a cut in his salary?**

**4. C. Fill in the blanks with appropriate words**

1. SLV stands for

2. Kalam's first school was

**5. A. You are Mr. Deepak, the librarian of KV AFA. Write an email to Rana book depot, Hyderabad requesting them to cancel your order for English literary books and Children's story book. Give reasons for cancellation of the order.**

**5. B. Explain the Raman Effect.**



## **DADI INSTITUTE OF ENGINEERING & TECHNOLOGY**

(Approved by A.I.C.T.E., New Delhi & Affiliated to JNTUK, Kakinada)

**NAAC Accredited Institute**

An ISO 9001:2008, 14001:2004 & OHSAS 18001:2007 Certified Institute  
NH-5, Anakapalle, Visakhapatnam-531002, Andhra Pradesh

### **5. C. Write synonyms for the following words:**

- i. Mooting
- ii. Distinguished

### **6. A. Explain the importance of Self-Management.**

#### **6. B. Describe the work that got Raman a Noble Prize.**

### **6. C. Write the adjective form for the following words:**

- i. Hunger
- ii. Health

## **Unit III**

### **1.A. What is Cultural Shock? Explain.**

#### **1. B. What were the objectives Bhabha wanted to fulfill with the nuclear Programme?**

#### **1. C. Fill in the blank with an appropriate form of the verb given in brackets**

**1. The deaf and the blind --- (find) it was very difficult to acquire the amenities of conversation.**

**2. She --- (like) coffee compared to tea.**

**2. A. How does the author define 'culture shock'? What are the symptoms according to him?**

**2. B. What was the most devastating event during the World War II?**

#### **2. C. Fill in each blank with an appropriate form of the verb given in brackets**

**1. When he --- (come) home I was taking shower.**



## DADI INSTITUTE OF ENGINEERING & TECHNOLOGY

(Approved by A.I.C.T.E., New Delhi & Affiliated to JNTUK, Kakinada)

**NAAC Accredited Institute**

An ISO 9001:2008, 14001:2004 & OHSAS 18001:2007 Certified Institute  
NH-5, Anakapalle, Visakhapatnam-531002, Andhra Pradesh

2. He --- (finish) homework before I called him.

**3. A. Write the four stages of cultural shock.**

**3. B. Note contributions of Ernest Rutherford.**

**3. C. Fill in the blank with an appropriate form of the verb given in brackets**

1. The train --- (have left) before I reached the station.

2. She --- (lost) the key just now.

**4. A. Prepare a 5 minutes speech expressing your views on the following topic: *Betting in sports.***

**4. B. Who was Dirac? What was his major contribution?**

**4. C. Fill in the blank with an appropriate form of the verb given in brackets**

1. She --- (play) football every day.

2. She --- (go) to church every Sunday.

**5.. A. Explain Non - Verbal Communication.**

**5. B. What were Bhabha's efforts to set up research institute in India?**

**5. C. Fill in the blank with an appropriate form of the verb given in brackets**

She --- (see) Delhi many times.

She --- (have work) a lawyer since 2000.

**6.A. What is Body Language?**

**6.B. What is the message of Bhabha to the youth?**

**6.C. Fill in the blank with an appropriate form of the verb given in brackets**

**1. Summer----- (come) after winter.**



## **DADI INSTITUTE OF ENGINEERING & TECHNOLOGY**

(Approved by A.I.C.T.E., New Delhi & Affiliated to JNTUK, Kakinada)

**NAAC Accredited Institute**

An ISO 9001:2008, 14001:2004 & OHSAS 18001:2007 Certified Institute

NH-5, Anakapalle, Visakhapatnam-531002, Andhra Pradesh

2. She----- (meet) the principal yesterday.

### **English –II SEM-II MID II -QUESTION BANK-R16 REGULATIONS**

#### **UNIT-IV**

**I 1. What seems to have been the original purpose of the lottery? What do people believe about it?-5M**

**2. What was Bose's attitude towards education as he grew up?-3M**

**3. In questions given below out of four alternatives, choose the one which can be substituted for the given word/sentence.-2M**

a. That which cannot be corrected

A). Unintelligible B). Indelible C). Illegible D). Incurable

b. The study of ancient societies

A). Anthropology B). Archaeology C). History D). Ethnology

**II 1. Is it important that the original paraphernalia for the lottery had been lost? What do you suppose the original ceremony was like? Why have some of the villages given up this practice? Why hasn't this one?-5M**

**2. Why did Bose shift his interest? What were his contributions to the two fields he worked in?-3M**

**3. In questions given below out of four alternatives, choose the one which can be substituted for the given word/sentence.-2M**

A.A person of good understanding knowledge and reasoning power





## **DADI INSTITUTE OF ENGINEERING & TECHNOLOGY**

(Approved by A.I.C.T.E., New Delhi & Affiliated to JNTUK, Kakinada)

**NAAC Accredited Institute**

An ISO 9001:2008, 14001:2004 & OHSAS 18001:2007 Certified Institute  
NH-5, Anakapalle, Visakhapatnam-531002, Andhra Pradesh

**A). Expert B). Intellectual C). Snob D). Literate**

B. A person who insists on something

**A). Disciplinarian B). Stickler C). Instantaneous D). Boaster**

**III 1. Is the lottery a collective act of murder? Is it morally justified? Is tradition sufficient justification for such actions? How would you respond to cultures that are different from ours that perform "strange" rituals? -5M**

**2. Give an account of Bose's experiments relating to plant responses. -3M**

**3. In questions given below out of four alternatives, choose the one which can be substituted for the given word/sentence. -2M**

a. State in which the few govern the many

**A). Monarchy B). Oligarchy C). Plutocracy D). Autocracy**

B. A style in which a writer makes a display of his knowledge

**A). Pedantic B). Verbose C). Pompous D). Ornate**

**IV. 1. Write an essay on- "Global Warming" -5M**

**2. Write the views of the author on J.C. Bose. -3M**

**3. In questions given below out of four alternatives, choose the one which can be substituted for the given word/sentence. -2M**

a. A person who knows many foreign languages

**A). Linguist B). Grammarian C). Polyglot D). Bilingual**



## **DADI INSTITUTE OF ENGINEERING & TECHNOLOGY**

(Approved by A.I.C.T.E., New Delhi & Affiliated to JNTUK, Kakinada)

**NAAC Accredited Institute**

An ISO 9001:2008, 14001:2004 & OHSAS 18001:2007 Certified Institute  
NH-5, Anakapalle, Visakhapatnam-531002, Andhra Pradesh

b. One who possesses many talents?

A). Versatile B). Nubile C). Exceptional D). Gifted

**V. 1. Write a newspaper report about an accident that took place on the main road in your town.-5M**

**2. Explain the childhood and early life of J.C.Bose.-3M**

**3. In questions given below out of four alternatives, choose the one which can be substituted for the given word/sentence.-2M**

a. One who eats everything

A). Omnivorous B). Omniscient C). Irascible D). Insolvent

b. The custom or practice of having more than one husband at same time

A). Polygyny B). Polyphony C). Polyandry D). Polychromic

### **UNIT- V**

**I.1.How does climate change affect human health?-5M**

**2. Explain the early life of Prafulla Chandra Ray.-3M**

**3. Fill the blank with suitable preposition.-2M**

a. Peter is playing tennis \_\_\_\_\_ Sunday.

b. What are you doing \_\_\_\_\_ the afternoon?

**II. 1. Write a short note on aeroallergens.-5M**



## **DADI INSTITUTE OF ENGINEERING & TECHNOLOGY**

(Approved by A.I.C.T.E., New Delhi & Affiliated to JNTUK, Kakinada)

**NAAC Accredited Institute**

An ISO 9001:2008, 14001:2004 & OHSAS 18001:2007 Certified Institute

NH-5, Anakapalle, Visakhapatnam-531002, Andhra Pradesh

**2. What are the contributions and achievements of Prafulla Chandra Ray?-3M**

**3. Fill the blank with suitable preposition.-2M**

A. The shops open \_\_\_\_\_ nine.

B. She has never seen the sea \_\_\_\_\_ winter.

**III. 1. How can we prevent climate change?-5M**

**2. Explain Assertiveness.-3M**

**3. Fill the blank with suitable preposition.-2M**

A. I have been waiting for you \_\_\_\_\_ seven o'clock.

B. I will have finished this essay \_\_\_\_\_ Friday.

**IV. 1. How are morality and excessive heat related?-5M**

**2. Write an essay on – “Climate Change”.-3M**

**3. Fill the blank with suitable preposition.-2M**

a. We are going to see my parents \_\_\_\_\_ the weekend.

b. In 1666, a great fire broke out \_\_\_\_\_ London.

**V. 1. What is public health surveillance and why is it important?-5M**

**2. Write an article on- “Air Pollution”.-3M**

**3. Fill the blank with suitable preposition.-2M**

a. My brother's birthday is \_\_\_\_\_ the 5th of November.

b. My birthday is \_\_\_\_\_ May.



# DADI INSTITUTE OF ENGINEERING & TECHNOLOGY

(Approved by A.I.C.T.E., New Delhi & Affiliated to JNTUK, Kakinada)

**NAAC Accredited Institute**

An ISO 9001:2008, 14001:2004 & OHSAS 18001:2007 Certified Institute  
NH-5, Anakapalle, Visakhapatnam-531002, Andhra Pradesh

## UNIT- VI

**I. 1. What does SMART mean in goal setting?-5M**

**2. Who is Paul Allen? Write the achievements of Allen with Gates.-3M**

**3. Fill the gap with the suitable verb.-2M**

A. One of my friends \_\_\_\_\_ gone to France. (has / have)

B. Each of the boys \_\_\_\_\_ given a present. (was / were)

**II.1. Why IBM approached Bill Gates? Explain the problems and prospects of their agreement.-5M**

**2. Who is Srinivasa Ramanujan?-3M**

**3. Fill the gap with the suitable verb.-2M**

A. Neither of the contestants \_\_\_\_\_ able to win a decisive victory. (was / were)

B. Oil and water \_\_\_\_\_ not mix. (do / does)

**III.1. Explain the family details of Bill Gates.-5M**

**2. Explain the education and research career of Srinivasa Ramanujan?-3M**

**3. Fill the gap with the suitable verb.-2M**

a. He and I \_\_\_\_\_ at Oxford together. ( was / were)

b. Slow and steady \_\_\_\_\_ the race. (win / wins)



## **DADI INSTITUTE OF ENGINEERING & TECHNOLOGY**

(Approved by A.I.C.T.E., New Delhi & Affiliated to JNTUK, Kakinada)

**NAAC Accredited Institute**

An ISO 9001:2008, 14001:2004 & OHSAS 18001:2007 Certified Institute  
NH-5, Anakapalle, Visakhapatnam-531002, Andhra Pradesh

**IV. 1. What are the advantages of team work?-5M**

**2. Explain the achievements of Ramanujan at Cambridge.-3M**

**3. Fill the gap with the suitable verb.-2M**

A. Neither Peter nor James \_\_\_\_\_ any right to the property. (has / have)

B. No prize or medal \_\_\_\_\_ given to the boy, though he stood first in the examination. (was / were)

**V. 1. Why did Bill Gates and Allen sue a case against the new owner of MITS?-5M**

**2. Write a report on- "Blood donation camp".-3M**

**3. Fill the gap with the suitable verb.-2M**

a. Either Mary or Alice ..... responsible for this. (is / are)

b. Neither the Minister nor his colleagues ..... given any explanation for this. (have / has)