

**I B.Tech Question Bank**

**Subject : Applied Chemistry**

**Branch & Semester: CSE-A & I/II**

**Faculty:**

**Dr Ch.Nageswara Rao,**

**Department: Humanities & Basic Sciences**

**Designation:**

**Associate professor**

---

**UNIT-1**

1. (a) Write the Suspension and Emulsion polymerisation? 6M  
(b) Explain the stereo specific polymers? 4M
2. (a) Write the differences between thermo plastics and thermosetting plastics. 4M  
(b) Explain the fabrication methods of Plastics? 6M
3. Write the preparation, properties and applications of the following plastics 10M  
i) Polyethene ii) Bakelite iii) Teflon and iv) BUNA-S
4. Explain the (a) Biodegradable polymers? 5M  
(b) Fibre Reinforced plastics? 5M
5. Explain the mechanism of (i) Addition polymerisation? 7M  
(ii) Condensation polymerisation? 3M

**UNIT - II**

1. (a) Define the Calorific Value, LCV and HCV of a fuel? 4M  
(b) Describe how the Calorific value of a solid fuel is determined using a bomb calorimeter? 6M
2. Explain the a) Proximate analysis of coal ? 5M  
b) Ultimate analysis of coal? 5M
3. (a) Write a note on (a) Octane Number and Cetane Number? 4M  
(b) Find HCV and LCV of a coal sample containing: 75% C; 10% H<sub>2</sub>; 8% O<sub>2</sub>; 5% N<sub>2</sub> and 2% S and remaining is ash. Assume latent heat of steam. 6M
4. Define the (a) Petrol Knocking and Diesel Knocking ? 4M  
(b) Refining of petroleum. 6M
5. (a) Write a brief note on Explosives? 4M  
(b) Explain the Natural gas, LPG and CNG? 6M

**UNIT- III**

1. Explain the (a) Standard hydrogen electrode and Calomel electrode. 7M  
(b) Electrochemical series? 3M
2. Define the (a) Single electrode potential and give its significance? 3M  
(b) Lithium cells? 7M
3. (a) Explain the galvanic cell? 5M  
(b) Define corrosion? Write the factors affecting the corrosion? 5M
4. Discuss the mechanism of corrosion? 10M
5. Explain the (a) Cathodic protection? 6M  
(b) Galvanization and Tinning? 4M

**I B.Tech Question Bank**

**Subject : Applied Chemistry**

**Branch & Semester: CSE-A & I/II**

**Faculty:**

**Dr Ch.Nageswara Rao,**

**Department: Humanities & Basic Sciences**

**Designation:**

**Associate professor**

---

**UNIT-IV**

1. Explain the (a) SEM and TEM for the preparation of Nano materials? 7M  
(b) Applications of Nanomaterials 3M
2. Write a detailed account on the (a) Types of superconductors. 6M  
(b) Engineering application of superconductors. 4M
3. Write a detailed account on the (a) Preparations, and properties of carbon nano tubes. 6M  
(b) Engineering application of carbon nano tubes 4M
4. (a) What is the green Chemistry? Write the principles of green chemistry? 6M  
(b) Write any two methods of synthesis of compounds by using green chemistry? 4M
5. Write the (a) Sol-gel method for the preparation of Nano materials? 5M  
(b) R<sub>4</sub>M<sub>4</sub> principles in green chemistry? 5M

**UNIT-V**

1. (a) Define the term semiconductor, give examples. And explain the conduction process in semi Conductors. 5M  
(b) What are stoichiometric and non- stoichiometric semiconductors? 5M
2. (a) Explain Controlled valency semiconductors. 6M  
(b) Explain the phenomenon of Doping. 4M
3. Name the four types of crystalline solids. 5M  
(b) What is BCC and FCC packing of metals? Give examples for BCC and FCC metals. 5M
4. (a) Explain magnetism and what are the magnetic materials? 4M  
(b) Discuss briefly regarding the Ferro and Ferri magnetic materials? 6M
5. (a) Discuss about the (a) Hall Effect and its applications? 6M  
(b) Engineering applications of insulators? 4M

**UNIT-VI**

1. Discuss about (a) Photovoltaic cells. 7M  
(b) Solar Cells. 3M
2. Discuss briefly about the hydro power and its sources, applications? 10M
3. Write note on geothermal energy and its applications? 10M
4. Write about (a) the types of cycles in OTEC plant?  
(b) the process of OTEC by a schematic diagram? 10M
5. Write a brief note on bio mass and its conversion into useful energy. 10M



# DADI INSTITUTE OF ENGINEERING & TECHNOLOGY

(Approved by A.I.C.T.E., New Delhi & Affiliated to JNTUK, Kakinada)

NAAC Accredited Institute

An ISO 9001:2008, ISO 14001:2004 & OHSAS 18001:2007 Certified Institute.

NH-5, Anakapalle – 531002, Visakhapatnam, A.P.

Phone: 08924-221111 / 221122/9963981111, www.diet.edu.in, E-mail: [info@diet.edu.in](mailto:info@diet.edu.in)

## ENGINEERING MECHANICS QUESTION BANK

Branch: CSE(A),(B)

Name of the faculty: **K.PADMAJA (CSE-A), B.USHA RANI (CSE-B)**

### UNIT – 1

1. a. List coulomb's laws of dry friction? [3M]  
b. State and prove Varignon's Theorem [4M]  
c. Differentiate between static friction and kinetic friction [3M]
2. a. Explain the term force and list its characteristics [5M]  
b. State and explain law of transmissibility of forces [5M]
3. a. Define cone of friction and explain it with a neat diagram? [4M]  
b. Define and explain  
i. angle of friction  
ii. angle of repose [6M]
4. a. Discuss about position vector of a given point? [4M]  
b. write a brief to find the resultant of parallel forces? [6M]
5. a Define  
i. Limiting Friction  
ii. Coefficient of Friction [2+2]  
b. Explain  
i. Moment of a force  
ii. Couple [3+3]
6. Forces  $P_1, P_2, P_3, P_4$  of magnitudes 10KN, 20KN, 25KN and 40 KN are concurrent in space and are directed through the points A(3,2,5), B(1,7,4), C(4,-2,4) and D(-2,4,-3) respectively. Determine the resultant of system of forces. Given the system of forces are concurrent at origin
7. a. What is friction and give the different types of friction? Explain in detail [6M]  
b. What do you mean by coplanar concurrent force system? Explain with suitable example [4M]

### UNIT – 2

1. a. What is converse law of triangle law of forces? [3M]  
b. What is converse law of polygon law of forces? [3M]  
c. Discuss free body diagrams with example [4M]
2. a. State and prove Lami's theorem? [6M]  
b. Discuss the graphical method to find the equilibrium of coplanar forces? [4M]
3. Five forces are acting on a point. The magnitude of the forces are 300N, 600N, 700N, 900N and P and their respective angles with the horizontal are  $0^\circ, 60^\circ, 135^\circ, 210^\circ$  and  $270^\circ$ . If the vertical components of all forces is -1000N. Find the

value of P. Also calculate the magnitude and direction of the resultant, assuming that the first force acts towards the point while all other remaining forces act away the point? [10M]

4. a. Two smooth spheres each of radius 100mm and weighing 100N, rest in a horizontal channel having vertical walls, the distance between which is 360mm. find the reactions at the points of contacts A, B, C and D show in fig. [7M]

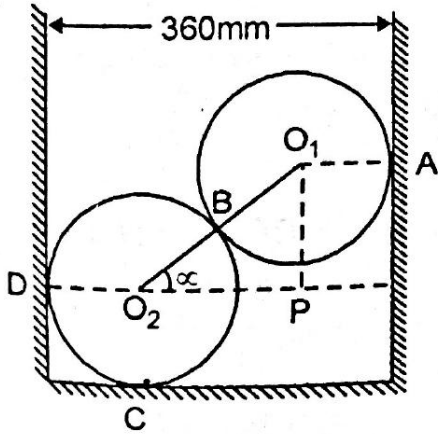

b. What are the equations of equilibrium of forces for coplanar system? List and discuss [3M]

5. A weight of W is suspended from a point B of a cable ABC. The ends of the cable are pulled by equal weights P overhanging small pulleys A and C. which are on the same level. Neglecting the radii of the pulleys. Determine the sag BD if  $l = 3m$ ,  $P = 80N$ ,  $W = 40N$ .

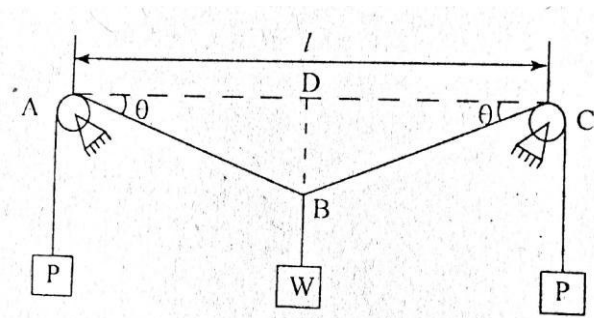

[10M]

6. The resultant of two forces, one of which is double the other is 260N. If the direction of the larger force is reversed and the other remains unaltered, the resultant reduces to 180N. Determine the magnitude of the forces and the angle between the forces [10M]

**UNIT – 3**

1. a. State and prove Pappus Theorem – I [6M]
- b. Where does the centroid of the following figures lie theoretically? [4M]
  - i. Triangle
  - ii. Rectangle
  - iii. Circle
  - iv. Rod
2. a. How do you find the centroid of a composite figure? Explain with a diagram [5M]
- b. State and prove Second theorem of Pappus [5M]
3. a. Determine the centroid of a triangle [7M]

- b. Define axis of symmetry and explain it with neat diagram [3M]
4. a. Determine the centroid of Semi Circle [5M]  
 b. Determine the centroid of a Sector [5M]
5. a. Determine the centroid of a parabolic spandrel [6M]  
 b. Determine the centroid of a rectangle [4M]
6. A semicircle is removed from the trapezoid as shown. Determine the centroid of the remaining area [10M]

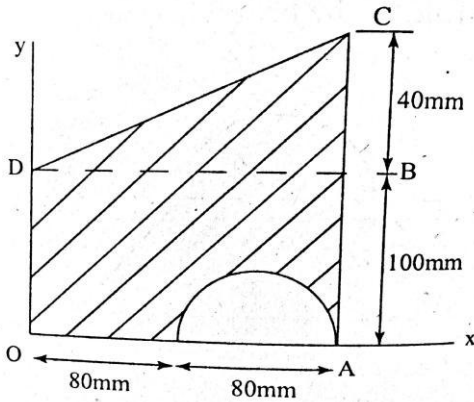

**UNIT – 4:**

**1.** Find the moment of inertia of T-section shown in fig. w.r.t centroid x and y axis

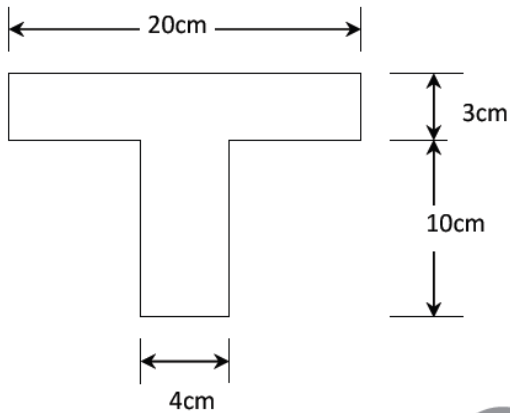

[10]

1. a. Express the mass moment of inertia of a thin plate in terms of its area moment of inertia [5]  
 b. Derive the transfer formula for product of inertia [5]
3. a. What is polar moment of inertia? [3]  
 b. Derive the Mass Moment of inertia of a rectangular plate [7]
4. a. Derive the moment of inertia of a triangle about the centroidal axis, x-x parallel to the base using parallel axis theorem [7]  
 b. What is radius of gyration? Explain it briefly [3]
5. a. Derive the moment of inertia of circle about its diametral axis [8]  
 b. What is mass moment of inertia? Explain in detail [2]
6. Derive the moment of inertia of a rectangle about the  
 a. Centroidal axis [5]  
 b. Base [5]
7. Derive the moment of inertia of a semicircle about the  
 a. Diametral axis [5]  
 b. Base [5]

**UNIT – 5:**

1. a. what is the relation between linear velocity and angular velocity [4]  
b. what are motion curves? Explain [6]
2. A ball is dropped from the top of a tower 30m high. At the same time a second ball is thrown upwards from the ground with an initial velocity of 15m/s. when and where do they cross each other and with what relative velocity? [10]
3. a. A motorist is travelling at 80kmph, when he observes a traffic light 200m ahead of him turns red. The traffic light is timed to stay red for 10sec. if the motorist wishes to pass the light without stopping, just as it turns green, determine (1) the required uniform deceleration of the motor, (2) the speed of the motor as it passes the light. [7]  
b. write about D'Alembert's principle [3]
4. a. what is the relation between linear acceleration and angular acceleration [3]  
b. write the conditions for skidding and overturning on a level road [7]
5. derive the conditions for skidding and overturning for banked roads [10]
6. a. discuss kinetics of rolling bodies [5]  
b. discuss with diagrams  
i. banking of roads [2]  
ii. super elevation [3]
7. a. A stone is vertically thrown upwards from the top of a building with a velocity of 20m/s. if it reaches the ground after 5 seconds, determine the height of the building [5]  
b. the maximum range of a projectile is 2000m. what should be the angle of elevation so as to obtain a range of 1400m if the initial velocity remains unchanged? [5]

**UNIT – 6:**

1. discuss the impulse momentum principle [10]
2. a. what is the work energy equation for translation [5]  
b. discuss about connected bodies [5]
3. a. discuss  
i. work  
ii. power [4+2]  
b. what is the work energy equation in the case of fixed axis rotation [4]
4. A flywheel weighing 50KN and having radius of gyration 1m loses its speed from 400RPM to 280RPM in 2 minutes. Calculate  
i. the retarding torque acting on it  
ii. change in its kinetic energy during the above period [10]
5. A 1500N block is in contact with a level plane, the coefficient of friction between two contact surfaces being 0.1. If the block is acted upon by a horizontal force of 300N, what time will elapse before the block reaches a velocity of 16m/sec starting from rest? If 300N force is then removed, how much longer will the block continue to move? Solve the problem using impulse momentum equation? [10]
6. A 20KN automobile is moving at a speed of 70kmph when the brakes are fully applied causing all four wheels to skid. Determine the time required to stop the automobile  
a. on concrete road for which coefficient of friction is 0.75  
b. on ice for which coefficient of friction is 0.08 [10]



**SUBJECT: MATHEMATICS-III**

**YEAR-I-II SEM**

**NAME OF THE FACULTY: S.GIRI BABU**

**BRANCH: CSE-A&B**

**UNIT-I**

1(a) Reduce A to canonical form and find its rank, if  $A = \begin{bmatrix} 1 & 2 & 3 & 0 \\ 2 & 4 & 3 & 2 \\ 3 & 2 & 1 & 3 \\ 6 & 8 & 7 & 5 \end{bmatrix}$

(b) Solve the system of equations  $20x + y - 2z = 17, 3x + 20y - z = -18, 2x - 3y + 20z = 25$  by Gauss Jacobi method.

2(a) Find the currents in the following circuit

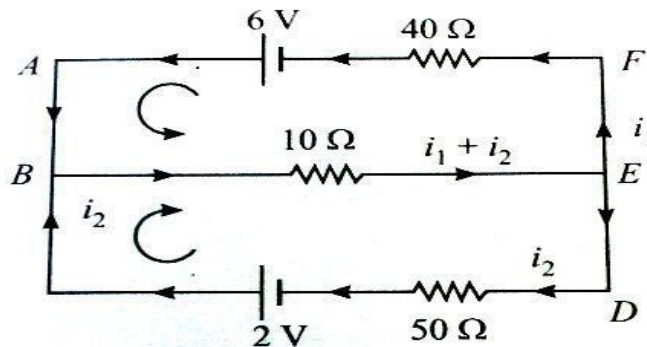

(b) Show that the system of equations is consistent  $2x - y - z = 2, x + 2y + z = 2, 4x - 7y - 5z = 2$  and solve

3(a) Solve the system of equations  $x + 10y + z = 6, 10x + y + z = 6, x + y + 10z = 6$  by Gauss Seidel method.

(b) Solve the system of equations  $10x - y - z = 13, x + 10y + z = 36, -x - y + 10z = 35$ .

4(a) Find the non singular matrices P and Q such that PAQ is in the normal form where

$$A = \begin{bmatrix} 3 & 2 & -1 & 5 \\ 5 & 1 & 4 & -2 \\ 1 & -4 & 11 & -19 \end{bmatrix}. \text{ Hence find its rank.}$$

(b) Find the values of 'a' and 'b' for which the equations  $x + y + z = 3$ ;  $x + 2y + 2z = 6$ ;

$x + ay + 3z = b$  have (i) No solution (ii) unique solution (iii) infinite no of solutions.

5(a) Determine the rank of a matrix  $\begin{bmatrix} -2 & -1 & -3 & -1 \\ 1 & 2 & 3 & -1 \\ 1 & 0 & 1 & -1 \\ 0 & 1 & 1 & -1 \end{bmatrix}$  by reduce into Normal form.

(b) Solve the equations  $3x + y + 2z = 3$ ,  $2x - 3y - z = -3$ ,  $x + 2y + z = 4$  using Gauss elimination method.

6 (a) Find for what values of 'a' the equations  $x + y + z = 1$ ,  $x + 2y + 4z = a$  and  $x + 4y + 10z = a^2$  have a solution.

(b) Find the currents in the following circuit

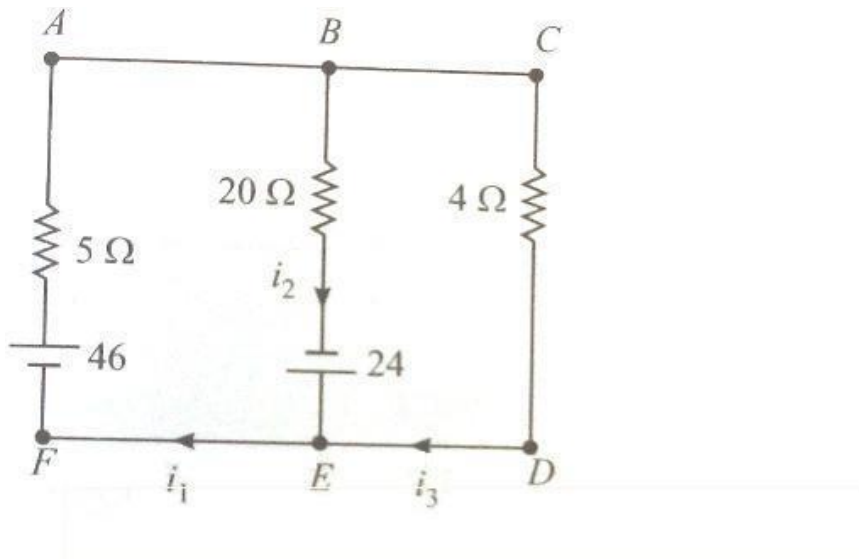

## UNIT-II



1(a) Find Eigen values and Eigen vectors of  $A = \begin{bmatrix} 6 & -2 & 2 \\ -2 & 3 & -1 \\ 2 & -1 & 3 \end{bmatrix}$

(b) Verify Cayley-Hamilton theorem of the matrix  $A = \begin{bmatrix} 1 & 2 & 3 \\ 2 & -1 & 3 \\ 1 & 1 & 2 \end{bmatrix}$

2(a) Verify Cayley-Hamilton theorem and find the inverse of the matrix  $A = \begin{bmatrix} 1 & 0 & 3 \\ 2 & 1 & -1 \\ 1 & -1 & 1 \end{bmatrix}$

(b) Reduce the quadratic form  $2x^2 + 2y^2 + 2z^2 - 2xy - 2yz - 2xz$  to canonical form by orthogonal transformation and hence find rank, index, signature and nature of the quadratic form.

3 (a) Verify Cayley-Hamilton theorem for the matrix  $A = \begin{bmatrix} 1 & 2 & -1 \\ 2 & 1 & -2 \\ 2 & -2 & 1 \end{bmatrix}$  and hence find  $A^4$ .

(b) Reduce the quadratic form  $3x_1^2 + 5x_2^2 + 3x_3^2 - 2x_1x_2 - 2x_2x_3 + 2x_1x_3$  to canonical form and hence state nature, rank, index and signature of the quadratic form.

4(a) Diagonalize the matrix  $\begin{bmatrix} 1 & 0 & -1 \\ 1 & 2 & 1 \\ 2 & 2 & 3 \end{bmatrix}$

(b) Determine the natural frequencies and normal modes of a vibrating system for which mass  $m = \begin{bmatrix} 1 & 0 \\ 0 & 2 \end{bmatrix}$  and stiffness  $k = \begin{bmatrix} 2 & 1 \\ 1 & 3 \end{bmatrix}$

4 (a) Find a non-singular matrix P such that A is diagonalizable, where  $\begin{bmatrix} 3 & -1 & 1 \\ -1 & 5 & -1 \\ 1 & -1 & 3 \end{bmatrix}$  Hence diagonalize A.

(b) Determine the natural frequencies and normal modes of vibrating system for which  $M = \begin{bmatrix} 2 & 0 \\ 0 & 4 \end{bmatrix}$  and stiffness  $K = \begin{bmatrix} -6 & -2 \\ -2 & 9 \end{bmatrix}$

6 (a) Find the natural frequencies and normal modes of a vibrating system  $mx'' + kx = 0$  for mass  $m = \begin{bmatrix} 2 & 0 \\ 0 & 1 \end{bmatrix}$  and stiffness  $k = \begin{bmatrix} 9 & -3 \\ -3 & 3 \end{bmatrix}$

(b) If A and B are n rowed square matrices and if A is invertible show that  $A^{-1}B$  and  $BA^{-1}$  have same Eigen Values.

## UNIT-III

1 (a) Trace the curve  $r^2 = a^2 \cos 2\theta$

(b) Evaluate  $\int_0^1 \int_{\sqrt{y}}^{2-y} xy dx dy$  by changing the order of integration.

2 (a) Evaluate  $\int_0^a \int_{\frac{x^2}{a}}^{2a-x} xy^2 dy dx$  by changing the order of integration.

(b) Trace the curve  $y^2(2a - x) = x^3$

3 (a) Trace the curve  $a^2 y^2 = x^2(a^2 - x^2)$

(b) Evaluate  $\int_0^\infty \int_0^\infty e^{-(x^2+y^2)} dx dy$  by changing in to polar coordinates and hence deduce

$$\int_0^\infty e^{-x^2} dx = \frac{\sqrt{\pi}}{2}$$

4(a) Evaluate  $\int_0^a \int_0^{\sqrt{a^2-x^2}} y(\sqrt{x^2+y^2}) dy dx$  by transforming to polar coordinates.

(b) Using double integration, find the volume of the sphere  $x^2 + y^2 + z^2 = a^2$ .

5(a) Trace the curve  $y = \frac{x^2+1}{x^2-1}$

(b) Evaluate  $\iint (x^2 + y^2) dx dy$ , in the +ve quadrant for which  $x + y \leq 1$ .

6 (a) Trace the curve  $r = a + b \cos \theta$ ,  $a > b$ .

(b) Evaluate  $\int_0^a \int_x^a (x^2 + y^2) dy dx$  by changing the order of integration.

## UNIT-IV

1(a) Show that  $\Gamma\left(\frac{1}{2}\right) = \sqrt{\pi}$

(b) Evaluate  $\int_0^1 x^4 \left(\log \frac{1}{x}\right)^3 dx$

2(a) Evaluate  $\int_0^\infty x^2 e^{-x^2} dx$ .

(b) Express  $\int_0^1 x^m (1-x^n)^p dx$  in terms of  $\Gamma$  functions and hence evaluate  $\int_0^1 x^5 (1-x^3)^{10} dx$

3(a) Evaluate  $\int_0^{\frac{\pi}{2}} \sin^5 \theta \cos^7 \theta d\theta$  by using  $\beta$ ,  $\Gamma$  functions.

(b) ) Express  $\int_0^4 \sqrt{x} (4-x)^{\frac{3}{2}} dx$ . in terms of  $\beta$  function.

4(a) Show that  $\beta(m, n) = \frac{\Gamma(m)\Gamma(n)}{\Gamma(m+n)}$  where  $m > 0, n > 0$

(b) Express  $\int_0^1 \frac{dx}{(1-x^3)^{1/3}}$ , in terms of  $\beta$  - function.

5(a) Evaluate  $\int_0^{\pi/2} \sin^4 \theta \cos^2 \theta d\theta$  by using  $\beta$  &  $\Gamma$  functions

(b) Express  $\int_0^1 \frac{x dx}{\sqrt{1+x^4}}$  in terms of  $\beta$  function

6(a) Evaluate  $\int_0^2 (8-x^3)^{-\frac{1}{3}} dx$  by using  $\beta$ ,  $\Gamma$  functions

(b) Show that  $\int_0^{\infty} \frac{x^{m-1}}{(a+bx)^{m+n}} dx = \frac{\beta(m, n)}{a^n b^m}$

## UNIT-V

1(a) Show that the vector field  $\vec{F} = (x^2 + xy^2)\vec{i} + (y^2 + x^2y)\vec{j}$  is conservative and find the scalar potential function.

(b) Show that  $\nabla(\nabla \cdot \vec{F}) = \nabla \times (\nabla \times \vec{F}) + \nabla^2 \vec{F}$

2(a) Find the angle between the surfaces  $ax^2 + y^2 + z^2 - xy = 1$  and conservative  $bx^2y + y^2z + z = 1$  at  $(1, 1, 0)$ .

(b) Show that  $\vec{F} = (y^2 - z^2 + 3yz - 2x)\vec{i} + (3xz + 2xy)\vec{j} + (3xy - 2xz + 2z)\vec{k}$  is both solenoidal and irrotational.

3(a) Show that the vector  $(x^2 - yz)\vec{i} + (y^2 - zx)\vec{j} + (z^2 - xy)\vec{k}$  is irrotational and find its scalar potential.

(b) Prove that  $\text{div}(\vec{F} \times \vec{G}) = \vec{G} \cdot \text{curl} \vec{F} - \vec{F} \cdot \text{curl} \vec{G}$

4(a) Find the directional derivative of  $\frac{1}{r}$  in the direction of  $\vec{r} = xi + yj + zk$  at  $(1, 1, 2)$

(b) Show that the vector  $(x^2 - yz)\vec{i} + (y^2 - zx)\vec{j} + (z^2 - xy)\vec{k}$  is irrotational and find its scalar potential.

5(a) Find the constants a, b such that the surfaces  $5x^2 - 2yz - 9x = 0$  and  $ax^2y + bz^3 = 4$  cut orthogonally at  $(1, -1, 2)$ .

(b) Find the directional derivative of  $\frac{1}{r}$  in the direction of  $\vec{r} = xi + yj + zk$  at  $(1, 1, 2)$

6(a) If  $f, g$  are scalar fields, show that  $\nabla f \times \nabla g$  is solenoidal

(b) Find constants  $a, b, c$  so that the vector  $\vec{A} = (x + 2y + az)\vec{i} + (bx - 3y - z)\vec{j} + (4x + cy + 2z)\vec{k}$  is irrotational also find  $\phi$  such that  $\vec{A} = \nabla \phi$ .

## UNIT-VI

1. State Greens theorem in plane and verify the theorem for  $\oint_C [(y - \sin x) dx + \cos x dy]$  where C

is the plane triangle formed by the lines  $y = 0, x = \frac{\pi}{2}$  and  $y = \frac{2}{\pi}x$ .

2. State Stoke's theorem and verify the theorem for  $\vec{F} = (x + y)\vec{i} + (y + z)\vec{j} - x\vec{k}$  and S is the surface of the plane  $2x + y + z = 2$ , which is in the first octant.

3. State Gauss divergence theorem in plane and verify the theorem for  $\vec{F} = 4xz\vec{i} - y^2\vec{j} + zy\vec{k}$  over the cube  $x = 0, x = 1, y = 0, y = 1, z = 0, z = 1$ .

4. (a) Find the total work done by a force  $\vec{F} = 2xy\vec{i} - 4z\vec{j} + 5x\vec{k}$  along the curve

$x = t^2, y = 2t + 1, z = t^3$  from the points  $t = 1, t = 2$ .

(b) Evaluate  $\oint_C (2x^2 - y^2) dx + (x^2 + y^2) dy$  by using Green's theorem where C is the boundary of the surface in the xy plane enclosed by x-axis and the semi-circle

5. (a) Find the work done in a moving particle along a straight line from  $(0,0,0)$  to  $(2,1,3)$  under the force  $F = 3x^2\vec{i} + (2xz - y)\vec{j} + z\vec{k}$ .

(b) Evaluate  $\iint_S \vec{A} \cdot \hat{n} dS$ , where  $\vec{A} = z\hat{i} + x\hat{j} - 3y^2z\hat{k}$  and S is the surface of the cylinder

$x^2 + y^2 = 16$  included in the first octant between  $z = 0$  and  $z = 5$

6.(a) Evaluate  $\oint_C \vec{F} \cdot d\vec{r}$  by using Stoke's theorem, where  $\vec{F} = y^2\hat{i} + x^2\hat{j} - (x + z)\hat{k}$  and C is the boundary of the triangle with vertices at  $(0,0,0), (1,0,0)$  and  $(1,1,0)$ .

(b) Use Gauss divergence theorem to evaluate  $\iint_S (xi + yj + z^2k) \cdot \hat{n} ds$  where S is the surface bounded by the cone  $x^2 + y^2 = z^2$  in the plane  $z = 4$ .

# DADI INSTITUTE OF ENGINEERING & TECHNOLOGY

(Approved by A.I.C.T.E., New Delhi & Affiliated to JNTU, Kakinada)



**NAAC Accredited Institute**

An ISO 9001:2008; ISO 14001:2004 & OHSAS 18001:2007 Certified Institution

NH-5, Anakapalle – 531002, Visakhapatnam, A.P.

Phone: 08924-221111 / 221122/9963981111, e-mail: [info@diet.edu.in](mailto:info@diet.edu.in)

---

## Question Bank

Name of the faculty: M.Lalitha

Branch: CSE-A&B; ECE

Year/Sem: I/II

Department: H & BS

Subject: Environmental studies

### Unit-1

1. a) Discuss the scope of environmental education? 5m  
b) What is the role of IT on environment and human health? 5m
2. Why is environmental studies considered as a multi – disciplinary subject? 10m
3. Discuss the causes and effects of global warming. 10m
4. a) Discuss the causes and effects of Acid rains. 5m  
b) Discuss the causes and effects of Ozone depletion. 5m
5. a) What are ecological pyramids? Write about different types of pyramids. 5m  
b) Give an account of energy flow in an ecosystem. 5m
6. Write about structure and function of ecosystem. 10
7. a) Write a short note on food web. 5m  
b) Discuss the phenomenon of ecological succession. 5m
8. Explain the structure and functioning of Forest or grassland ecosystem. 10
9. Describe the structure and functioning of a pond ecosystem. 10m

# DADI INSTITUTE OF ENGINEERING & TECHNOLOGY

(Approved by A.I.C.T.E., New Delhi & Affiliated to JNTU, Kakinada)



**NAAC Accredited Institute**

An ISO 9001:2008; ISO 14001:2004 & OHSAS 18001:2007 Certified Institution

NH-5, Anakapalle – 531002, Visakhapatnam, A.P.

Phone: 08924-221111 / 221122/9963981111, e-mail: [info@diet.edu.in](mailto:info@diet.edu.in)

## Unit-2

1. What are renewable and non-renewable energy resources? Give examples. 10m
2. What are the major causes and consequences of deforestation? 10m
3. a) Write about crises and conflict over water. 5m  
b) Write a short note on Soil erosion. 5m
4. What is mining? What are the impacts of mining on environment? 10m
5. a) What is the role of an individual in conservation of natural resources? 5m  
b) Describe few modern agricultural methods and their consequences. 5m

## Unit-3

1. a) Define biodiversity. Write about threats of biodiversity. 5m  
b) What are the three levels of biodiversity? 5m
2. What are the hot spots of biodiversity? 10m
3. What is meant by in situ and ex-situ conservation of biodiversity? Give examples. 10m
4. a) What are the different values of biodiversity? 5m  
b) Write about Endemic and Endangered Species. 10m

## Unit-4

1. a) Mention briefly about the various types of pollution. 5m  
b) Briefly describe sources, effects and control of noise pollution. 5m
2. Discuss adverse effects and control of water pollution. 10m

# DADI INSTITUTE OF ENGINEERING & TECHNOLOGY

(Approved by A.I.C.T.E., New Delhi & Affiliated to JNTU, Kakinada)



**NAAC Accredited Institute**

An ISO 9001:2008; ISO 14001:2004 & OHSAS 18001:2007 Certified Institution

NH-5, Anakapalle – 531002, Visakhapatnam, A.P.

Phone: 08924-221111 / 221122/9963981111, e-mail: [info@diet.edu.in](mailto:info@diet.edu.in)

3. Briefly describe sources, effects and control of various Air pollutants. 10m
4. What are the various types of solid waste and methods of safe disposal of solid waste?  
10m
5. a) Role of an individual in the prevention of environmental pollution? 5m  
b) Write a note on Bhopal Gas Tragedy. 5m

## Unit -5

1. a) What do you understand by environmental ethics? 5m  
b) Discuss the salient features of Wild life protection Act. 5m
2. a) Discuss the salient features of Forest Conservation Act. 5m  
b) What are the major limitations to successful implementation of all environmental legislation? 5m
3. What is rain water harvesting? What are the purposes served by it? 10m
4. a) What are the different methods to propagate environmental awareness in society?  
5m  
b) Write a note on Water act. 5m

## Unit -6

1. Write about EIA, its significance at various stages. 10m
2. a) Explain about environmental audit? 5m  
b) Discuss about environmental management plan. 5m
3. a) Discuss the concept of ecotourism, its principles and merits. 5m  
b) Write a short note on EIS. 5m



## ENGLISH- II QUESTION BANK- I B. TECH (CSE- A)

### Unit- I

- 1) **A.** Why does the author say that the Know how produced by Science and technology is an unfinished sentence?  
**B.** What is hovercraft?  
**C.** Give synonyms for the following:
  - i.** Strengthen
  - ii.** Resource
- 2) **A.** Explain Schumacher views on education?  
**B.** What was the objective of the SLV project?  
**C.** Give the synonyms of the following:
  - i.** Precipitate
  - ii.** Antecedent
- 3) **A.** What are the arguments which the author put forward to show that education is necessary?  
**B.** Who helped Kalam design the guidance systems for Agni Missile?  
**C.** Give synonyms for following:
  - i.** Apprehension
  - ii.** Brink
- 4) **A.** What should be done to overcome the problems of modern life?  
**B.** Why Abdul Kalam is called the Missile Man of India?  
**C.** Give Antonyms for the following words:
  - i.** Decline
  - ii.** Civilized
- 5) **A.** Write a letter to the editor of a leading newspaper on the problem of eve - teasing in your city.  
**B.** Explain the work Kalam did at DRDO.  
**C.** Give Antonyms for the following words:
  - i.** Inferior
  - ii.** Conceal
- 6) **A.** How is positive attitude helpful for the students?  
**B.** Name a few awards that Kalam won.  
**C.** Give antonyms for the following words:
  - i.** Culminate
  - ii.** Persuade





**UNIT- II**

- 1) **A.** Describe any modern invention with its positive and negative effects on the society.  
**B.** At what age did Raman join the graduation class? Can you remember an interesting anecdote concerning his English teacher?  
**C.** Write the superlative adjectives for the following words:
  - i.** Beautiful
  - ii.** Sweet
- 2) **A.** Who is responsible for the destructive use of scientific inventions- Science or people?  
**B.** What were some of the changes that Raman had initiated at the Indian Institute of Science?  
**C.** Write the superlative adjectives for the following words:
  - i.** Tall
  - ii.** Bright
- 3) **A.** What according to the author is the first reaction of a layman to the bomb on Hiroshima?  
**B.** Where did Raman do his M. A. from? What was his subject?  
**C.** Write superlative adjectives for the following words:
  - i.** Clever
  - ii.** Hard
- 4) **A.** What are views of author on science and its repercussions?  
**B.** Why did Raman resign from his job after 10 year of service? Why did he take a cut in his salary?  
**C.** Fill in the blanks with appropriate words:
  - i.** SLV stands for
  - ii.** Kalam's first school was
- 5) **A.** You are Mr. Deepak, the librarian of KVAFA. Write an email to Rana book depot, Hyderabad requesting them to cancel your order for English literary books and Children's story book. Give reasons for cancellation of the order.  
**B.** Explain the Raman Effect.  
**C.** Write synonyms for the following words:
  - i.** Mooting
  - ii.** Distinguished
- 6) **A.** Explain the importance of Self-Management.  
**B.** Describe the work that got Raman a Noble Prize.  
**C.** Write the adjective form for the following words:
  - i.** Hunger
  - ii.** Health



**Unit- III**

- 1) **A.** What is Cultural Shock? Explain.  
**B.** What were the objectives Bhabha wanted to fulfill with the nuclear Programme?  
**C.** Fill in the blank with an appropriate form of the verb given in brackets:
  - i. The deaf and the blind --- (find) it was very difficult to acquire the amenities of conversation.
  - ii. She --- (like) coffee compared to tea.
- 2) **A.** How does the author define 'culture shock'? What are the symptoms according to him?  
**B.** What was the most devastating event during the World War II?  
**C.** Fill in each blank with an appropriate form of the verb given in brackets:
  - i. When he --- (come) home I was taking shower.
  - ii. He --- (finish) homework before I called him.
- 3) **A.** Write the four stages of cultural shock.  
**B.** Note contributions of Ernest Rutherford.  
**C.** Fill in the blank with an appropriate form of the verb given in brackets:
  - i. The train --- (have left) before I reached the station.
  - ii. She --- (lost) the key just now.
- 4) **A.** Prepare a 5 minutes speech expressing your views on the following topic: ***Betting in sports.***  
**B.** Who was Dirac? What was his major contribution?  
**C.** Fill in the blank with an appropriate form of the verb given in brackets:
  - i. She --- (play) football every day.
  - ii. She --- (go) to church every Sunday.
- 5) **A.** Explain Non - Verbal Communication.  
**B.** What were Bhabha's efforts to set up research institute in India?  
**C.** Fill in the blank with an appropriate form of the verb given in brackets:
  - i. She --- (see) Delhi many times.
  - ii. She --- (have work) a lawyer since 2000.
- 6) **A.** What is Body Language?  
**B.** What is the message of Bhabha to the youth?



C. Fill in the blank with an appropriate form of the verb given in brackets:

- i. Summer----- (come) after winter.
- ii. She----- (meet) the principal yesterday.

### UNIT- IV

- 1) 

**A.** What seems to have been the original purpose of the lottery? What do people believe about it?

**B.** What was Bose's attitude towards education as he grew up?

**C.** In questions given below out of four alternatives, choose the one which can be substituted for the given word/sentence:

  - i. That which cannot be corrected  
A. Unintelligible B. Indelible C. Illegible D. Incurable
  - ii. The study of ancient societies  
A. Anthropology B. Archaeology C. History D. Ethnology
- 2) 

**A.** Is it important that the original paraphernalia for the lottery had been lost? What do you suppose the original ceremony was like? Why have some of the villages given up this practice? Why hasn't this one?

**B.** Why did Bose shift his interest? What were his contributions to the two fields he worked in?

**C.** In questions given below out of four alternatives, choose the one which can be substituted for the given word/sentence:

  - i. A person of good understanding knowledge and reasoning power  
A. Expert B. Intellectual C. Snob D. Literate
  - ii. A person who insists on something  
A. Disciplinarian B. Stickler C. Instantaneous D. Boaster
- 3) 

**A.** Is the lottery a collective act of murder? Is it morally justified? Is tradition sufficient justification for such actions? How would you respond to cultures that are different from ours that perform "strange" rituals?

**B.** Give an account of Bose's experiments relating to plant responses.

C. In questions given below out of four alternatives, choose the one which can be substituted for the given word/sentence:

- i. State in which the few govern the many  
A. Monarchy B. Oligarchy C. Plutocracy D. Autocracy
- ii. A style in which a writer makes a display of his knowledge  
A. Pedantic B. Verbose C. Pompous D. Ornate

4) A. Write an essay on- “Global Warming”

B. Write the views of the author on J.C. Bose.

C. In questions given below out of four alternatives, choose the one which can be substituted for the given word/sentence:

- i. A person who knows many foreign languages  
A. Linguist B. Grammarian C. Polyglot D. Bilingual
- ii. One who possesses many talents  
A. Versatile B. Nubile C. Exceptional D. Gifted

5) A. Write a newspaper report about an accident that took place on the main road in your town.

B. Explain the childhood and early life of J.C. Bose.

C. In questions given below out of four alternatives, choose the one which can be substituted for the given word/sentence:

- i. One who eats everything  
A. Omnivorous B. Omniscient C. Irascible D. Insolvent
- ii. The custom or practice of having more than one husband at same time  
A. Polygyny B. Polyphony C. Polyandry D. Polychromic

### UNIT- V

1) A. How does climate change affect human health?

B. Explain the early life of Prafulla Chandra Ray.

C. Fill the blank with suitable preposition.

- i. Peter is playing tennis \_\_\_\_\_ Sunday.
- ii. What are you doing \_\_\_\_\_ the afternoon?



- 2) **A.** Write a short note on aeroallergens.  
**B.** What are the contributions and achievements of Prafulla Chandra Ray?  
**C.** Fill the blank with suitable preposition.
- i.** The shops open \_\_\_\_\_ nine.
  - ii.** She has never seen the sea \_\_\_\_\_ winter.
- 3) **A.** How can we prevent climate change?  
**B.** Explain Assertiveness.  
**C.** Fill the blank with suitable preposition.
- i.** I have been waiting for you \_\_\_\_\_ seven o'clock.
  - ii.** I will have finished this essay \_\_\_\_\_ Friday.
- 4) **A.** How are morality and excessive heat related?  
**B.** Write an essay on – “Climate Change”.  
**C.** Fill the blank with suitable preposition.
- i.** We are going to see my parents \_\_\_\_\_ the weekend.
  - ii.** In 1666, a great fire broke out \_\_\_\_\_ London.
- 5) **A.** What is public health surveillance and why is it important?  
**B.** Write an article on- “Air Pollution”.  
**C.** Fill the blank with suitable preposition.
- i.** My brother's birthday is \_\_\_\_\_ the 5th of November.
  - ii.** My birthday is \_\_\_\_\_ May.

## UNIT- VI

- 1) **A.** What does SMART mean in goal setting?  
**B.** Who is Paul Allen? Write the achievements of Allen with Gates.  
**C.** Fill the gap with the suitable verb.
- i.** One of my friends \_\_\_\_\_ gone to France. (has / have)
  - ii.** Each of the boys \_\_\_\_\_ given a present. (was / were)
- 2) **A.** Why IBM approached Bill Gates? Explain the problems and prospects of their agreement.



**DADI INSTITUTE OF ENGINEERING & TECHNOLOGY**

(Approved by A.I.C.T.E., New Delhi & Affiliated to JNTUK, Kakinada)

**NAAC Accredited Institute**

An ISO 9001:2008, 14001:2004 & OHSAS 18001:2007 Certified Institute  
NH-5, Anakapalle, Visakhapatnam-531002, Andhra Pradesh

---

- B.** Who is Srinivasa Ramanujan?
- C.** Fill the gap with the suitable verb.
- i.** Neither of the contestants \_\_\_\_\_ able to win a decisive victory. (was / were)
  - ii.** Oil and water \_\_\_\_\_ not mix. (do / does)
- 3) A.** Explain the family details of Bill Gates.
- B.** Explain the education and research career of Srinivasa Ramanujan?
- C.** Fill the gap with the suitable verb.
- i.** He and I \_\_\_\_\_ at Oxford together. ( was / were)
  - ii.** Slow and steady \_\_\_\_\_ the race. (win / wins)
- 4) A.** What are the advantages of team work?
- B.** Explain the achievements of Ramanujan at Cambridge.
- C.** Fill the gap with the suitable verb.
- i.** Neither Peter nor James \_\_\_\_\_ any right to the property. (has / have)
  - ii.** No prize or medal \_\_\_\_\_ given to the boy, though he stood first in the examination. (was / were)
- 5) A.** Why did Bill Gates and Allen sue a case against the new owner of MITS?
- B.** Write a report on- “Blood donation camp”.
- C.** Fill the gap with the suitable verb.
- i.** Either Mary or Alice ..... responsible for this. (is / are)
  - ii.** Neither the Minister nor his colleagues .....given any explanation for this. (have / has)